

# How-To Instructions

The workflows in this menu are exercises from the training manual that can be downloaded together with the F3 Demo training data set for self-training. For more information, please see [this page](#) on the TerraNubis website.

*This is not the Training Manual, if you want to see the Training Manual, go to [this page](#).*

Here is a list of short keys you can use in OpendTect (to pop up this list in OpendTect either press Shift+? or go to Help>Keyboard shortcuts):

View Mode		
Pan		Middle Click+Drag
Rotate		Shift + Middle Click + Drag
Zoom in/out		Scroll Wheel Ctrl + Middle Click + Drag

Position Mode		
Activate element		Left Click
De-activate element		Left Click outside active element
<b>Draggers – applied to Active Inline, Crossline, Z-slice or Random Line</b>		
Browse/Resize Volume perpendicular-to-plane		Left Click + Drag in Active Volume
Resize		Left Click + Drag (green) Anchors
Rotate (if possible)		Ctrl + Left Click + Drag
Move	perpendicular-to-plane	Left Click + Drag
	parallel-to-plane	Shift + Left Click + Drag

Basemap		
Add	Inline	i
	Crossline	c
	Random line	r

Main Short keys		
Show all Shortkeys		Shift + ?
Save selected object		Ctrl + s
Save as selected object		Shift + Ctrl + s
Undo /Redo		Ctrl + z / Ctrl + y
Toggle / Print 3D graphics stats		g / G
Pop up Command Controller		Ctrl + r
Toggle between "in full" / "at section" selected item display		v
inline/crossline/z-slice	Forward	x
	Backward	z

  

Interpretation Mode		
Pick seed		Left Click
Remove seed/pick		Ctrl + Left Click on seed/pick
Activate Polygon Selection		y
Multi Selection		y + Ctrl + Left Click
Move Single Selection		Left Click + Drag
Fault stick	New	Shift + Left Click
	Finish	Double Left Click
	Select (to edit)	Ctrl + Left Click on existing faultstick (outside seeds) Left Click on existing seed

Horizon Tracking		
Tracking menu		Ctrl + Right Click
Autotrack		k
Retrack		Ctrl + k
Lock / Unlock		l / u
Clear Selection		a
Delete Selection		d



---

# Table of Contents

---

<b>How-To Instructions</b> .....	<b>1</b>
Table of Contents .....	2
1.2.2a Survey Setup & Load SEG-Y .....	4
2.1.1b Set up Survey using PetrelDirect .....	12
1.2.3a Horizon .....	14
1.2.4a Well Data .....	16
1.4.4a Stacking Velocities .....	21
2.1.1c Import data from Petrel using PetrelDirect .....	23
1.3.1a Display An Inline .....	27
1.3.1b Pre-load Data .....	28
1.3.2a Position, Zoom, Pan, Rotate .....	29
1.3.3a Random Line .....	33
1.3.3b Random Line Through Wells .....	35
2.1.2a Basemap .....	36
2.1.3a PDF3D .....	38
2.3.1a Steering Cube .....	39
2.3.1d Dip-steered Median Filter .....	42
2.3.1f Dip-steered Diffusion Filter .....	45
2.3.1g Dip-steered Fault Enhancement Filter .....	49
2.3.3a Ridge Enhancement Filter .....	55
2.3.4a Spectral Blueing .....	58
2.3.5a Optical Stacking .....	64
2.3.5b Seismic Feature Enhancement .....	67
2.3.5c Fluid Contact Finder .....	71
1.4.1a Well Tie .....	75
1.4.2a 3D Auto-track .....	81
1.4.2b Tracking In 2D Viewer .....	90
1.4.3a Fault Planes .....	95
1.4.3b Fault Sticks .....	98
2.1.4a Thalweg Tracker .....	103
2.3.1h Unconformity Tracker .....	107
2.4.3a Well Correlation Panel .....	110
1.4.4b Grid Stacking Velocities .....	115
1.4.4c TD Conversion On-the-fly .....	119
1.4.4d TD Volume Conversion In Batch .....	122
1.5.1a Bright Spot .....	125
1.5.2a Spectral Decomposition .....	136
2.3.1b Dip & Azimuth .....	142
2.3.1c Dip-steered Similarity .....	144
2.3.1e Mathematics .....	148
2.3.1h Unconformity Tracker .....	150
2.3.2a Thinned Fault Likelihood .....	153
2.3.2b Volume Curvature And Others .....	155
2.4.2g Stratigraphic Attributes .....	160

---

1.5.3a Attributes - Attributes .....	164
1.5.3b Attributes - Wells .....	173
2.3.2c Bodies .....	176
2.3.2d Planes .....	180
2.3.6a Waveform Segmentation - Quick UVQ .....	184
2.3.6b Waveform Segmentation - Standard UVQ .....	187
2.3.6c ChimneyCube .....	193
2.4.1a Data-driven HorizonCube .....	200
2.4.1b 3D Bodies From HorizonCube .....	215
2.4.1c Truncate HorizonCube .....	220
2.4.1d Horizons From HorizonCube .....	223
2.4.2a Stratal Terminations .....	225
2.4.2b Stacking Patterns .....	227
2.4.2c Wheeler Scene .....	230
2.4.2d Systems Tracts .....	235
2.4.2e Statistical (Thickness) Curves .....	242
2.4.2f Stratigraphic Surfaces .....	245
2.4.2g Stratigraphic Attributes .....	251
2.4.2h Stratal Slicing .....	255
2.5.1a Coloured Inversion .....	260
2.5.2a Extracting Horizontal Variograms .....	266
2.5.2b Extracting Vertical Variograms .....	269
2.5.3a Neural Network Prediction .....	271
2.6.1 Well workflows .....	279
2.6.1a Log-Log Density .....	280
2.6.1b Log-Log Porosity .....	285
2.6.2 Lithology Classification .....	290
2.6.3 Seismic Bodies - Supervised 3D .....	297
2.6.4 Seismic Unet 3D Fault Predictor .....	303
2.6.5 3D Seismic and Wells RockProperty Prediction .....	307
2.6.6 Seismic Image to Image - Fault Prediction .....	312
2.6.7 Seismic Image Regression (Unet) - Fill Seismic Traces .....	319
<b>Glossary</b> .....	<b>331</b>
<b>Index</b> .....	<b>341</b>

---

## 1.2.2a Survey Setup & Load SEG-Y

Required licenses: OpendTect.

### Exercise objective:

Set up a new OpendTect survey and load 3D seismic data from SEG-Y using the SEG-Y scan wizard.

### Workflow:

1. **Go to** Survey > Select/Setup...

or **click** on the Survey Setup icon .

2. **Click** on the New Survey icon .

When starting OpendTect for the first time, you arrive directly in the Survey Setup & Selection window.

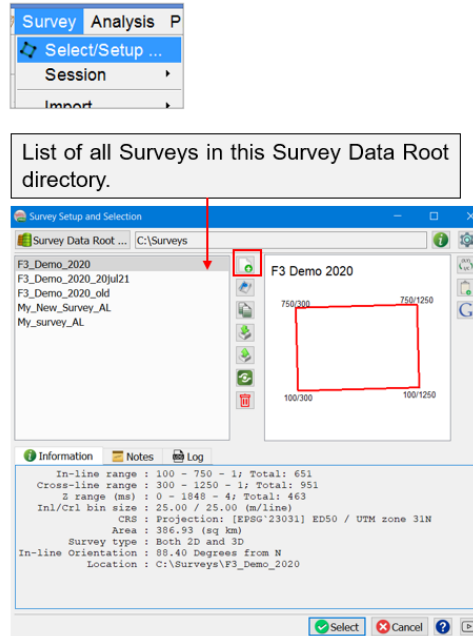

### Workflow cont'd:

3. **Specify** a Survey name and

(a) **select** Scan SEG-Y file(s),

(b) **set** Time for Z Domain,

(c) **Press** Next.

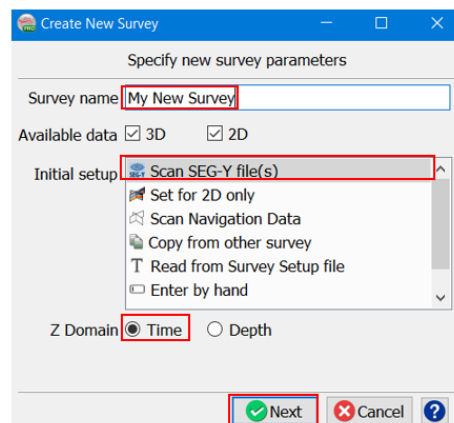

OpendTect display scenes are in Time or Depth. Transformation is done on-the-fly using a given velocity model. In the Survey Setup you choose the primary Z Domain. In the case of depth survey, Z Domain should be *Depth*.

**Workflow cont'd:**

4. Go to the Rawdata directory of F3 Demo and **Select** the Input SEG-Y file: \Raw data\Seismic\_data.sgy.

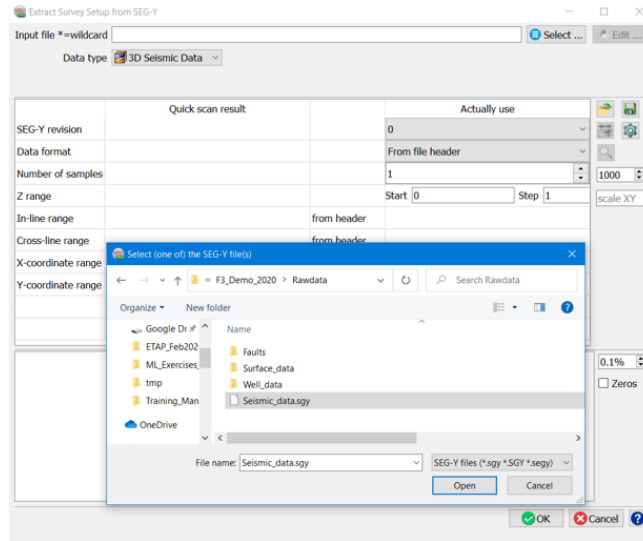

**Workflow cont'd:**



5. The import wizard makes a quick scan of the SEG-Y volume and automatically fills-in relevant parameters for survey set-up and import.

If needed, the parameters required for SEG-Y import (under the *Actually Use* column) can be changed manually.

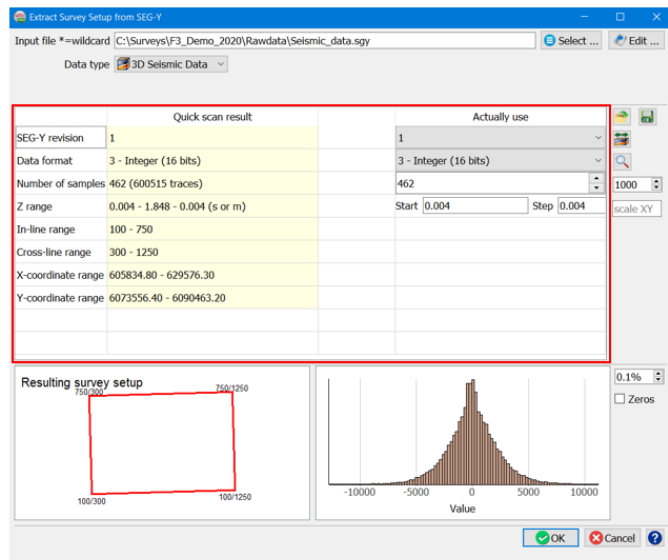
The bottom part shows the extracted geometry of the survey and the histogram of seismic amplitudes from the quick scan of the input SEG-Y volume.



**Workflow cont'd:**

- Optionally, **click** on the  icon to scan the entire input SEG-Y file.
- Click** on the  icon to examine in detail, first '1000' traces (changeable) of the file.

**Edit** option can be used if the SEG-Y file needs to be modified. You can update binary headers and trace headers using mathematical formulæ and information from other headers.

Scanning the entire SEG-Y file is useful when the survey geometry extracted from the quick scan looks doubtful.

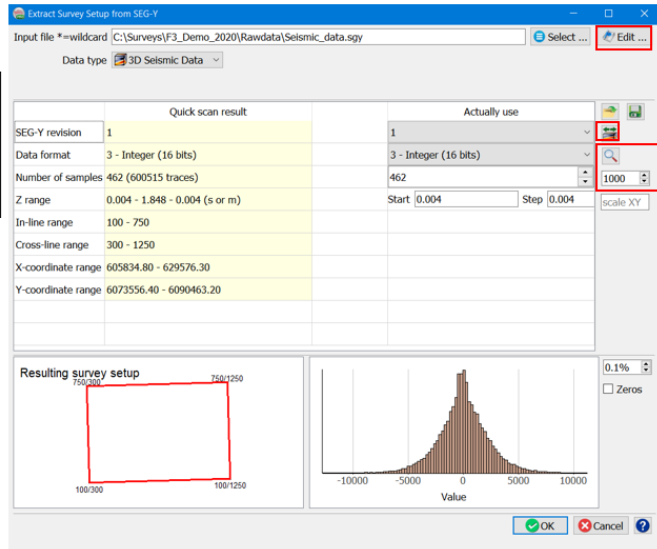

**Workflow cont'd:**

- Examiner window: **Use** this to find out what is inside the file.
- Check** the Inline, Crossline and X/Y coordinates : **find** the corresponding byte and **observe** the associated plot.
- Optionally, **check** Seismic viewer and histogram windows.

Trace header name + byte position.

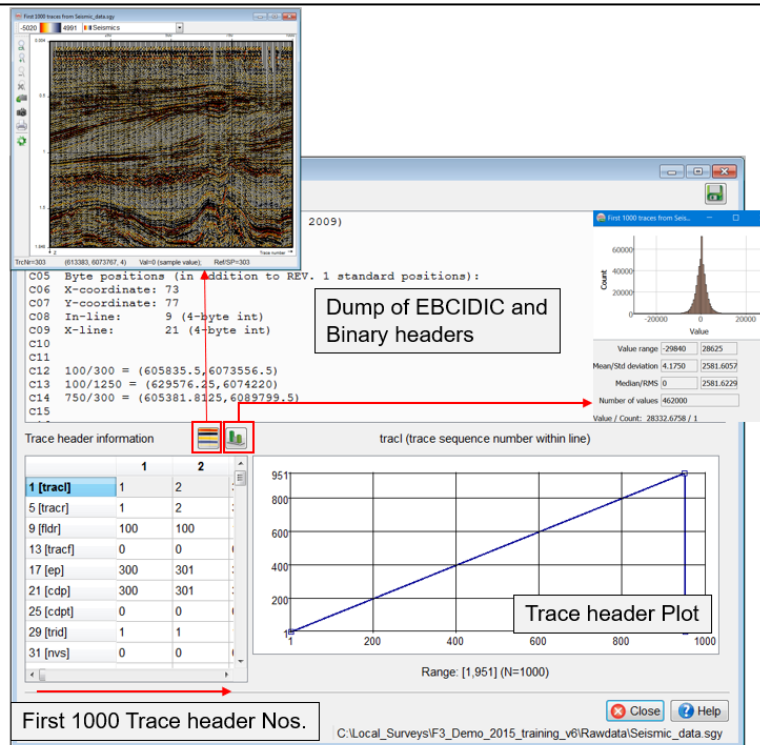

**Workflow cont'd:**

11. **Click** on OK. Optionally, **click** on the  icon to save the import set-up parameters.

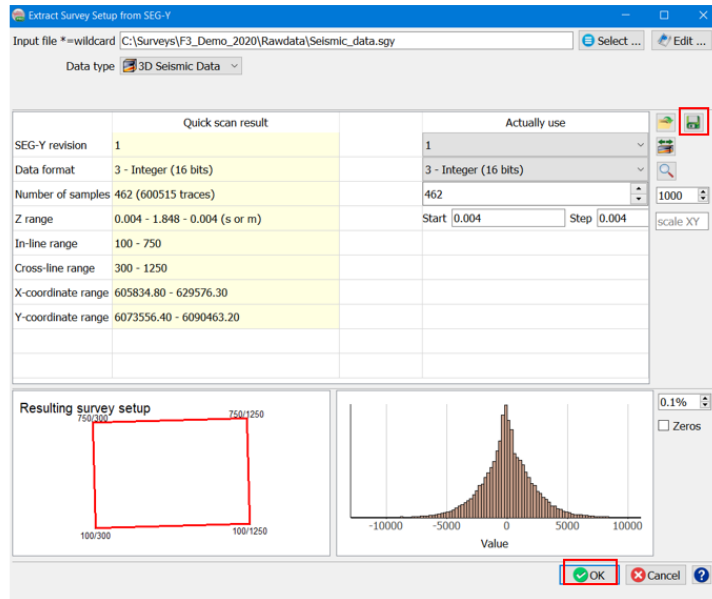

**Workflow cont'd:**

12. Survey definition is set now. **Click** on OK to proceed further.

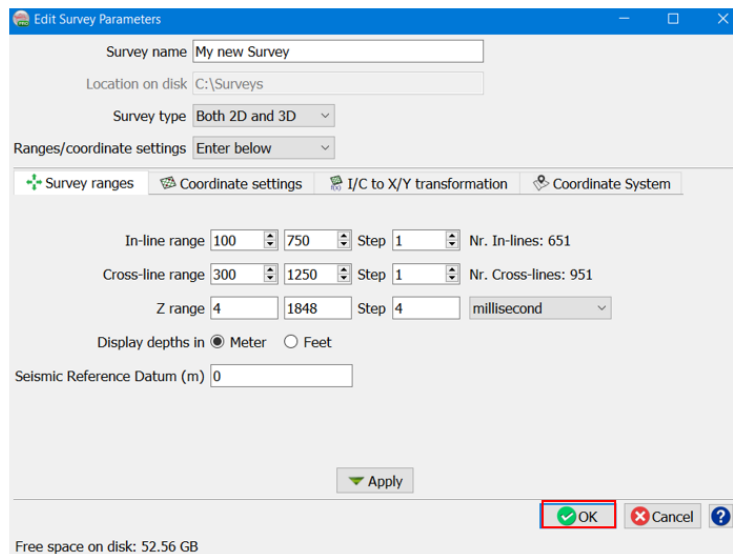

**Workflow cont'd:**

- 13. **Go** inside the newly created survey by either **double-clicking** on it or **clicking** on Select.
- 14. **Press** Yes when asked to import the SEG-Y file used to set-up the survey.

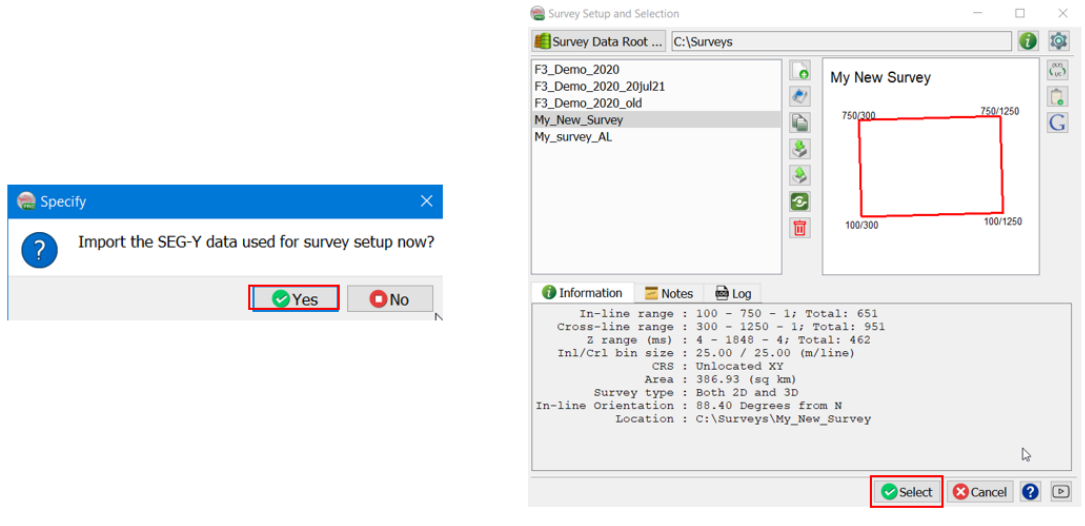

**Workflow cont'd:**

- 15. **Keep** the default Yes (import) toggled on, in front of Copy data. Optionally, it is possible to make a link to the input SEG-Y file in OpendTect.
- 16. **Specify** an Output Cube name (by default name of the input file is copied here).
- 17. **Press** Import.

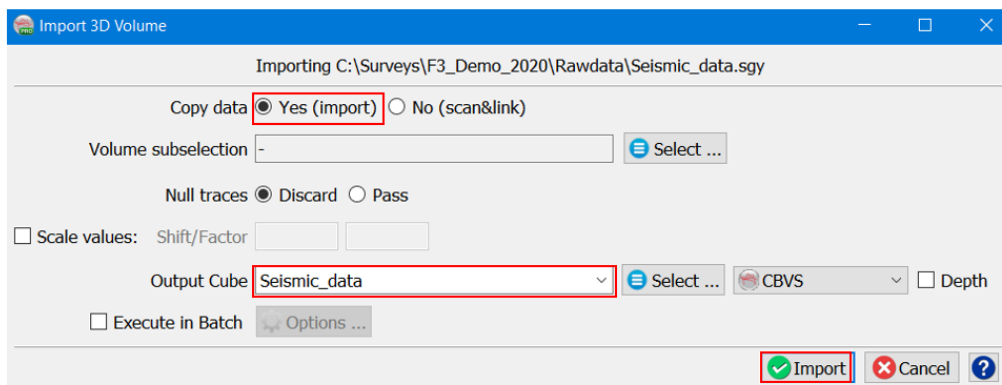



**Workflow cont'd:**

18. Once the import is finished, **press** OK on the notification window. Next, OpendTect will automatically open the option to change the Z-scaling of the newly created survey. **Move** the slider to set an appropriate Z scaling factor and **press** OK.

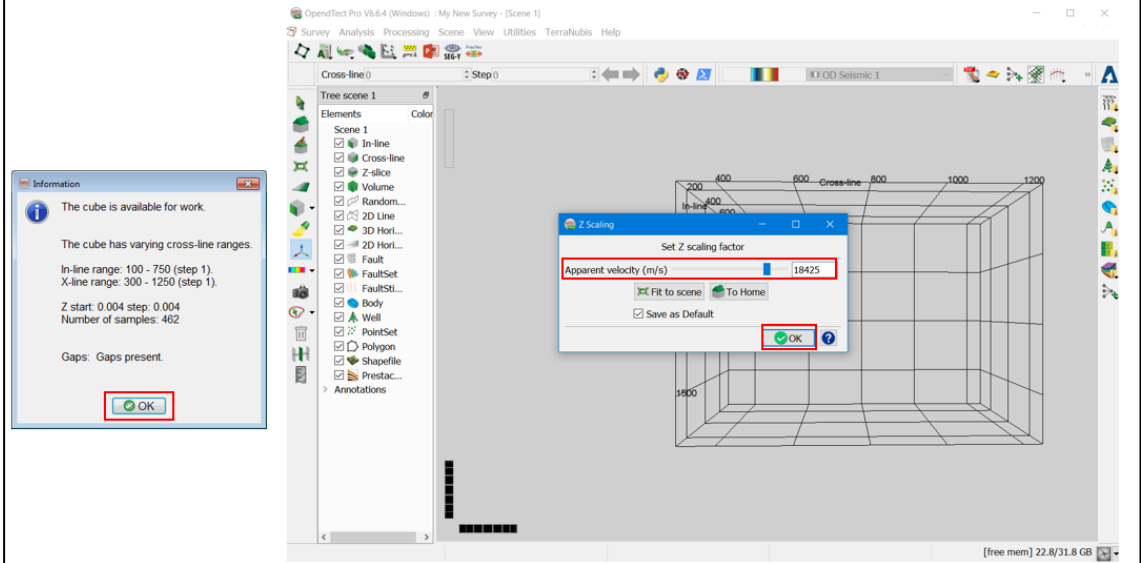

**Workflow cont'd:**

19. **Check** in the seismic manager the newly imported cube; Survey > Manage > Seismic > 3D.

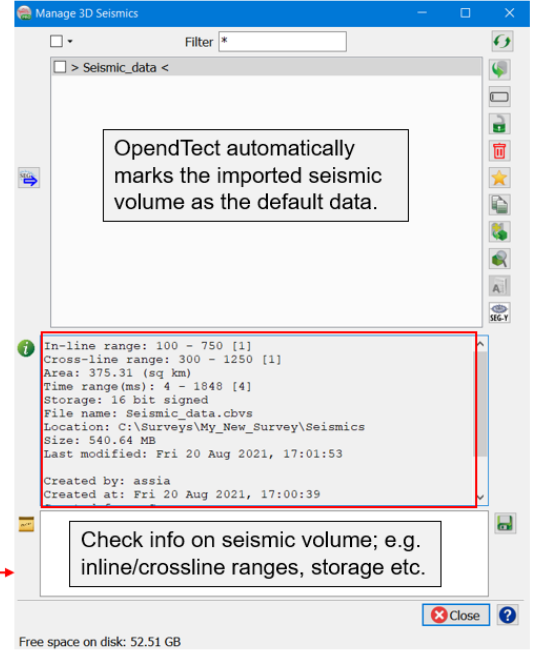
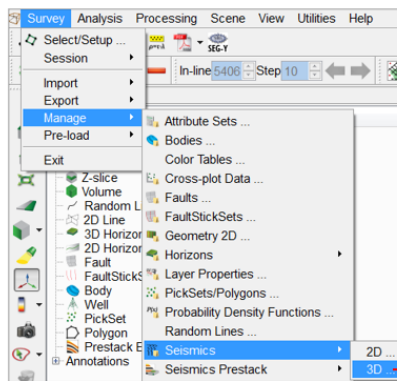

**Workflow cont'd:**

**Tips:**

- Changing the default Z-scale setting manually at any time
- Saving color settings with the loaded data set
- Manually making a seismic cube the default data set

**Changing the Z-scale at any time:**

1. Add an inline:
  - **Right-click** in the tree on Inline > Add and Select Data.
  - **Left-click** on the selected seismic data or **press** OK in the window that pops-up after step 1.
2. **Go to** View > Z-scale.
3. **Use** the slider to change Z. **Toggle on** Save as default and **press** OK.

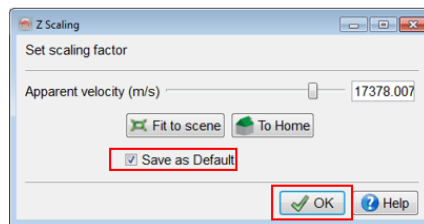
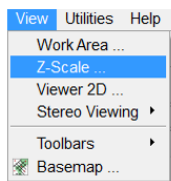
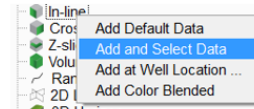

**Workflow cont'd:**

**Saving color settings with stored volumes:**

1. **Select** a color bar.
2. **Right-click** on the color-bar and **select** Ranges/Clipping.
3. **Change** the Percentage clipped and **Apply** a few times. When satisfied **Press** Close.
4. By default, clipping is used meaning every line will be scaled slightly different. To set the extreme values: **manually overwrite** the values next to the color bar and **press** Enter.
5. **Right-click** on an attribute in the tree and **select** Save Color (& scaling) Settings to save it as default for this attribute.

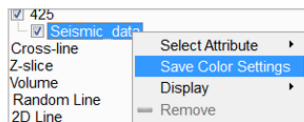
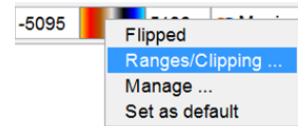
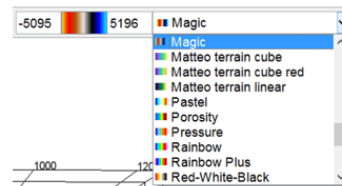

**Workflow cont'd:**

*This is just for information purpose and is not part of the current exercise.*

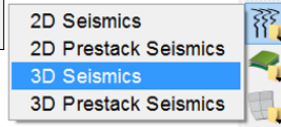

**Manually setting a default data set :**

1. **Press** the Manage Seismic icon and **Select** 3D Seismics or **go to** Survey > Manage > Seismics > 3D.
2. **Select** a Seismic data set from the list and **click** on the Default ★ icon. The default file is marked by the >< symbol.

The advantage of having a default data set is that it saves many clicks to select data in various places in OpendTect. For example in this exercise we used option "Add and Select " to see the data. We then had to select the data. From now on we can use "Add default data" for in-lines, crosslines and Z-slices.

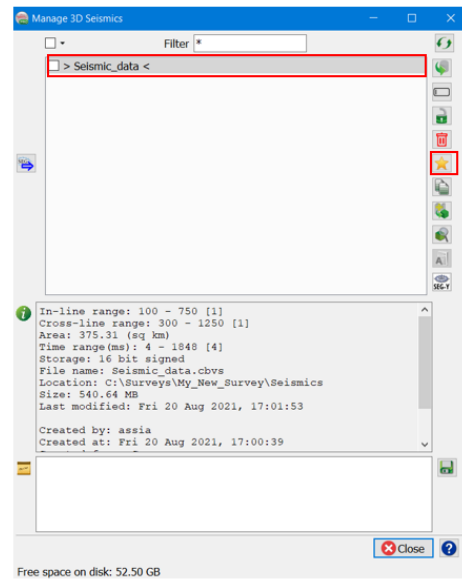



## 2.1.1b Set up Survey using PetrelDirect

Required licenses: OpendTect Pro.

### Exercise objective:

To show how an OpendTect survey can be quickly set up from an existing Petrel\* project using PetrelDirect.

### Workflow:

1. **Choose** Select/Setup option under the Survey menu or **click** on the Survey Setup icon .
2. **Click** on the *Create New Survey* icon  in the *Survey Setup and Selection* window.

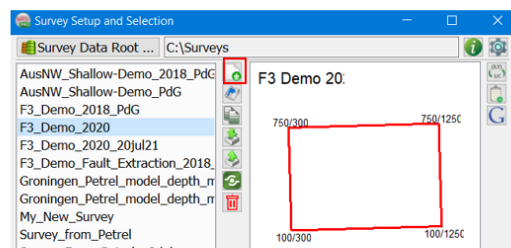
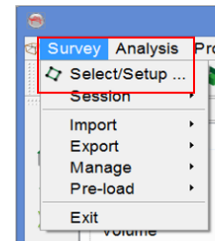

\* Petrel is a mark of Schlumberger

### Workflow cont'd:

3. **Specify** a Survey name; **select** Use PetrelDirect; **Set** Time for Z Domain and **press** Next.
4. **Select** a seismic data set from the Petrel project to set up the OpendTect survey
5. **Press** OK.

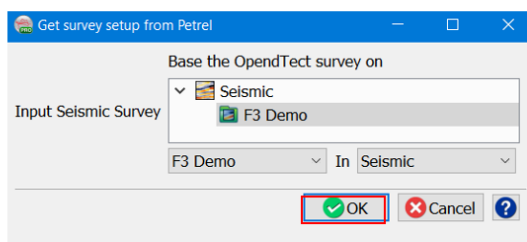
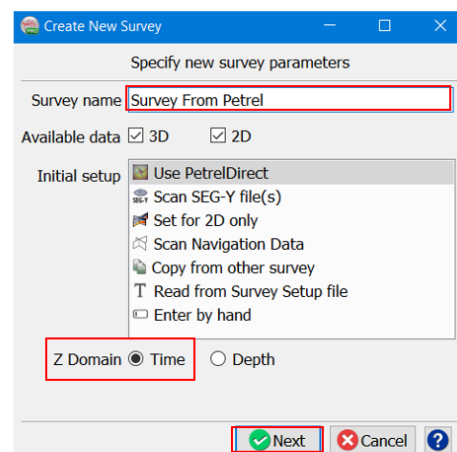

## Workflow cont'd:

- You would see the survey information filled-in automatically from the selected Petrel\* project set-up. **Press OK** to set-up the survey.
- A pop-up message asking if you want to proceed with the data import. **Select No**, if you don't want to proceed with bulk data import from Petrel.

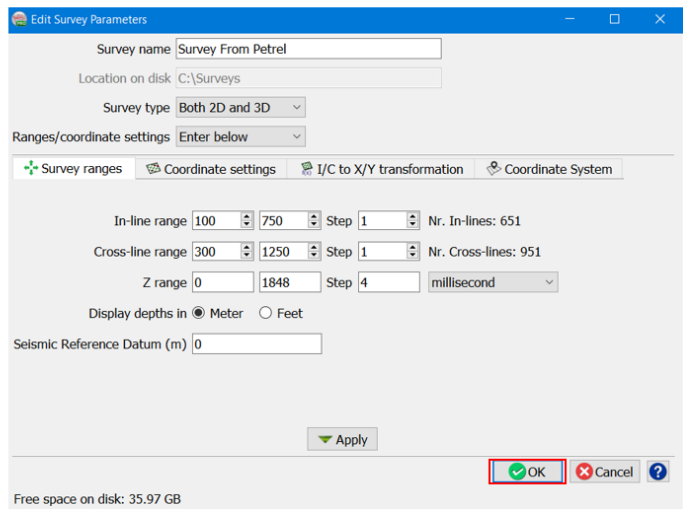
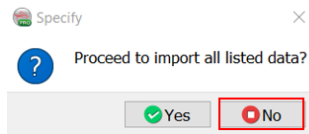

## 1.2.3a Horizon

Required licenses: OpendTect.

### Exercise objective:

Import (geometric) horizons from ASCII files.

### Workflow:

1. **Go to** Survey>Import>Horizon>ASCII>Geometry 3D.
2. In the Import window, **select** the horizon as Input Ascii file: \Rawdata\Surface\_data\F3-Horizon- FS6.yxt for example.

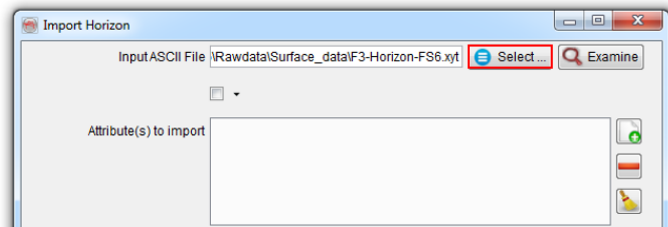
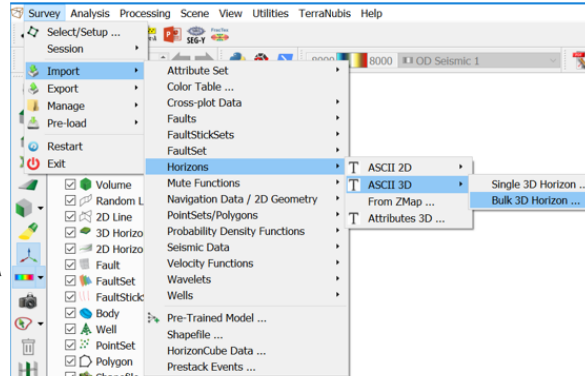

### Workflow cont'd:

3. **Examine** the file to determine the header contents and to check details for the Format Definition.

Keep this window open to fill in the Format Definition.

4. **Specify** the header size (number of lines): here, **set** it to No header.

Optionally define attribute(s) to be loaded as Horizon Data in the same time as the geometry : use the  icon. You can add as many attribute as you need. They will be listed and you can decide to select them for loading.

Attributes can also be imported and added to an already existing horizon by choosing: Survey > Import > Horizon > Attribute 3D...

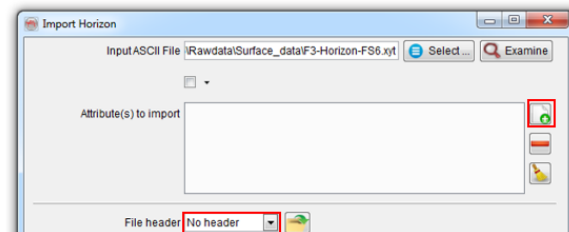
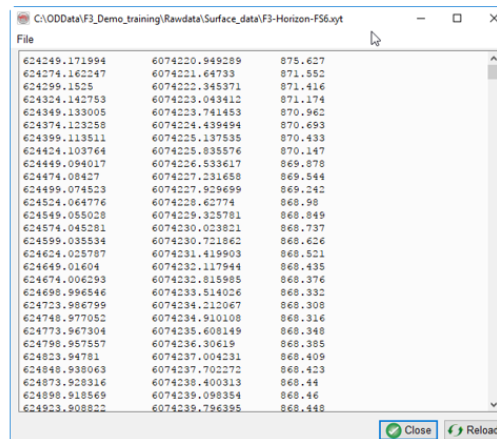

**Workflow cont'd:**

5. To set the Format Definition, **click** on Define : **assign** to each quantity the corresponding column in the file.
6. Optionally, **click** on Scan Input File to test the loading parameters.
7. **Close** the scan report

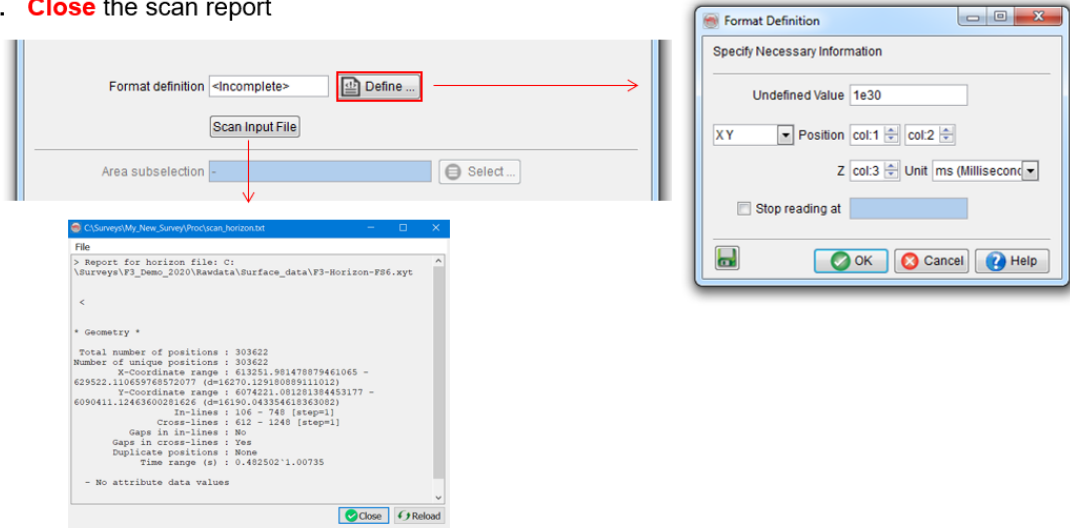

**Workflow cont'd:**

8. **Specify** if the undefined parts should be filled: select No.
9. **Name** the Output Horizon and **select** a color for display.
10. To automatically load the horizon in the 3D scene, **toggle on** the “Display after import” option.
11. **Press** Import.

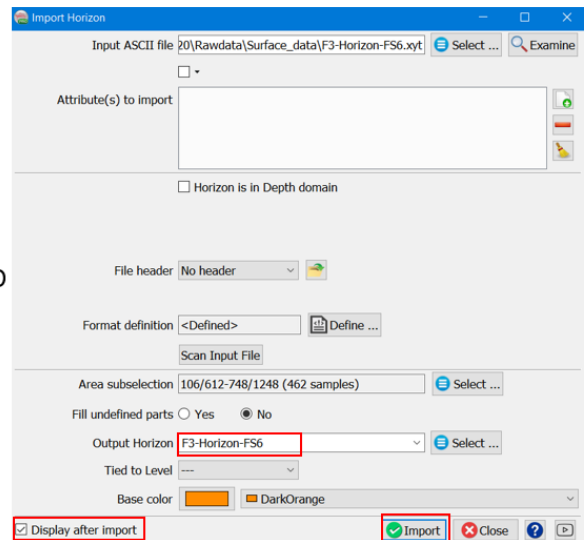

## 1.2.4a Well Data

Required licenses: OpendTect.

### Exercise objective:

To load well data from ASCII and LAS files.

### Workflow:

1. First **import** the well track by choosing Survey > Import > Wells > ASCII > Track.
2. **Select** the Well track file: /Rawdata/Well\_data/F02-01\_welltrack.txt for example.

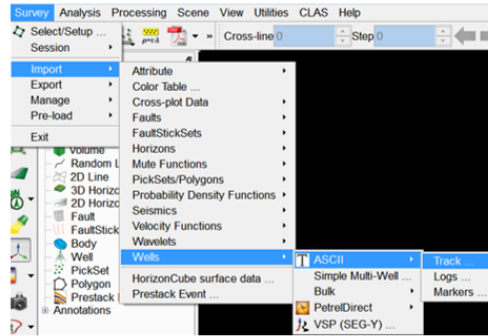

If you select Directional or Vertical Well, you can manually add the well head coordinates.

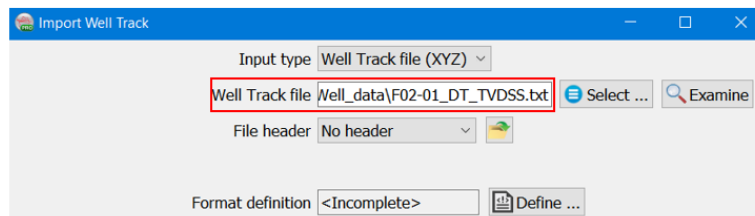

### Workflow cont'd:

3. **Click** on the Examine button.

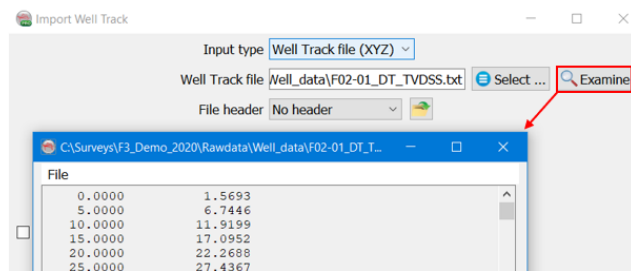

4. **Define** the Format Definition for the well track: col-1: X, col-2: Y, col-3: Z and col-4: MD. The default units are in meters, but can be modified from the drop-down menu.

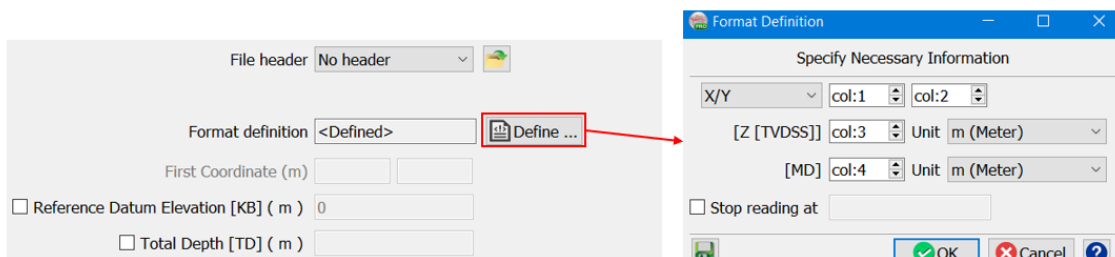



**Workflow cont'd:**

- 5. **Select** the Depth to time model file: /Rawdata/Well\_data/F02-01\_TD.txt.
- 6. **Examine** the file.
- 7. **Define** the Format Definition for the Depth to time model; col-1: Depth in m, col-2: TWT in sec.

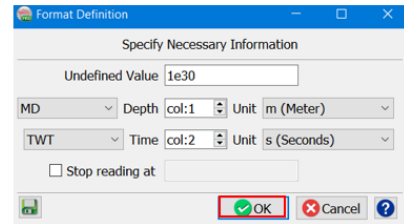
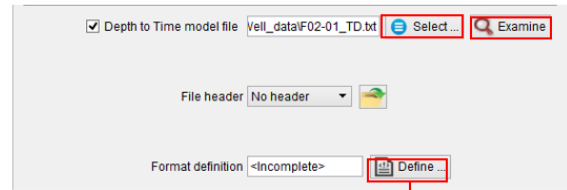

If you uncheck the Depth to Time model file, you will be able to add a constant velocity model for this well.

**Workflow cont'd:**

- 8. Is this checkshot data? **Tick** yes.

Advanced options are optional

- 9. **Provide** an output name.
- 10. Once done, **press** the Import button.

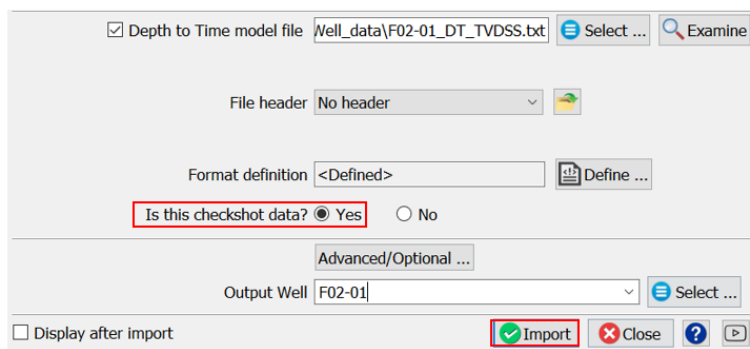

**Workflow cont'd:**

11. Display the well in the survey: **right click** on Well > Load and **select** your well.

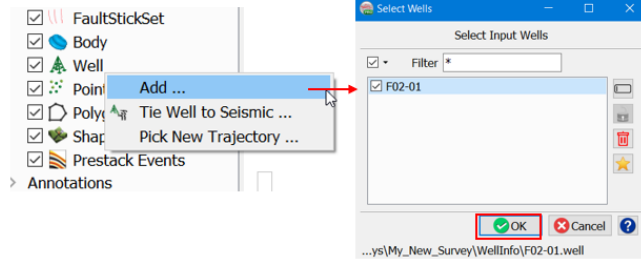

12. To import the logs files: **click** on the Manage Well Data icon and **click** on Import. Alternatively, **follow** Survey > Import > Wells > ASCII > Logs.

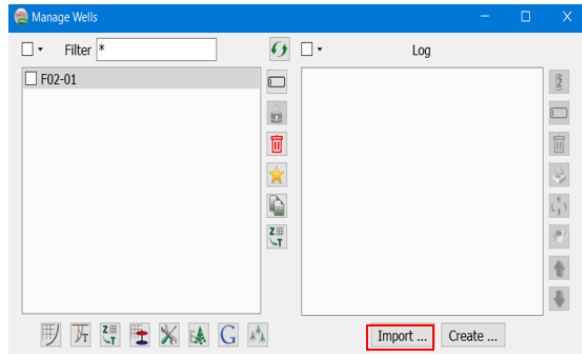

**Workflow cont'd:**

13. **Press** the Import button, then **select** las file: /Rawdata/Well\_data/F02-01\_logs.las.

14. **Toggle** MD.

15. **Highlight** all logs needed to import

16. **Select** Curve in the name after log

17. **Click** on Import.

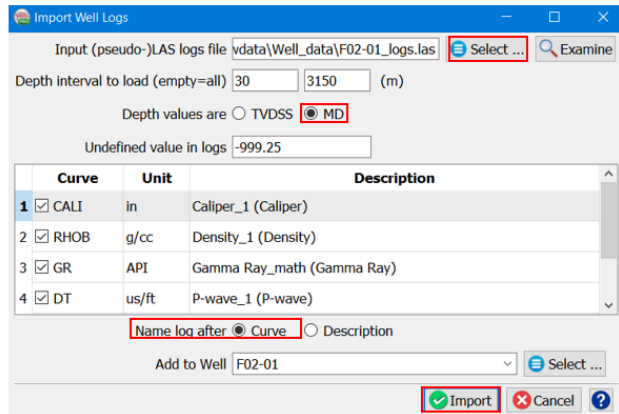

**Workflow cont'd:**

18. In the well manager, **click** the Edit Markers icon.

In this exercise, we will **import** markers from an existing file. It is also possible to add markers manually.

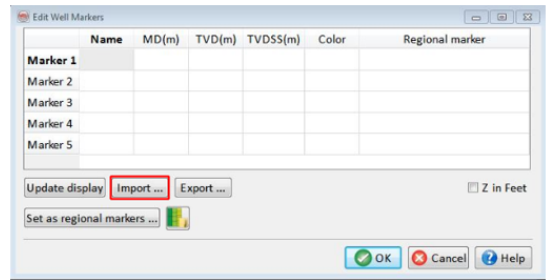
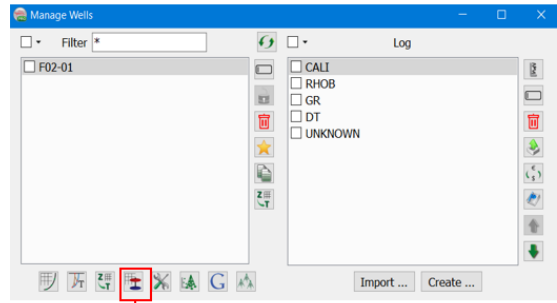

**Workflow cont'd:**

19. **Select** the input file: /RawData/ Well\_data/F02-01\_markers.txt.

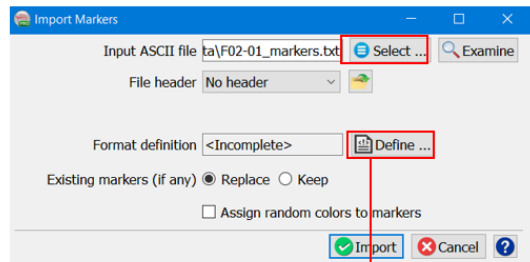

20. **Define** the Format Definition:

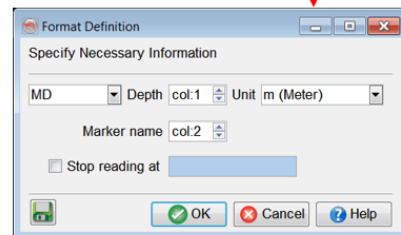

**Workflow cont'd:**

21. **Select / Modify** a color for each marker by **double-clicking** on the appropriate row in the Color column.
22. **Press** OK.
23. Once done, **close** the dialogs and return to OpendText scene.

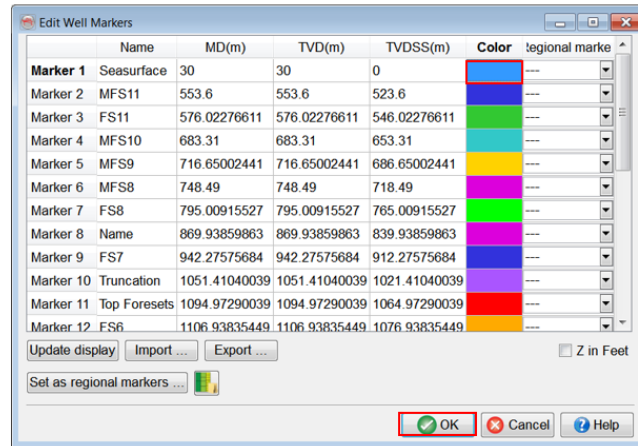

**Workflow cont'd:**

24. In the scene, **display** the log and/or markers on the well : **right click** on the well in the tree and **follow** Display >Properties.
25. In the left-, center- or right-log tab, **select** the log to display and the properties.

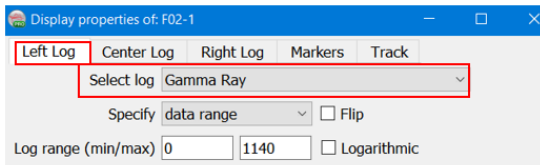
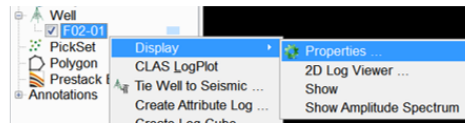

26. **Open** the Markers tab: **toggle** on the desired markers and **set** the marker size etc.

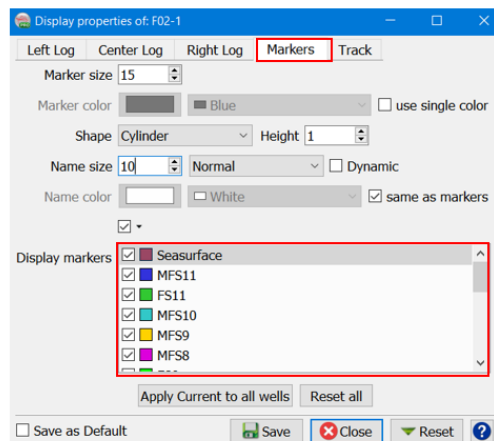

## 1.4.4a Stacking Velocities

Required licenses: *OpendTect*.

### Exercise objective:

Import stacking velocity functions.

### Workflow:

1. **Go to** Survey > Import > Velocity Functions > ASCII... to import a velocity function.

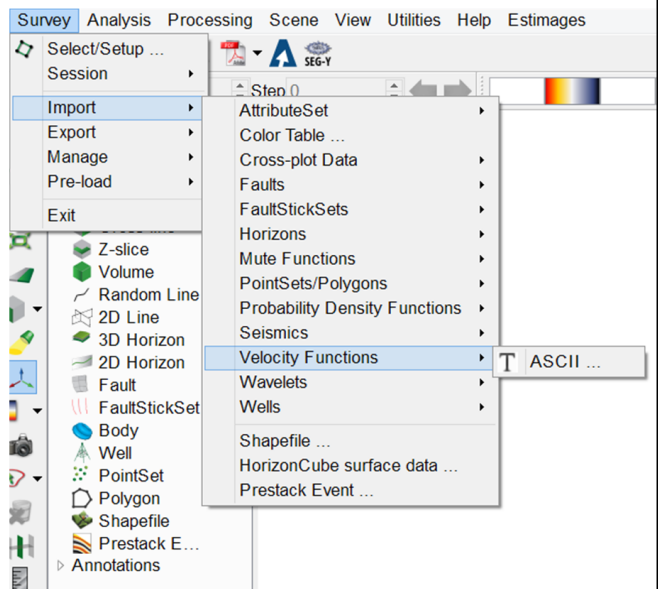

### Workflow cont'd:

2. **Locate** the file *Velocity\_functions.txt* in the *Rawdata* directory and **Examine** the input file.
3. **Select** the velocity type: *Vrms*.

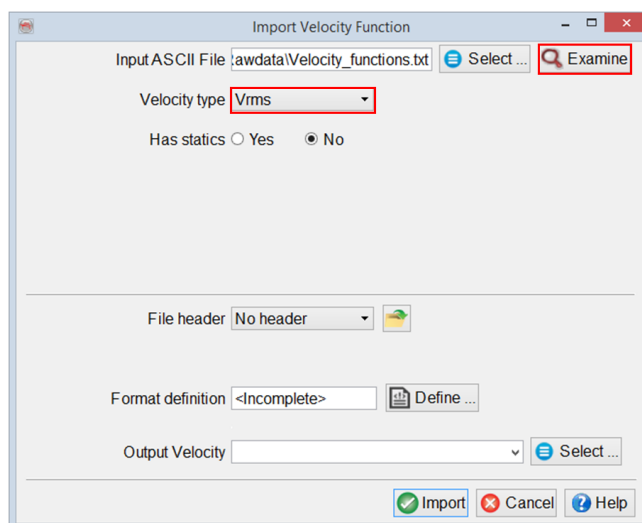

**Workflow cont'd:**

4. **Set** File header to Fixed size consisting of 2 lines.
5. **Define** the format as X-Y-Time-Vrms respectively in column 1, 2, 3, 4.

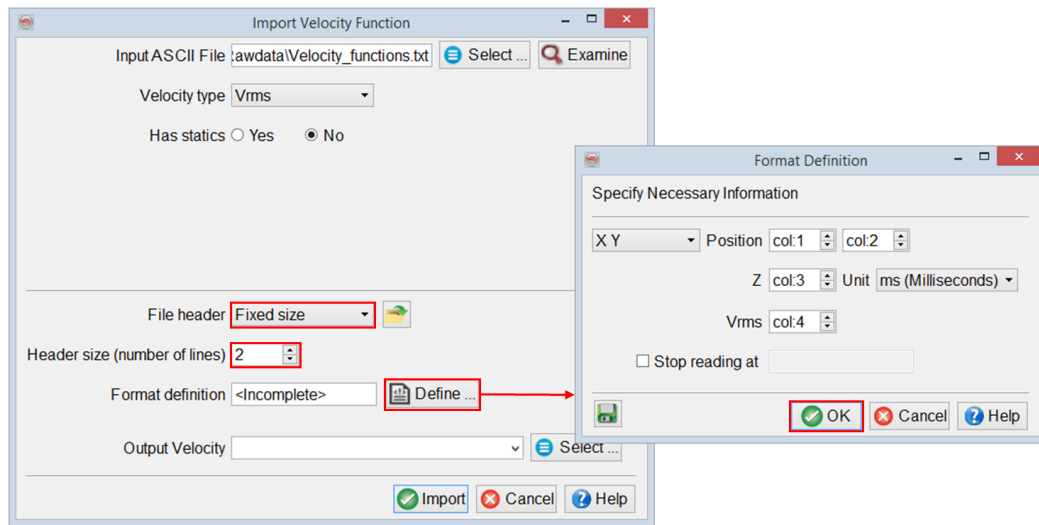

**Workflow cont'd:**

6. **Specify** an Output Velocity name as it would appear in OpenTect, e.g. *Vrms\_function*, and **click** Import.

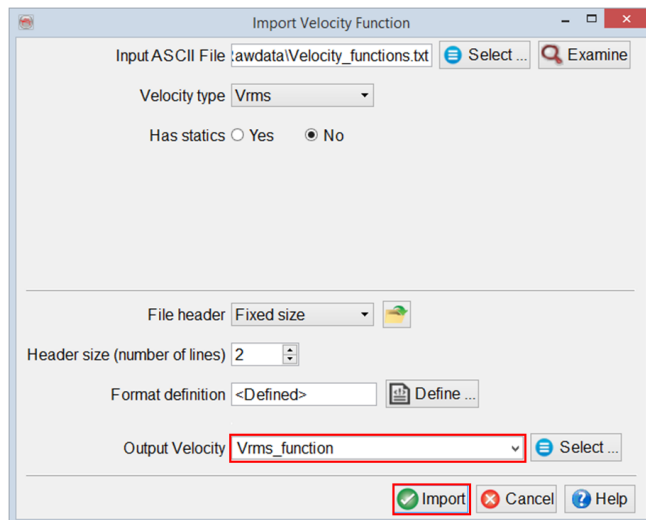

## 2.1.1c Import data from Petrel using PetrelDirect

Required licenses: OpendTect Pro.

### Exercise objective:

Import data from Petrel\* to OpendTect using PetrelDirect.

### Introduction

PetrelDirect is an OpendTect Pro feature for direct data transfer between OpendTect and Petrel\* projects. Reading data from a Petrel\* project is available in various OpendTect workflows via insert icon , which allows to either access data directly from a Petrel\* data store via links or physically data copy to an OpendTect project:

#### Link to Petrel\*:

- no data duplication;
- data is available only when the Petrel\* project is running and PetrelDirect connection is active (i.e. Petrel\* license is tied).

#### OpendTect copy:

- physical copy data in OpendTect format;
- no restrictions on data access (i.e. Petrel\* license is not tied and data is accessible to all users).

Either method gives full potential for manipulation, interpretation and processing. Writing data to a Petrel\* project is also available in various OpendTect workflows by choosing  PetrelDirect output format.

PetrelDirect support the following objects:

- **Full two-way access (Petrel\* <-> OpendTect):**  
Faults and FaultStickSets, 3D horizons, 2D and 3D seismic, Wavelets, Wells (tracks, time-depth models and logs)
- **One way access (Petrel\* > OpendTect):**  
2D horizons, 3D prestack seismic, Wells (markers)

Batch processing for importing objects is now available for Faults, FaultSticks, Horizons and Seismic Cubes.

A check box to use the original name is provided which should be checked in case the same needs to remain identical to the object in the Petrel project. Any name entered into the field adjacent to this will be used as the 'base name' for the objects.

The following exercises will cover some examples of data exchange between Petrel and Opendtect .

### Exercise objective:

Use PetrelDirect to import **all data** in one go from Petrel\* to OpendTect at Survey creation.

### Workflow:

1. Perform the same steps as in Exercise 2.1.1b to set up an OpendTect survey using PetrelDirect, except the last step. At the pop-up message asking if you want to proceed with the data import, **Select Yes**, to proceed with bulk data import from Petrel.
2. **Select** All Objects in the Datatypes and **Hit** OK. For a large amount of data you can use the 'Execute in Batch' option.

Note that 'Datatypes' and 'Filter' can be used to list and select only the data of interest to be loaded.

\* Petrel is a mark of Schlumberger

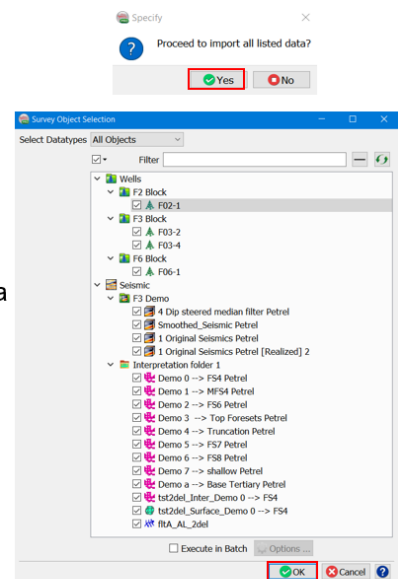

### Exercise objective:

Use PetrelDirect to import **3D seismic** from Petrel\* to OpendTect.

Petrel\* 3D seismic cube can be accessed in OpendTect by clicking on PetrelDirect insert icon  in the following places:

- *Manage 3D Seismics* window (*Survey > Manage > Seismics > 3D...* or click on  icon in the *Manage Data* toolbar)
- *Select* window when adding a seismic attribute display at In-line/Cross-line/Z-slice/3D Horizon in the 3D scene
- Other workflows, including attribute definition and processing, etc.

*Petrel\* seismic data must have compatible geometry with OpendTect survey set up. The easiest way to achieve this is to get survey set up from Petrel\* when setting up a survey and choose an appropriate Petrel\* seismic survey folder as the geometry source.*

### Workflow:

1. **Perform** the same steps as in Exercise 2.1.1b to set up an OpendTect project using PetrelDirect.
2. **Select** Survey < Import < Seismic Data < PetrelDirect < Cube. **Select** the Seismic cube from the *Import Petrel Seismic Cube* window.
3. **Create** either *Link to Petrel\** or *OpendTect Copy*. Note that the *Link to Petrel* option, requires Petrel License to be able to use the seismic in OpendTect.
4. **Keep** the default parameters. **Tick** *Use Original Name Output Cube* and **Hit** Run.

\* Petrel is a mark of Schlumberger

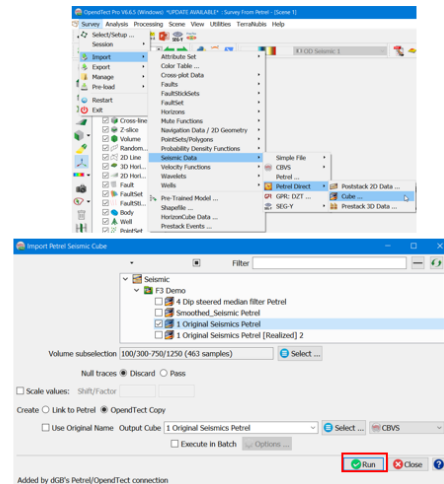

### Exercise objective:

Use PetrelDirect to import **Faults** from Petrel\* to OpendTect.

Petrel\* fault interpretation can be accessed in OpendTect as Faults by clicking on PetrelDirect insert icon  in the following places:

- *Manage Fault* window (*Survey > Manage > Faults...* or click on  icon in the *Manage Data* toolbar)
  - *Select Input Fault(s)* window when adding Fault(s) to the 3D scene, 2D viewer or Basemap by right click on *Fault* in the tree > *Add*)
- This workflow is similar to import FaultStickSets from Petrel to OpendTect.

### Workflow:

1. **Perform** the same steps as in Exercise 2.1.1b to set up an OpendTect project using PetrelDirect.
2. **Select** Survey < Import < Faults < PetrelDirect. **Select** the Fault from the *Import Fault* window.
3. **Create** either *Link to Petrel\** or *OpendTect Copy*. Note that the *Link to Petrel* option, requires Petrel License to be able to use the Fault in OpendTect.
4. **Keep** the default parameters. **Tick** *Use Original Name Output Cube* and **Hit** Run.

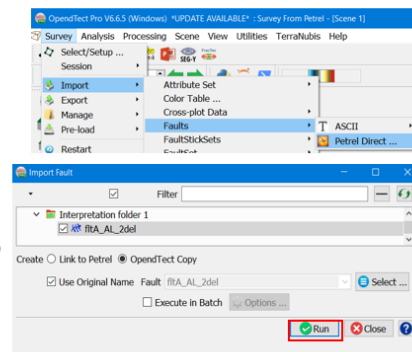

*Note that OpendTect does not support crossing fault sticks (a fault plane cannot cross itself). If faults were picked on inlines, crosslines and horizontal slices, only the largest subset of the three will be used to import the faults. Manual editing (removing unwanted sticks) is possible after import and might be required in some cases.*

\* Petrel is a mark of Schlumberger



### Exercise objective:

Use PetrelDirect to import **3D Surfaces** from Petrel\* to OpendTect.

Petrel 3D horizons and surfaces can be accessed in OpendTect by clicking on PetrelDirect insert icon  in the following places:

- *Manage 3D Horizons* window (*Survey > Manage > Horizons > 3D...* or click on  icon in the *Manage Data* toolbar)
  - *Select Input Horizon(s)* window when adding 3D Horizon to the 3D scene, 2D viewer or Basemap by right click on *3D Horizon* in the tree > *Add*)
  - Other workflows, including 3D Horizon gridding and filtering, creating flattened scene, etc.
- This workflow is similar to import 2D Horizon from Petrel to OpendTect.*

### Workflow:

1. **Perform** the same steps as in Exercise 2.1.1b to set up an OpendTect project using PetrelDirect.
2. **Select** Survey < Import < Horizon < PetrelDirect < 3D Horizons. **Select** the Horizon (s) from the *Import Petrel Horizon* window.
3. **Create** either *Link to Petrel\** or *OpendTect Copy*. Note that the *Link to Petrel* option, requires Petrel License to be able to use the Horizon in OpendTect.
4. **Keep** the default parameters. **Tick** *Use Original Name* *Horizon* and **Hit** Run.

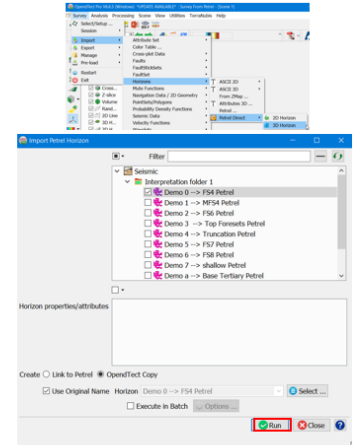



*OpendTect project is based on a particular 3D survey set up. Petrel\* 3D horizons associated with 3D seismic surveys which geometries are different and Petrel\* surfaces based on grids which are different are snapped to an OpendTect grid during import.*

\* Petrel is a mark of Schlumberger

### Exercise objective:

Use PetrelDirect to import **Wells** from Petrel\* to OpendTect.

Petrel well data (deviation survey, time-depth model, logs and well tops) can be accessed in OpendTect by clicking on PetrelDirect insert icon  in the following places:

- *Manage Well* window (*Survey > Manage > Wells...* or click on  icon in the *Manage Data* toolbar)
- *Load Well(s)* window when adding well(s) to the 3D scene or Basemap by right click on *Well* in the tree > *Add*)
- Other workflows, including well-to-seismic tie, Log attribute definition and processing, etc.

### Workflow:

1. **Perform** the same steps as in Exercise 2.1.1b to set up an OpendTect project using PetrelDirect.
2. **Select** Survey < Import < Wells < PetrelDirect. **Select** the Wells(s) from the *Import Petrel Well* window.
3. **Create** either *Link to Petrel\** or *OpendTect Copy*. Note that the *Link to Petrel* option, requires Petrel License to be able to use the Wells in OpendTect.
4. **Keep** the default parameters and **Hit** OK.

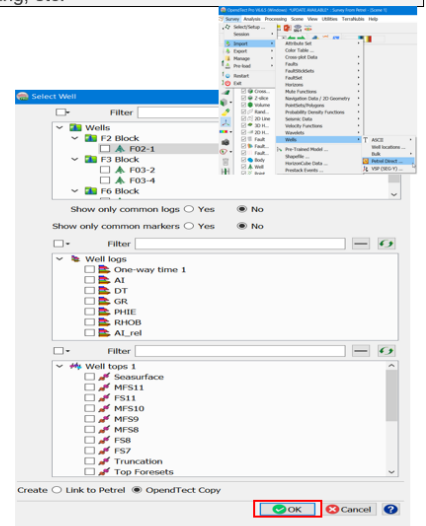



Selection of well logs and markers can be done using the Filters, Show only common logs/markers switch, then Select buttons.

\* Petrel is a mark of Schlumberger

### Exercise objective:

Use PetrelDirect to import **Wavelet** from Petrel\* to OpendTect.

Petrel\* wavelets can be accessed in OpendTect by clicking on PetrelDirect insert icon  in the following places:

- *Manage Wavelets* window (*Survey > Manage > Wavelets* or click on  icon in the *Manage Data* toolbar)

### Workflow:

1. **Perform** the same steps as in Exercise 2.1.1b to set up an OpendTect project using PetrelDirect.
2. **Select** Survey < Import < Wavelets < PetrelDirect. **Select** the Wavelets (s) from the *Import Petrel Wavelet* window.
3. **Create** either *Link to Petrel\** or *OpendTect Copy*. Note that the *Link to Petrel* option, requires Petrel License to be able to use the Wavelet(s) in OpendTect.
4. **Keep** the default parameters and **Hit Run**.

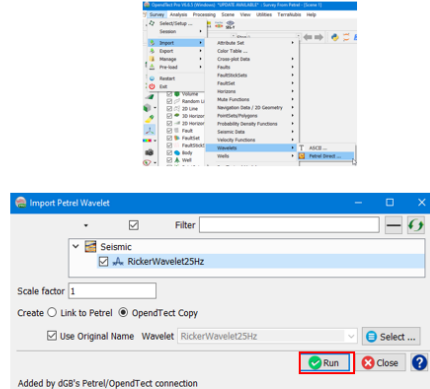

\* Petrel is a mark of Schlumberger

### Exercise objective:

Use PetrelDirect to import **Pointsets and Polygons** from Petrel\* to OpendTect.

Petrel pointsets and polygons can be accessed in OpendTect by clicking on PetrelDirect insert icon  in the following places:

- *Manage Pointset/Polygons* Windows (*Survey > Manage > Pointsets/Polygons...* or click on the  icon in the *Manage Data* toolbar). When adding from PointSet/Polygon manager, user will have a selection box to choose which kind of object they want to import from Petrel\*
- *Load Pointsets (Polygons)* window when adding pointsets (polygons) to the 3D scene or Basemap by right clicking on *Pointsets (Polygons)* in the tree > *Add*. The relevant dialog box pops up.

### Workflow:

1. **Perform** the same steps as in Exercise 2.1.1b to set up an OpendTect project using PetrelDirect.
2. **Select** Survey < Import < Pointsets/Polygons < PetrelDirect < Polygons (or Pointsets). **Select** the Polygons (s) from the *Import Petrel Polygons* window.
3. **Create** either *Link to Petrel\** or *OpendTect Copy*. Note that the *Link to Petrel* option, requires Petrel License to be able to use the Polygons/Pointsets in OpendTect.
4. **Keep** the default parameters, Use Original Name and **Hit Run**.

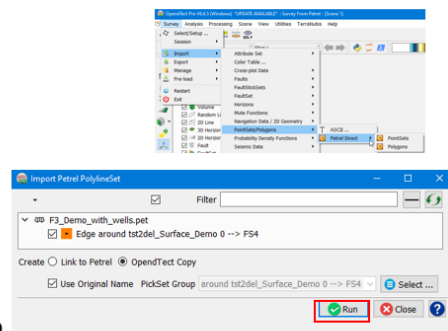

\* Petrel is a mark of Schlumberger

---

## 1.3.1a Display An Inline

*Required licenses: OpendTect.*

### Exercise objective:

Display an inline in the 3D scene.

### Workflow:

1. **Right-click** on Inline in the tree and **select** Add and Select Data.
2. In the pop up window, **select** 4 Dip steered median filter.
3. **Click** OK to display data in the scene.

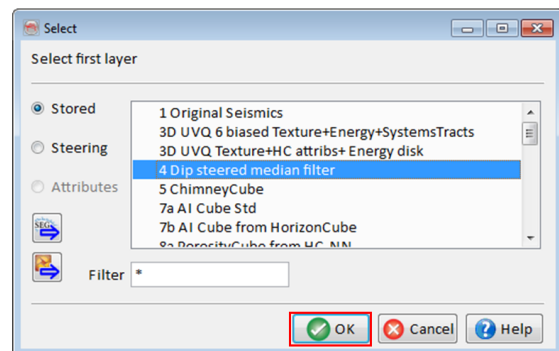
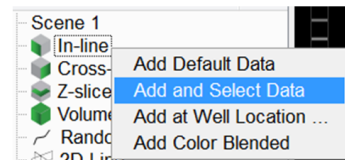

Visualization and processing goes faster when you load the relevant data set(s) into memory. If you do not have sufficient memory to load an entire volume load only the part you intend to work on. Another way to reduce memory consumption is to re-scale data to 8-bit during pre-load.

## 1.3.1b Pre-load Data

Required licenses: OpendTect.

**Exercise objective:**  
Pre-load data

**Workflow:**

1. Use it only if you have sufficient memory. To **Pre-load** a stored seismic cube **go to** Survey > Pre-load > Seismic.

2. **Click** on Add Cube.

In the lower-right corner of the main window you can see how much memory is free.

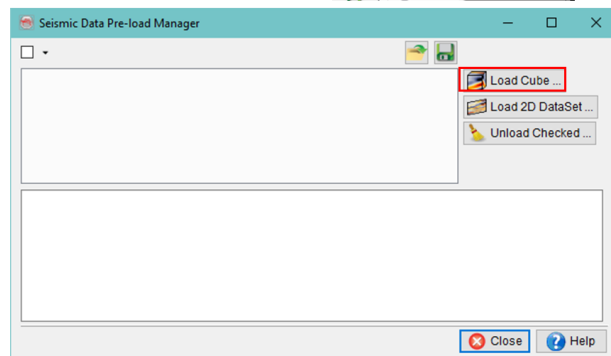
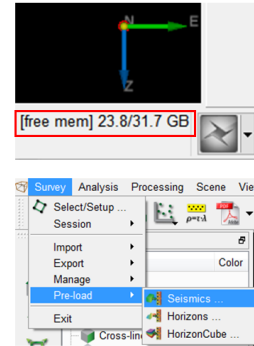

**Workflow cont'd:**

3. **Select** 4 Dip steered median filter as input cube. Optionally, **specify** a volume subselection and the loading format. **Press** OK.

To reduce memory consumption:  
1) load in a smaller volume range  
2) load in a different format e.g. as 8-bit

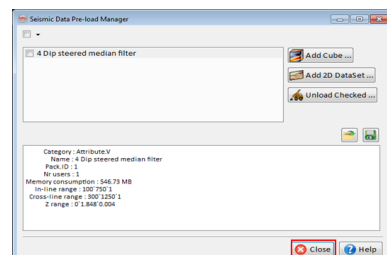
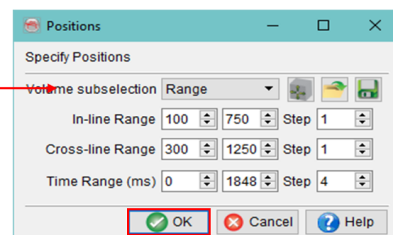
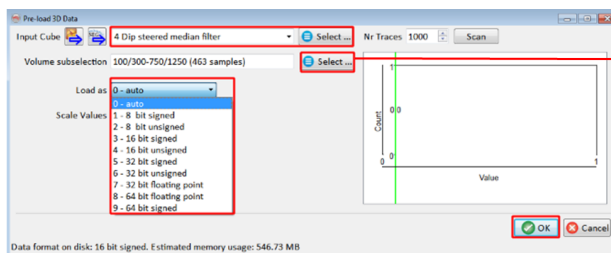

## 1.3.2a Position, Zoom, Pan, Rotate

Required licenses: *Opentect*.

### Exercise objective:

Learn how to zoom, pan, & rotate a 3D scene and how to move a seismic line.

### Workflow:

1. **Click** on shift + the mouse wheel and drag to **rotate** your display. To **pan** the scene (i.e. move the scene horizontally & vertically) **press** the scroll wheel (keep it pressed on) and **move** the mouse.
2. **Zoom** in and out by scrolling the mouse wheel. Or **press** Ctrl + the mouse wheel (keep it pressed on) and **move** the mouse back and forth.



### Workflow cont'd:

#### Positioning elements

3. **Click** on In-line in the tree > **Add Default Data**.
4. **Select** the inline in the tree by clicking on the line number 425.
5. **Fill in** 250 (the new inline position) line number in the Slice Position toolbar.

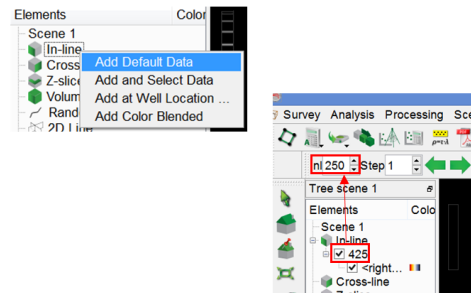

Use available memory: **pre-load** 2D, 3D, pre-stack seismic, Horizon and **HorizonCube** for quicker access.  
**Survey > Pre-load > Seismics**

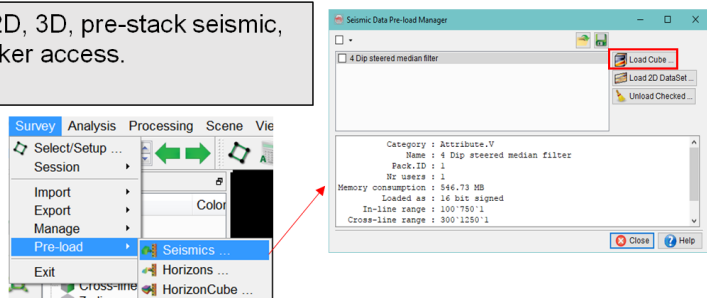

**Workflow cont'd:**

**Positioning elements**

6. **Rotate** the view so you see the inline such that it is displayed from its side' or 'end on' as much as possible in the scene.
7. **Left click** (keep the button pressed) on the inline in the scene and **drag** it to the desired location and let it go.
8. To undo **press Ctrl + Z**.

If the seismic is pre-loaded the display is uploaded instantaneously, movie-style.

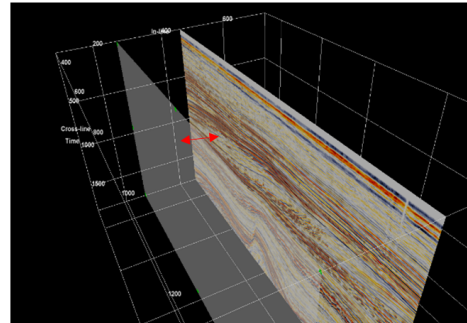

**Workflow cont'd:**

**Positioning elements**

9. From the tree, **right-click** on the updated inline number and **select** Display > Position option in the pop-up menu list.
10. **Position** the inline at 195 and **click** OK.

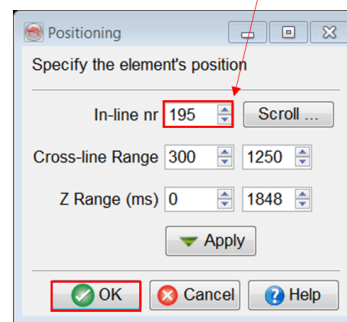
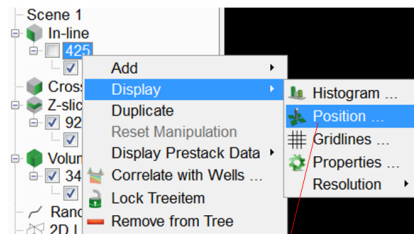

**Workflow cont'd:**

**Positioning elements**

- 11. Scrolling: **Right-click** on an In-line number and **select** Display > Position. **Press** Scroll. Elements are moved either manually (**select** Control Manual) or automatically (**select** Control Auto).

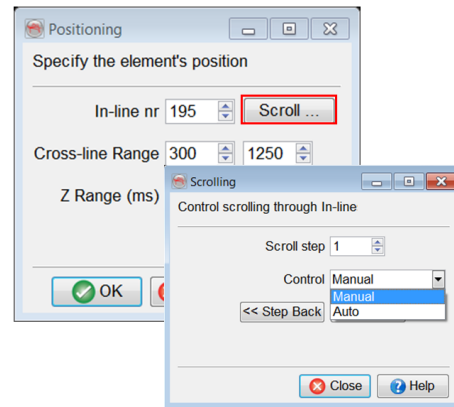

- 12. Default keyboard short cuts to move a slice backwards/forwards are x and z. To change this **go to** Utilities > Settings > Keyboard shortcuts.

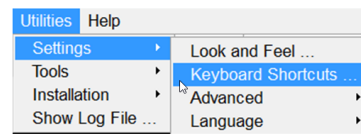

**Workflow cont'd:**

**Positioning elements**

- 13. In the element tree **right-click** on Volume and **select** Add. This will insert an empty element in the tree.

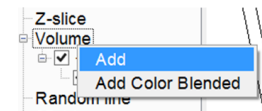

- 14. **Select** a stored volume: **right-click** on <right-click> and **go to** Select Attribute > Stored Cubes > 4 Dip steered median filter.



- 15. **Left-click and drag** an in-line/cross-line/z-slice, you can then go quickly through the entire volume.

### Workflow cont'd:

Look at what you have from all sides. Note that the data values are read out and displayed in both methods (view mode and position mode), these values are displayed at the bottom of the screen.  
Show crossline 1000 in a similar manner.

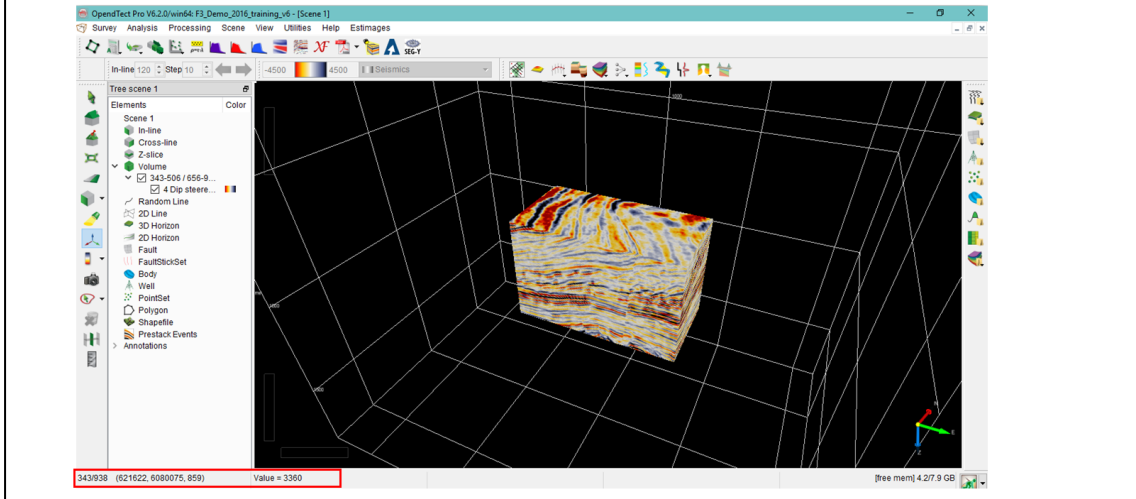

### Workflow cont'd:

Show a part of a Z-slice at 700 ms TWT

16. **Right-click** on Z-slice > Add Default Data.
17. **Rotate** the view so you see the Z slice from above. Shift + Middle Click + Drag.
18. **Make** the frame smaller by dragging the green handle points of the frame. (If the handles are not apparent **click** on the relevant slice to 'activate' them).
19. **Right-click** on the Z-slice number > Display > Position. **Change Z (ms) to 700** and **press OK**.

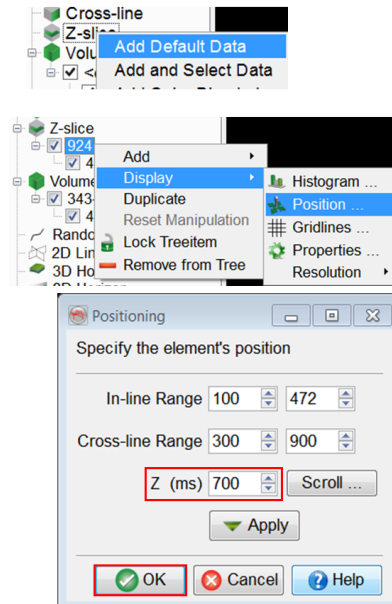



## 1.3.3a Random Line

Required licenses: *OpendTect*.

### Exercise objective:

Add a random line and move & rotate this through a 3D seismic volume.

### Workflow:

1. **Pre-load** the stored 4 *Dip steered median filter* cube (see exercise 1.3.1b).
2. Add a random line: **right-click** on the tree item (OpendTect Pro users can also do this from the basemap).
3. Resize the display element: **left-click + drag** on the green anchors (this is optional but for the sake of this exercise let's do it).

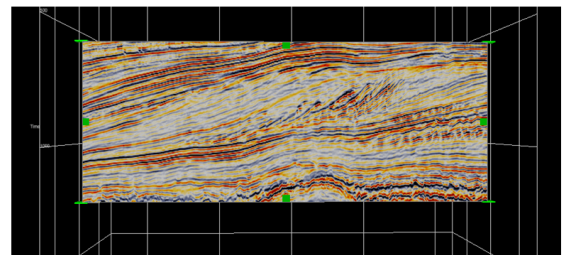
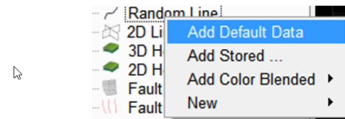

### Workflow cont'd:

4. Push the line through the seismic volume: **left-click + drag**.
5. Rotate the line: **Ctrl left-click + drag**.
6. Push the line through the volume in the new direction: **left-click + drag**.

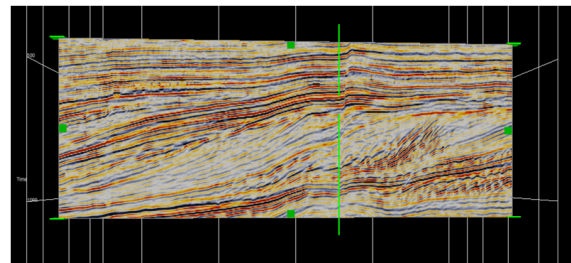

**Workflow cont'd:**

7. Insert a node: **right-click** on the element in the scene, or the entry in the tree and
8. Use the green anchors to position the node: **left-click + drag**
9. As before, now push and rotate the crooked line through the volume using **left-click + drag** and **Ctrl left-click + drag**, respectively.

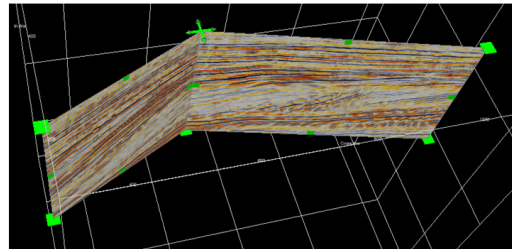
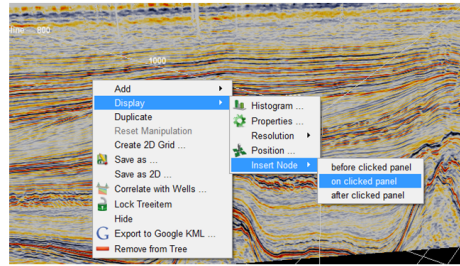

## 1.3.3b Random Line Through Wells

Required licenses: OpendTect.

### Exercise objective:

Create a random line through existing wells.

### Workflow:

1. **Right-click** on Random line > New > From Wells.
2. **Select** all four available wells and **change** the well's order accordingly: F03-4, F03-2, F02-1, F06-1, using *Change order* arrows.
3. **Press** the Preview button to see the updated geometry in the scene.
4. **Give a name** to the newly created Random line and **click** OK.

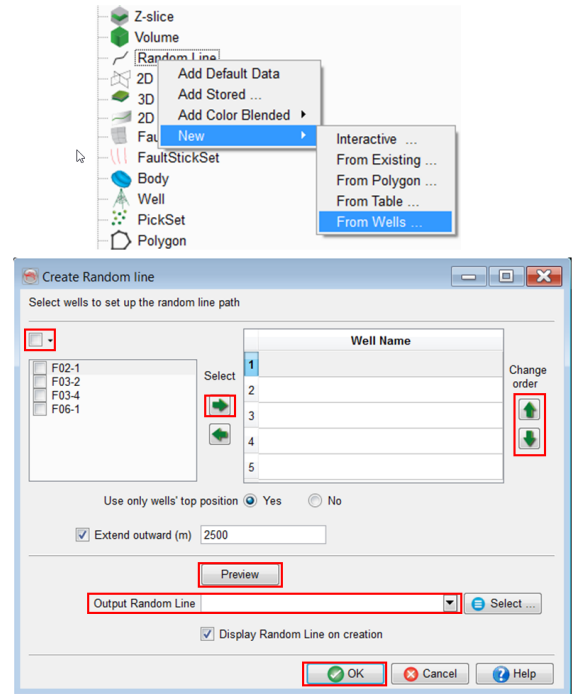

## 2.1.2a Basemap

Required licenses: *OpendText Pro.*

### Exercise objective:

Use the Basemap to populate/manipulate the 3D scene.

1. **Pre-load** *4. Dip steered median filter* (optional, see Exercise 1.3.1b for details).
2. To open the basemap, **click** on the  icon or **go to** View > Basemap.
3. **Add** an inline to the basemap and the 3D scene\*. This can be done in 3 ways:
  - a) **Press** (once) **keyboard I** and drag the line to the correct position : the line number is shown in the tree and in the lower left corner.
  - b) **Move** the cursor in the basemap to the correct position; **right-click** and **Add Inline**.
  - c) **Right-click** in the basemap tree > Add.

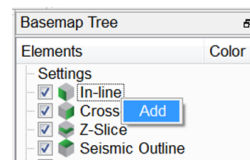
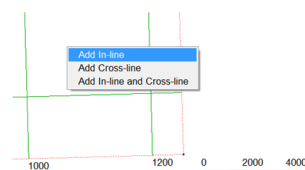
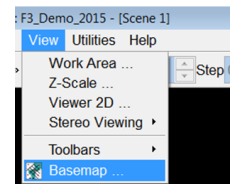

The basemap can be used: 1) to populate a 3D scene; 2) to pop up 2D viewers; and 3) as standalone utility, e.g. when creating output maps. All options are controlled from the Synchronization menu.

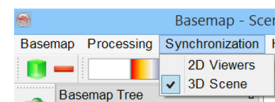

### Workflow cont'd:

4. **Move** the inline to a new position: **hover** over the inline until it shows up in bold; **left-click** and **drag** to the new position\*.
5. **Add** a crossline with **pressing** (once) keyboard C.
6. **Add** a random line **pressing** keyboard R; **Left-click** to add corner points and **double-click** to end the line.

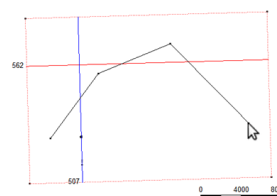
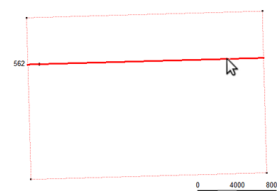

To insert a new node after the random line is drawn:  
Hover over the random line until it shows up in bold and then **shift + click**.  
To delete a node **ctrl + click** on it.

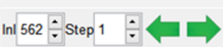
\*If the basemap is synchronized with the 3D scene (as in this exercise) you can also reposition elements using all options supported in the 3D scene, e.g. .

**Workflow cont'd:**

7. **Right-click** on Well in the basemap tree and **select** Create Group.
8. **Add** F02-1 and F03-2 to the group.
9. **Right-click** on the Group and **select** Properties.  
For the sake of the exercise let's assume these wells are oil wells: **select** the corresponding Well symbol and **change** size to 5.
10. **Repeat** the exercise for F03-4 and F06-1: **Give** another well symbol to these two, say oil and gas.

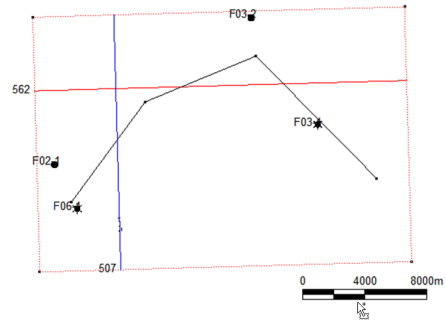
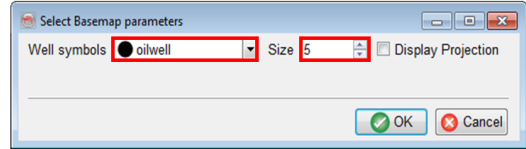
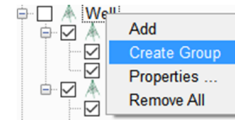

**Workflow cont'd:**

11. **Add** other elements (horizon, contour, shapefiles, ...) and **change** the basemap settings (**right-click** on Settings).
12. To create final maps you can process your horizon before printing: under the **Processing** menu you will find options for filtering or gridding.

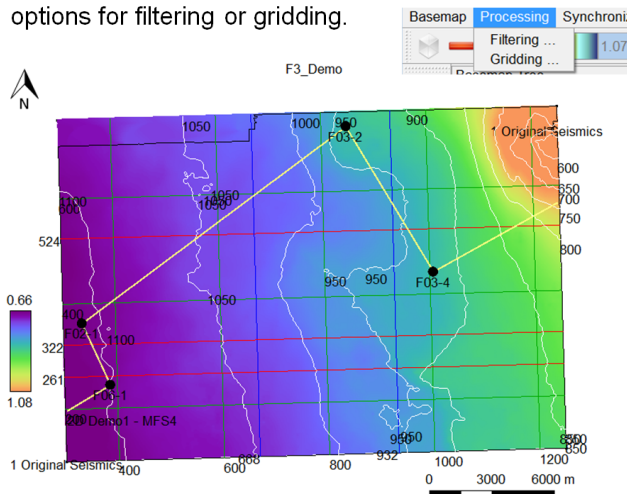
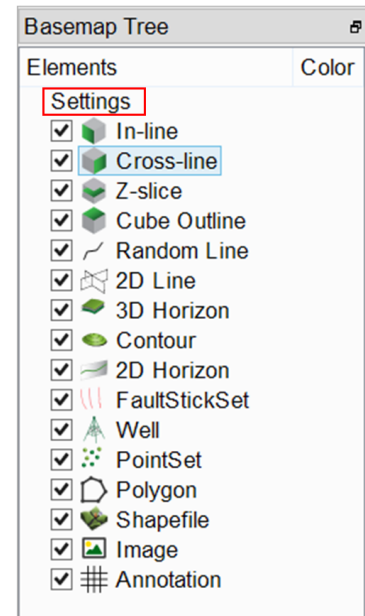

## 2.1.3a PDF3D

Required licenses: OpendText Pro.

### Exercise objective:

Grab a 3D scene with PDF-3D for sharing via Acrobat Reader

### Workflow:

1. Prepare the scene you wish to capture and **press** the drop down sign adjacent to PDF-3D icon . **Select** Save scene as...
2. **Specify** the Output PDF file name (e.g. *Example\_pdf3d*) and **select** Half the resolution for the horizons.

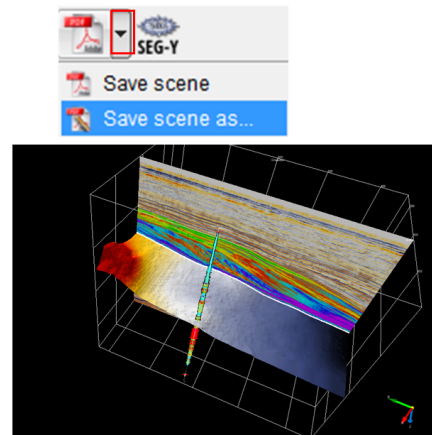
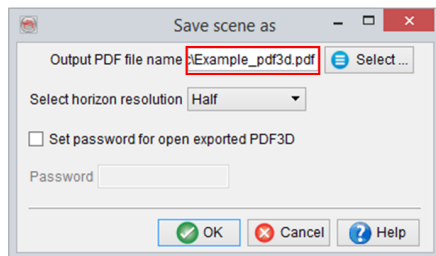

### Workflow cont'd:

3. **Open** the file in Acrobat Reader v8 (or higher).
4. Ensure that double-sided rendering is enabled.
5. **Use the left most icon** on the toolbar to zoom, pan, rotate etc.
6. **Use the tree** to toggle elements on and off.

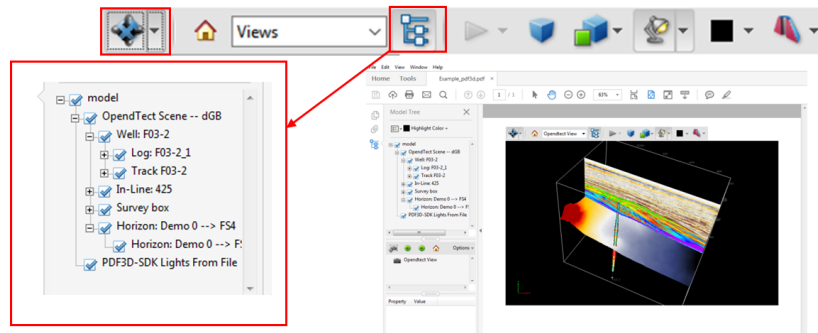
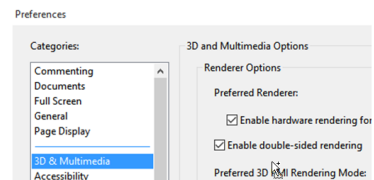

## 2.3.1a Steering Cube

Required licenses: OpendTect Pro, Dip Steering.

### Exercise objective:

Compute a SteeringCube.

### Workflow:

1. **Bring up** the Create Steering Seismics window: **Processing > Dip Steering > Create > 3D**.
2. **Select 1 Original Seismics** as input.
3. **Keep** the default calculation stepout for the PCA steering algorithm 1,1,1.

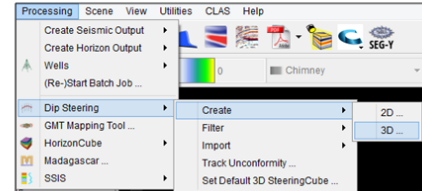

With a calculation stepout of 1,1,1; the dip is computed within a small cube of 3x3x3 samples around each sample in consideration.

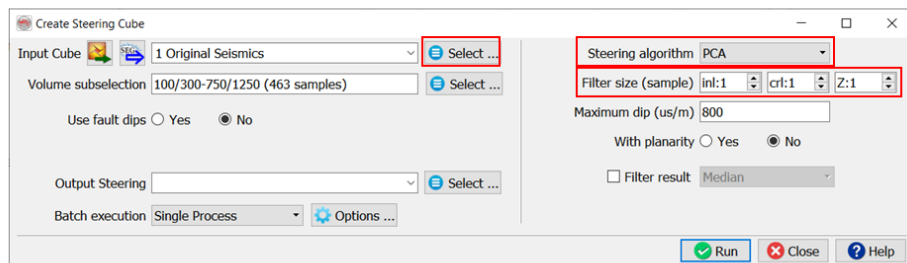

### Workflowcont'd:

4. **Specify** a stepout of 2,2,5 to apply a median filter on the raw dips.

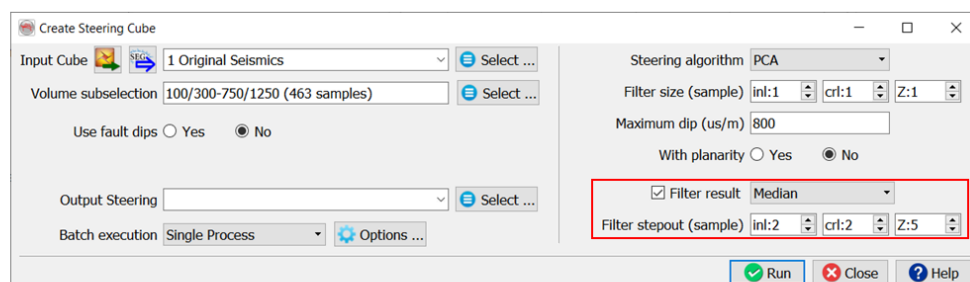

When adding **Planarity**, the output steering cube contains an additional Planarity component along with the Inline Dip and Crossline Dip. The Planarity attribute returns the quality of the steering cube and is used by Unconformity Tracker, Inversion + tracker and for HorizonCube creation.

**Workflow cont'd:**

5. **Set** Volume Subselection for only 10 in-lines, e.g. between 420-430, to save time run this process .
6. **Give** the output SteeringCube a name (e.g. *PCA111\_MF225*) and **click** OK.

Tip: It's recommended to use the SteeringCube parameters in its name, as done in this exercise.

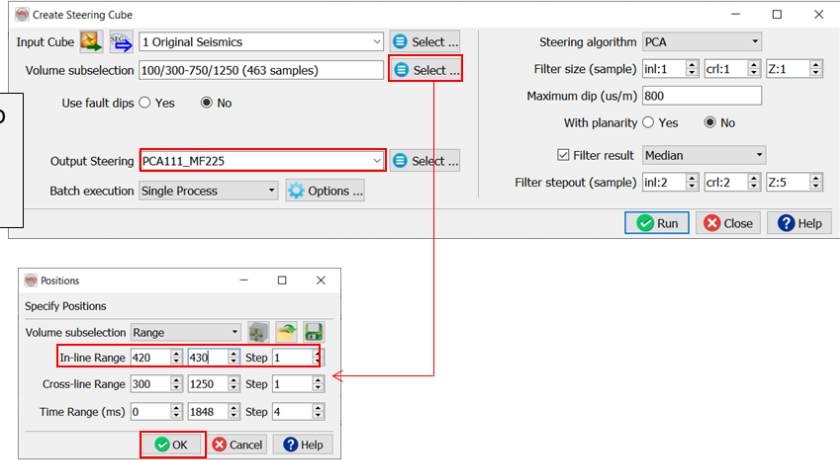

**Workflow cont'd:**

7. **Add** default data (i.e. 4 Dip steered median filter) by **right-clicking** on inline 425.
8. Once again **right-click** on inline 425 to display the Detailed SteeringCube (select *PCA111\_MF225* from Steering tab).

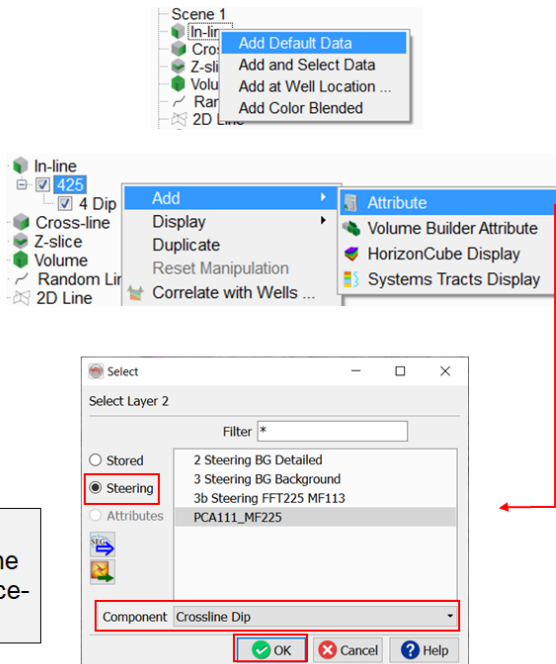

Tip: It's recommended to display the Crossline dip component of the SteeringCube on an inline and vice-versa.



**Workflowcont'd:**

- 9. Use the *Pastel* color-bar.
- 10. To co-visualize seismic and cross-line component of dip, **right-click** on the PCA111\_MF225 in the tree > Display > Change Transparency and **set** the transparency to 50%.

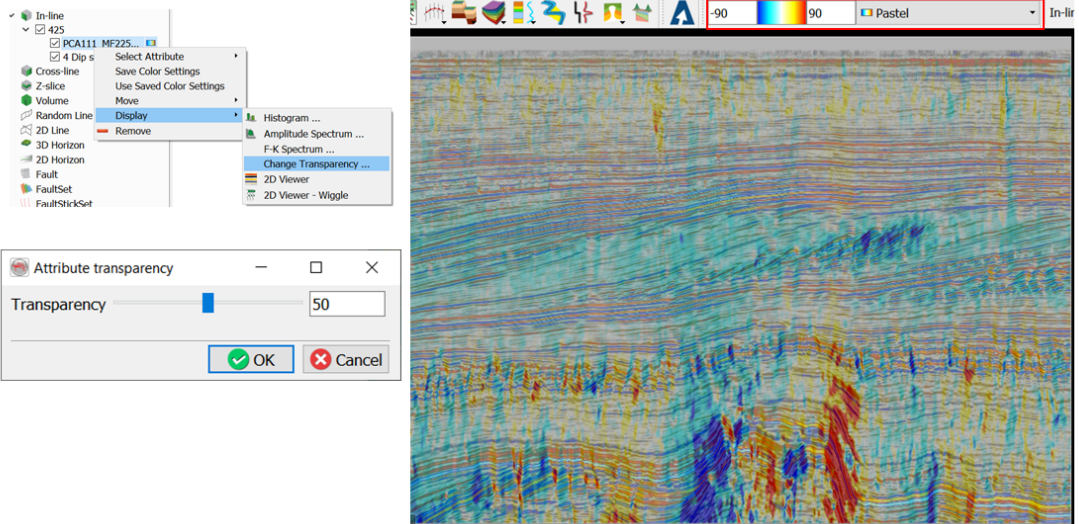

**Workflowcont'd:**

- 11. Additional step: **Go to** Processing > Dip Steering > Filter > 3D and apply Recursive Gaussian filter using the stepout of 5, 5, 2 to achieve smoothly looking results.

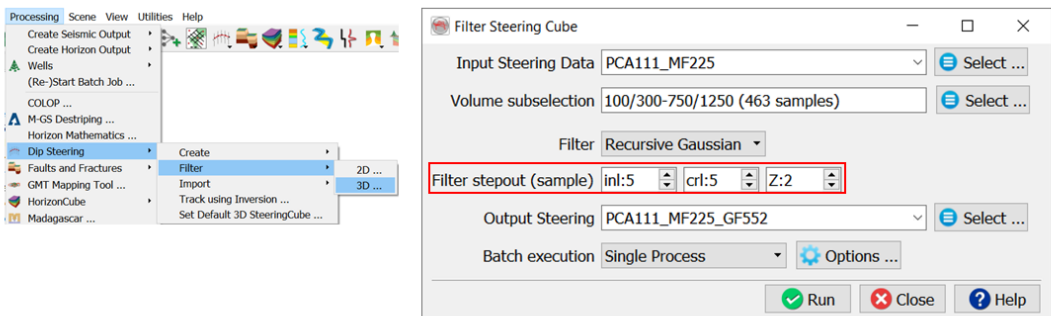

Tip: **Recursive Gaussian filter** is extremely fast and is available for all OpendTect Pro users. If you're using a free version of OpendTect, for additional smoothing we recommend applying the **Average filter**, instead of the Median one. Median filter was already applied during the steering cube computation to remove spikes (step 5 of this exercise).

## 2.3.1d Dip-steered Median Filter

Required licenses: OpendTect Pro, Dip-steering.

### Exercise objective:

Remove random noise from the seismic data using Dip-Steered Median Filter (DSMF).

### Workflow:

1. **Go** to the Attribute engine: Analysis > Attributes > 3D

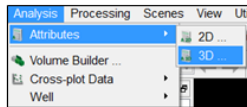

or **click** on the  icon > 3D.

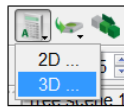

### Workflow cont'd:

2. **Select** the attribute: Dip steered median filter.
3. **Select** Input Data: *1 Original Seismics*.
4. **Set** the step-out to 1, 1 (the optimal step-out will be evaluated later).
5. **Select** the Steering Data: *3 Steering BG background*.
6. **Give a name** (e.g. *DSMF* for Dip Steered Median Filter) and **Add as new**. Keep this attribute set window open.

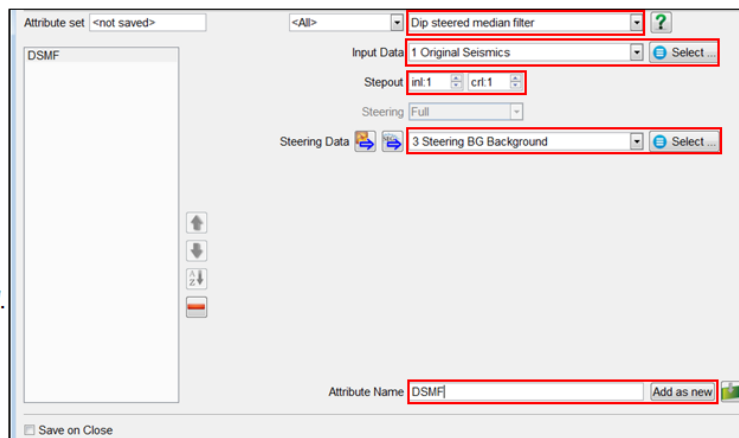

**Workflow cont'd:**

- Now in the scene, in the tree, **right-click** on In-line and choose Add and Select Data.

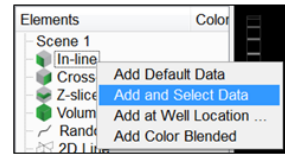

- Select** 1 Original Seismics from Stored tab and **press** OK.

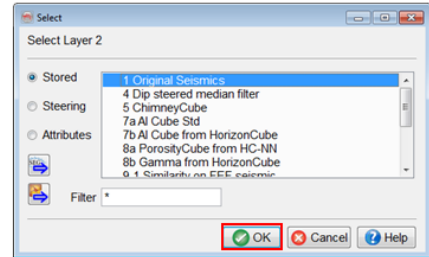

- In the tree, **right-click** on inline number (i.e. 425): Add > Attribute.

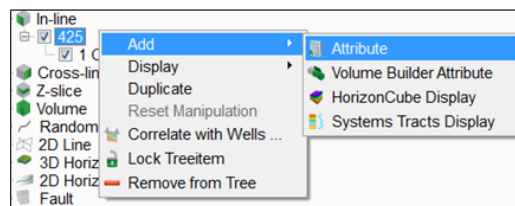

**Workflow cont'd:**

- Select** *DSMF* from Attributes tab.
- Go back** to the Attribute Set window and **click** the attribute evaluation tool icon to evaluate the step-out.
- Specify** Evaluate: Stepout.
- Set** the initial value "0-0", increment "1-1", and Nr of steps "5".
- Press** Calculate.

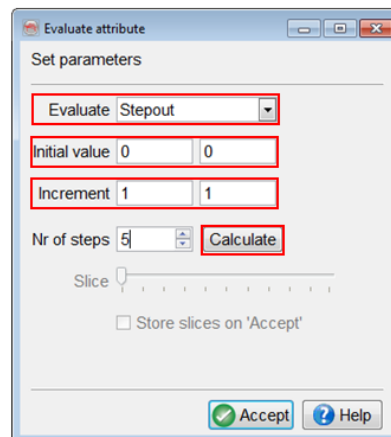
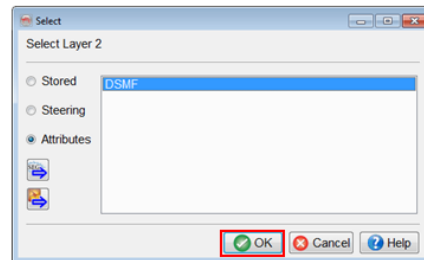

**Workflow cont'd:**

- 15. Once the computation is done, **move the slider** to change the stepout value and see the impact in the scene.
- 16. Assess which step-out is best (removing random noise, but not too much smearing)?  
Once chosen, **press Accept** and **close** the attribute set window.

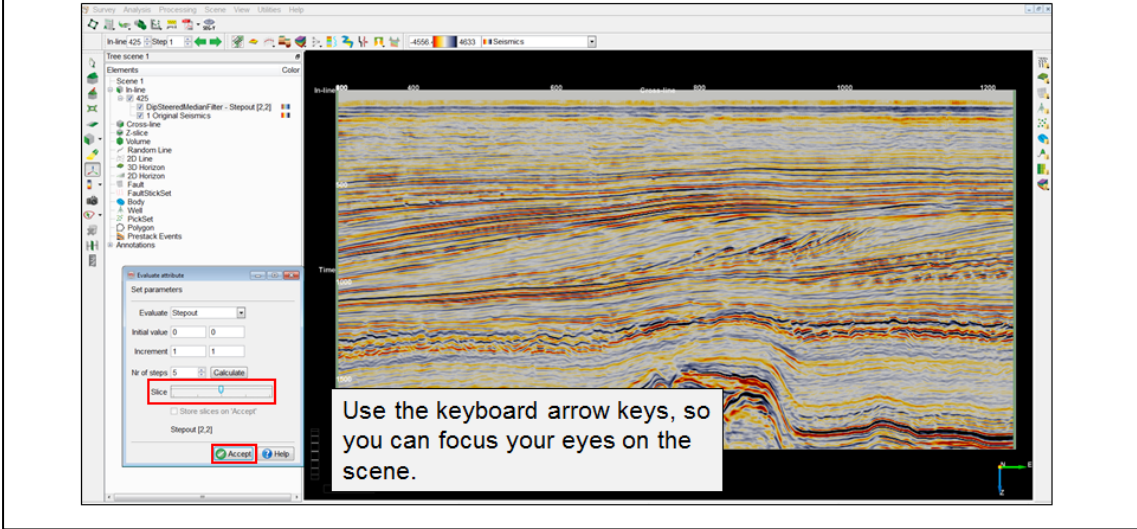

**Workflow cont'd:**

- 17. If you are satisfied with the parameters, you may want to process the attribute definition as a volume. **Follow:** Processing > Create Seismic output > Attributes > Single attribute > 3D or **click** on the 3D icon.

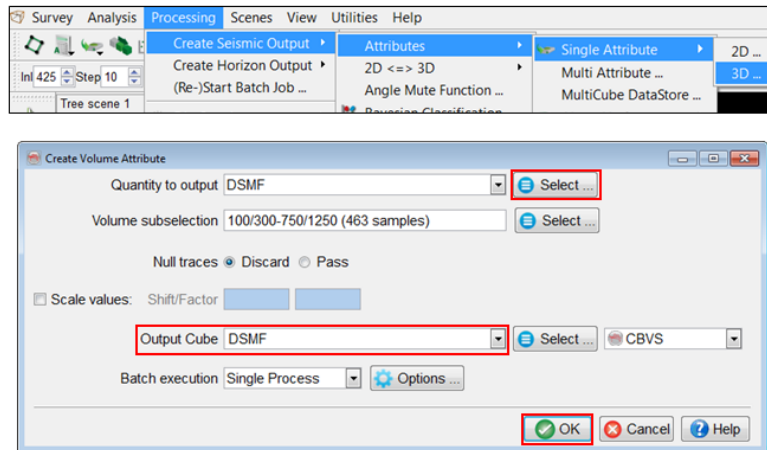

---



## 2.3.1f Dip-steered Diffusion Filter

Required licenses: OpendTect Pro, Dip-steering.

### Exercise objective:

Enhance low-quality seismic data near faults using a Dip-Steered Diffusion Filter.

### Workflow:

1. **Start** the attribute engine .
2. **Open** the Default Attribute set .
3. **Select** Dip-steered diffusion filter and **press** OK.

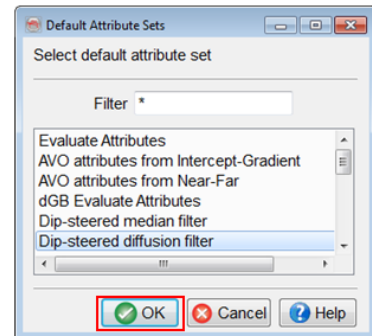

### Workflow cont'd:

4. In the pop-up window **set** 1 *Original Seismics* as input seismic and 3 *Steering BG Background* as input steering, and **press** OK.

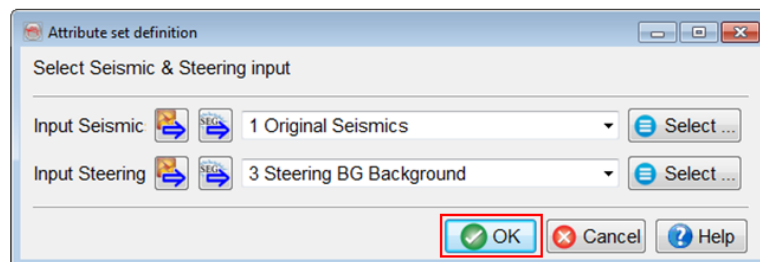

**Workflow cont'd:**

5. The attribute is defined.

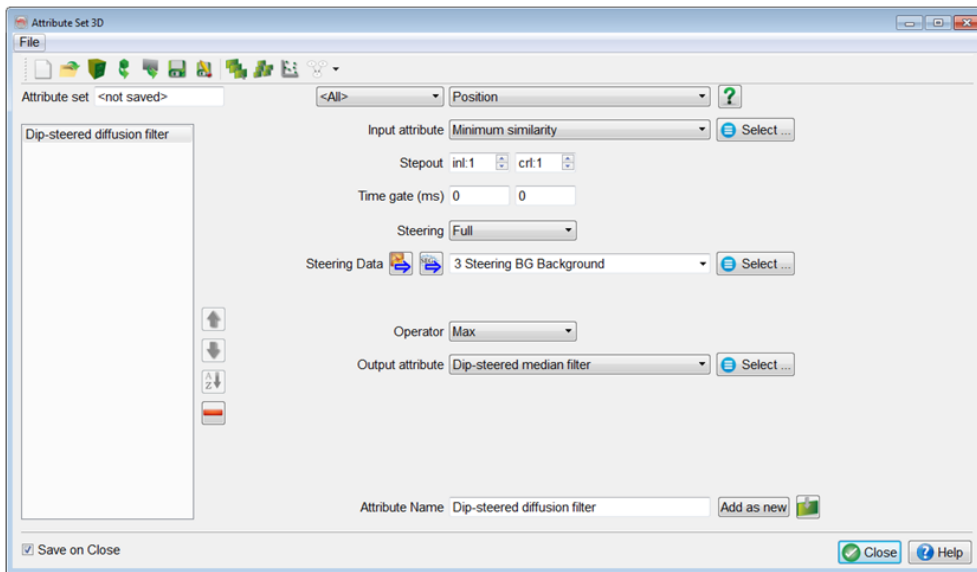

**Workflow cont'd:**

6. **Keep** the attribute set 3D window open and **add** the *Dip-steered diffusion filter* attribute in tree on inline 425.

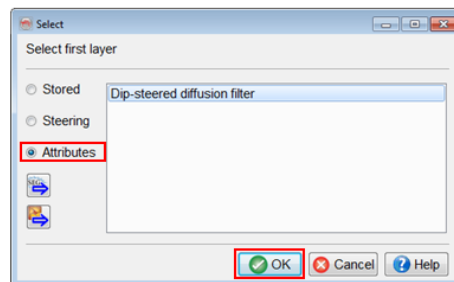
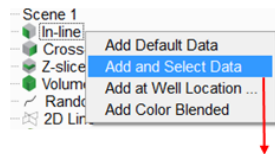

**Workflow cont'd:**

- Go back** to the attribute set 3D window, and **click** on the attribute evaluation icon  to evaluate the step-out of the *Dip-steered diffusion filter* attribute.
- Specify** Evaluate: Stepout
- Set** the initial value "0-0", increment "1-1", and Nr. of steps "5".
- Press** Calculate.

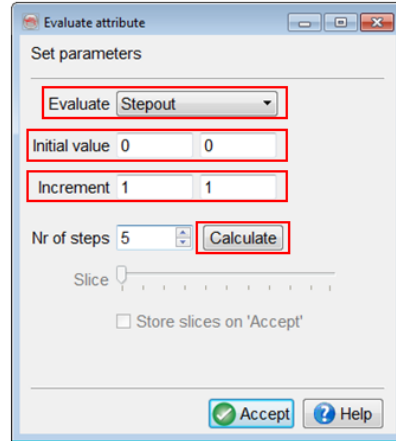

**Workflow cont'd:**

- Once the computation is done, **move the sliders** to change the stepout value and see the impact in the 3D scene.

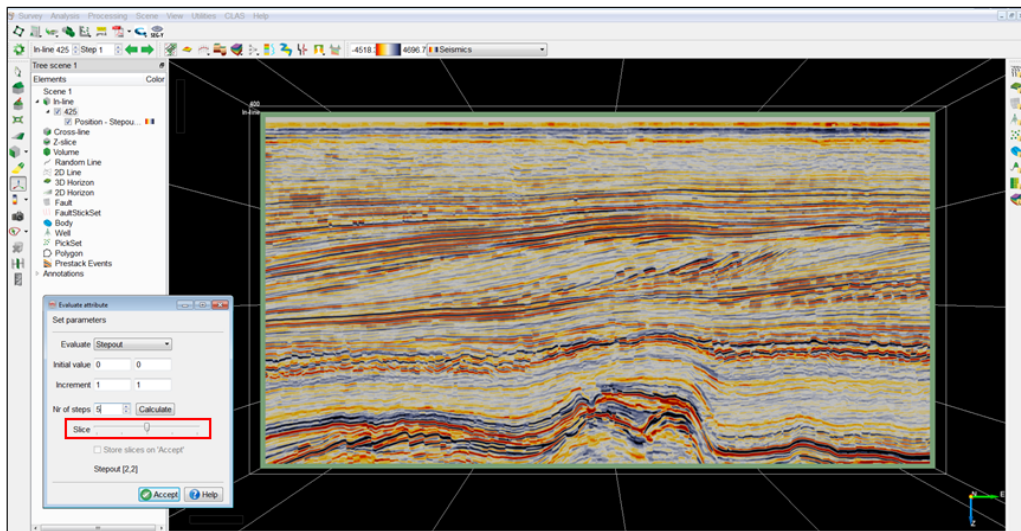

**Workflow cont'd:**

12. Evaluate which step-out is best (removing random noise without creating too many artefacts)? Once chosen, **press** Accept and **close** the attribute set window.

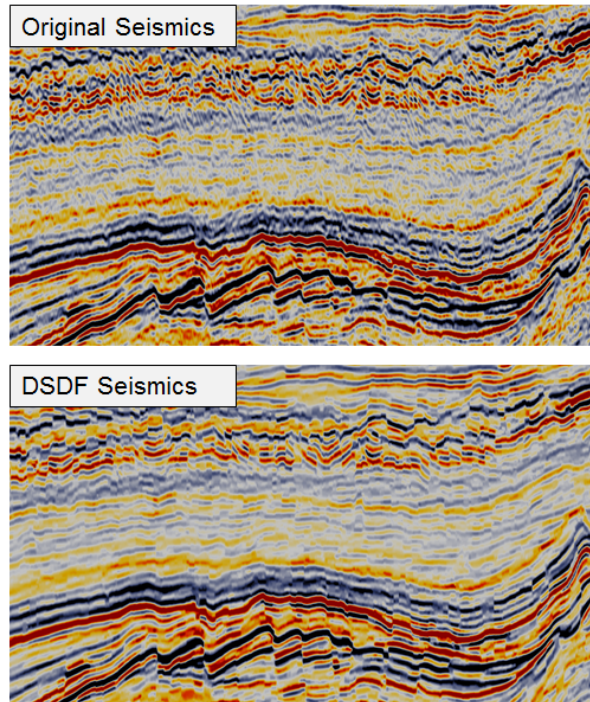
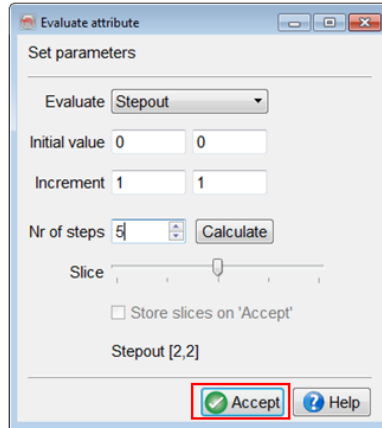



## 2.3.1g Dip-steered Fault Enhancement Filter

Required licenses: OpendTect Pro, Dip-steering.

### Exercise objective:

Remove noise and sharpen edges/faults with the Fault Enhancement Filter (FEF).

The Fault Enhancement Filter is a combination of dip-steered median filter and diffusion filter, modifying the seismic volume to enhance fault visibility.

Based on a similarity threshold, the data is smoothed (DSMF) away from the faults and sharpened (DSDF) at the fault location. The filter is released with the software as default attribute sets in two forms:

- *Fault Enhancement Filter*: All basic attributes needed as inputs for the filtering are shielded and the user can only control the amount of smoothing (dip-steered median filter) versus sharpening (dip-steered diffusion).
- *Fault Enhancement Filter (expert)*: The full attribute set definition is shown, which can be modified.

### Workflow:

1. **Start** the 3D attribute set window by clicking on .

2. **Click** on default attribute set icon .

3. Select Fault enhancement filter and **press** OK button.

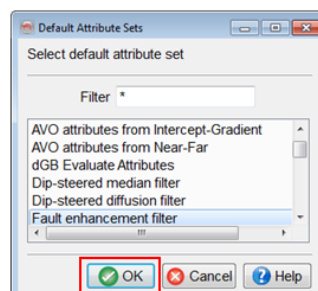
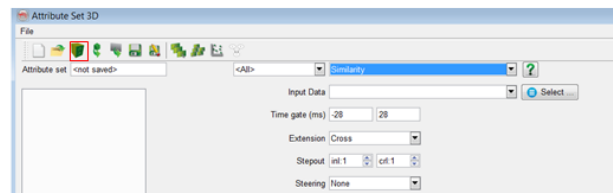

**Workflow cont'd:**

- Select** the 1 Original Seismics as input seismics and 3 Steering BG Background as input steering and **press** OK.

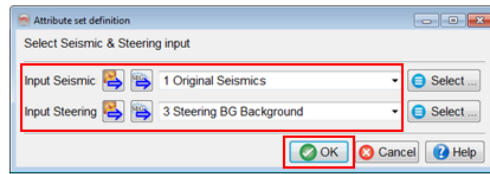

- This will create a fault enhancement filter attribute for you.
- Keep this window open and proceed to the next step.

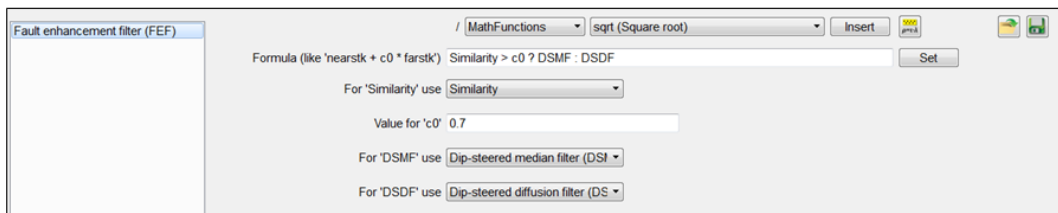

**Workflow cont'd:**

- Load** the default seismic data to a small area of the Z-slice at 1640 ms, between inlines 120-400 and crosslines 350-600.

- Right-click** on Z-slice in the tree to add stored 1 Original Seismics.

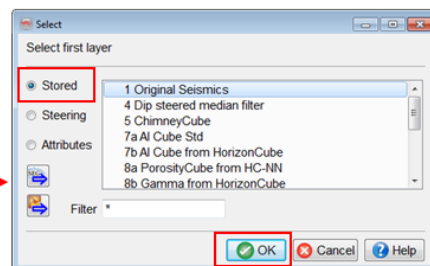
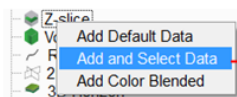

- Once it is loaded, again **Right-click** on Z-slice number 924 to change its position.

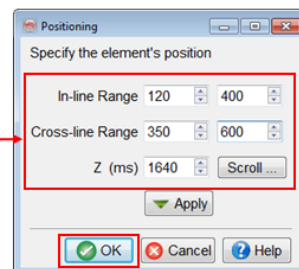
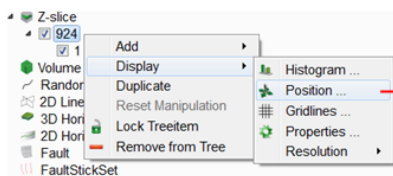

**Workflow cont'd:**

8. **Apply** the Fault Enhancement Filter to the constrained Z-slice at 1640 ms.

- **Right-click** on Z-slice number 1640 to **add** the *FEF* attribute.

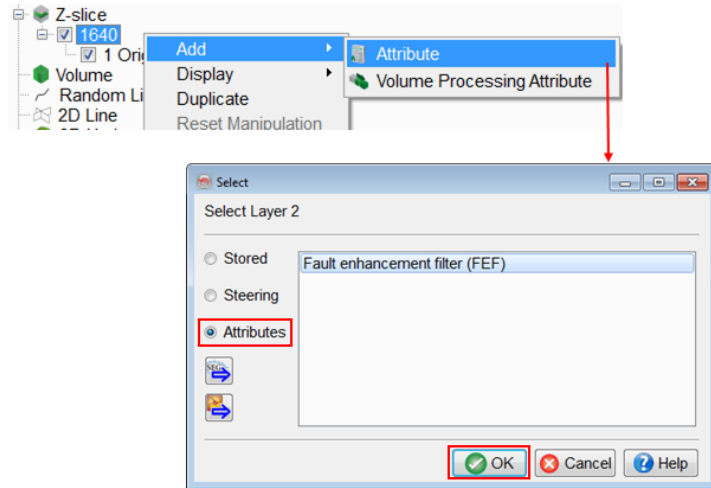

**Workflow cont'd:**

9. **Compare** 1 Original Seismics with the *FEF* attribute on the constrained Z-slice 1640 ms. Make sure to use the same colorbar range for both.

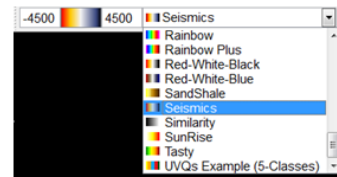

Did you get clear enough differences between original seismics and FEF?

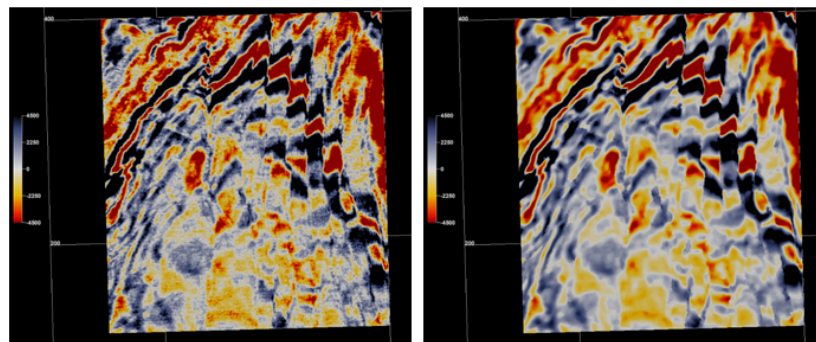

*Original Seismics (left) and FEF Seismics (right) displayed on Z-slice at 1640 ms.*

**Workflow cont'd:**

Evaluation of constant c0

A critical parameter of the Fault Enhancement Filter is c0. If the similarity value is higher than the c0 value, then the *Dip Steered Median Filtered Seismic* is used and otherwise the *Diffusion Filtered Seismic* is used.

10. **Go back** to the attribute set window, and **click** on the attribute evaluation icon  to evaluate the constant c0.

11. **Use** Initial value: 0.1, Increment: 0.1, Nr. of steps: 9 and **press** calculate.

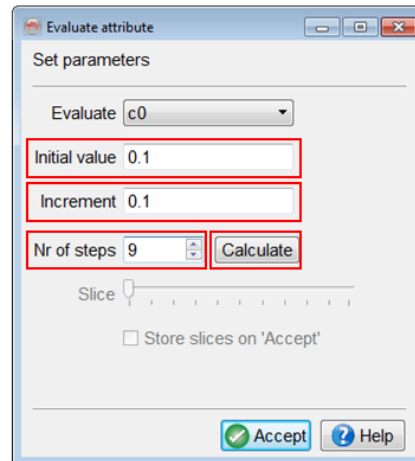

**Workflow cont'd:**

Evaluation of constant c0

12. **Move** the slider to assess which constant shows the best results (more faults visible and less noise)? **Press** accept to save the constant c0.

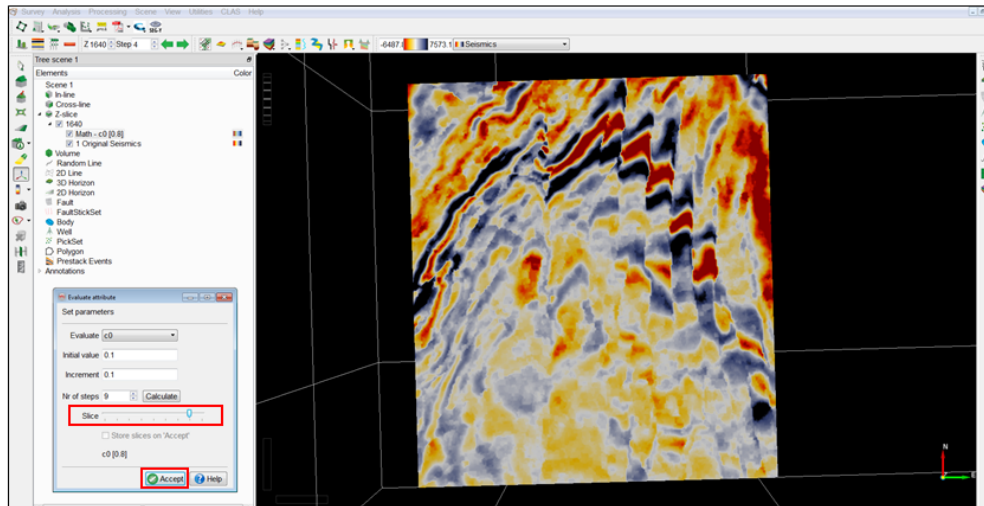

**Workflow cont'd:**

Fault Enhanced Similarity

13. **Open** the Attribute set window and **create** a new dip-steered similarity attribute using the *FEF* attribute as input. **Use** the default values for rest of the parameters. **Name** it *FEF\_Similarity* and **Add as new**.

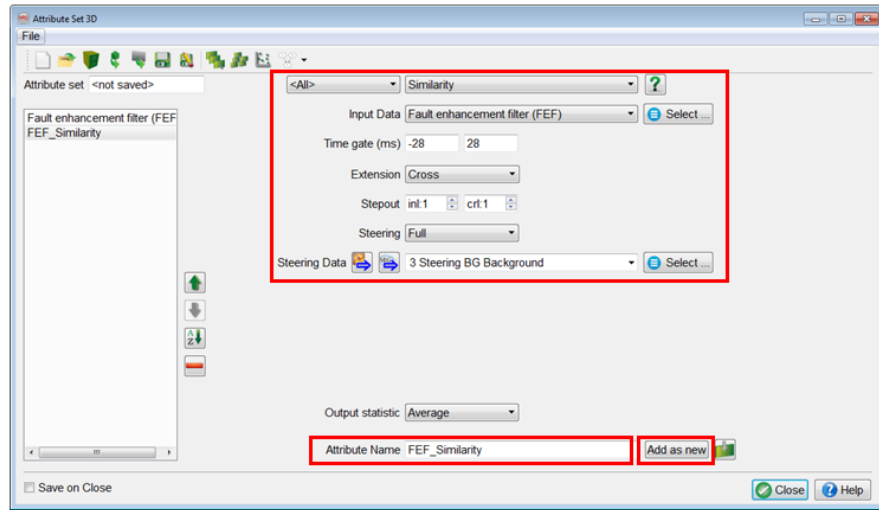

**Workflow cont'd:**

Fault Enhanced Similarity

14. **Create** yet another dip-steered similarity attribute using the *1 Original Seismics* as input. **Use** the same parameters as the previous step. **Name** it *FS\_Similarity* and **Add as new**.

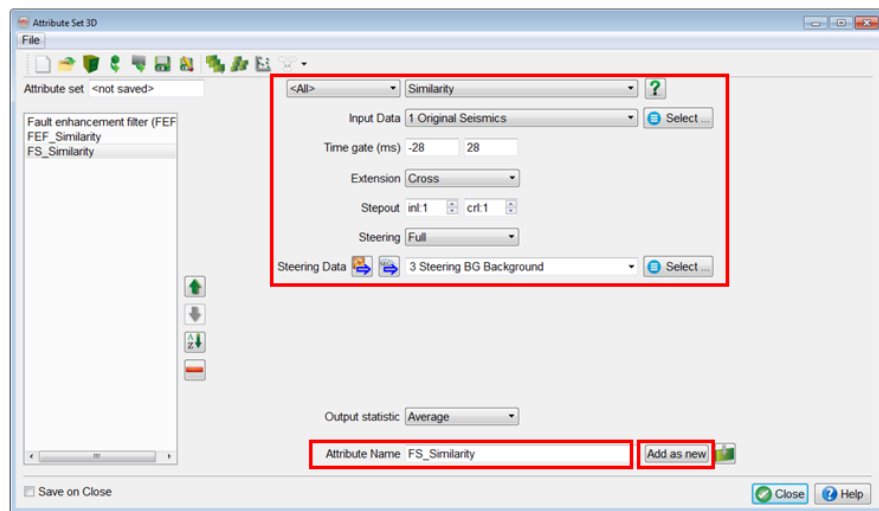

**Workflow cont'd:**

Fault Enhanced Similarity

15. **Apply** one-by-one the *FS\_Similarity* (calculated using original seismic) and the *FEF\_Similarity* (based on the Fault Enhancement Filtered seismic) to the constrained Z-slice at 1640 ms.

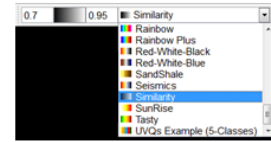
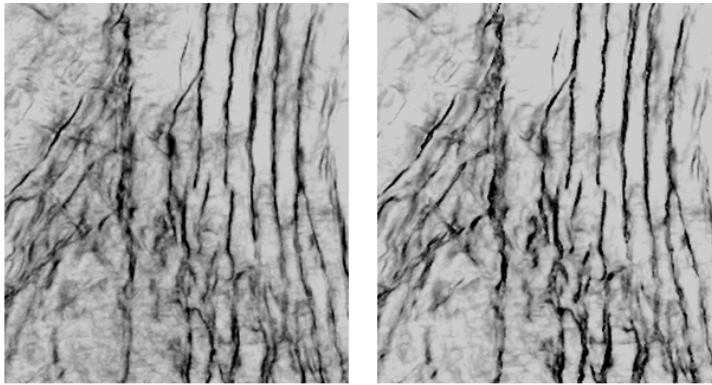

Don't forget to use identical *Similarity* colorbars!

*Dip-steered similarity from Original Seismics (left) and FEF Seismics (right)*

**Tip:** Both *Fault Enhancement Filter* and *Fault Enhancement Filter (expert)* can be accessed from the 'Default Attribute Set' using the Drawer  icon from the row of icons at the top.

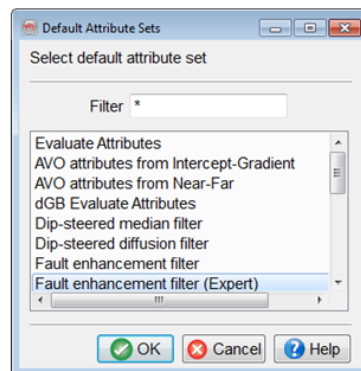

## 2.3.3a Ridge Enhancement Filter

Required licenses: *OpendTect*.

### Exercise objective:

Compute the Ridge-enhancement filter attribute for improved fault visualizations.

### Workflow:

1. **Start** the 3D attribute engine: Analysis > Attributes > 3D.

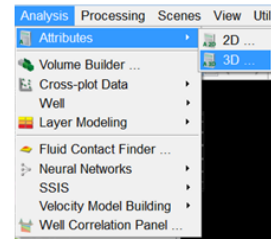

### Workflow cont'd:

2. **Open** the default attribute set .
3. **Select** Ridge Enhancement filter (Expert).
4. **Press** OK.

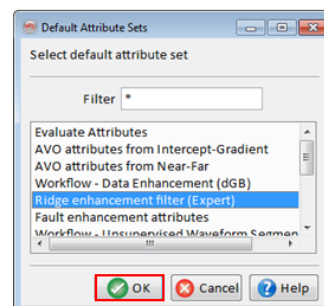

5. **Select** 4 Dip steered median filter for Input seismic and 3 Steering BG Background for Input Steering.

6. **Press** OK.

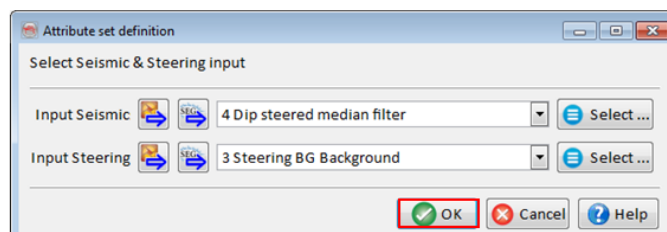

**Workflow cont'd:**

7. **Keep** everything default with the default name *Ridge enhancement filter*.
8. **Uncheck** Save on close and then **Close** the window.

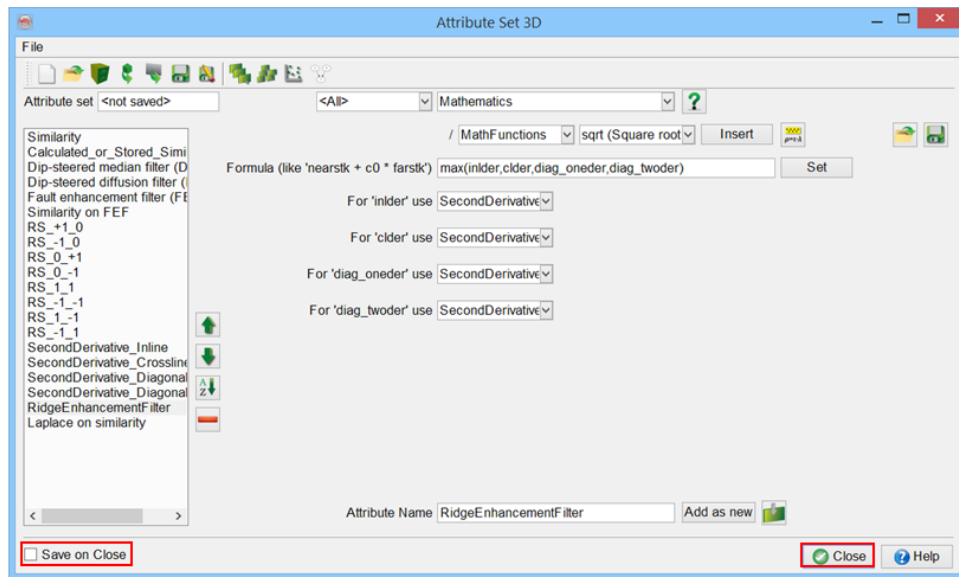

**Workflow cont'd:**

9. **Right-click** on Z-slice in the tree > Add and Select Data.
10. As visualization of the full z-slice will take some time, we will limit the inline and crossline ranges. So, **press** Cancel in the pop-up window.

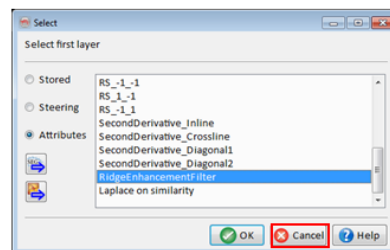
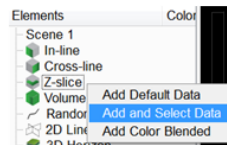

11. **Right-click** on the Z-slice number > Display > Position.

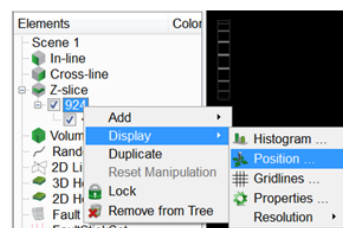



**Workflow cont'd:**

12. **Load** Z slice 1640ms between inlines 120-400 and crosslines 350-600.

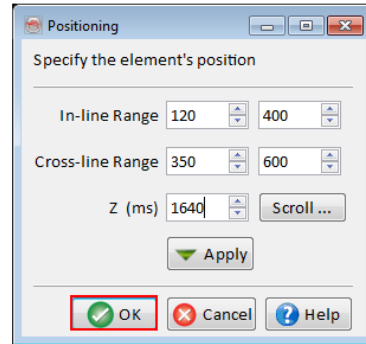

13. In the pop-up window **select Ridge enhancement filter** from Attributes.

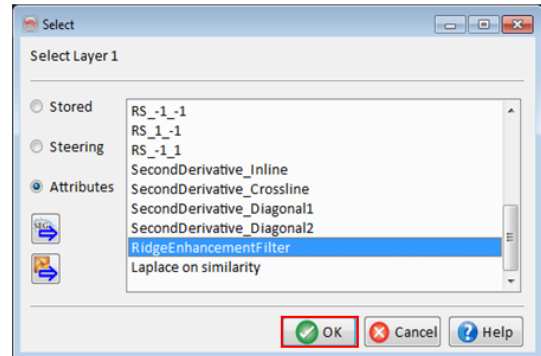

14. **Press** OK to display it in the scene.

**Workflow cont'd:**

15. Once the slice is displayed, **click** on its attribute in the tree to activate it and **change** the color bar to Grey scales.

16. The result should be similar to the one shown below. Compare it with the attributes of the previous exercise.

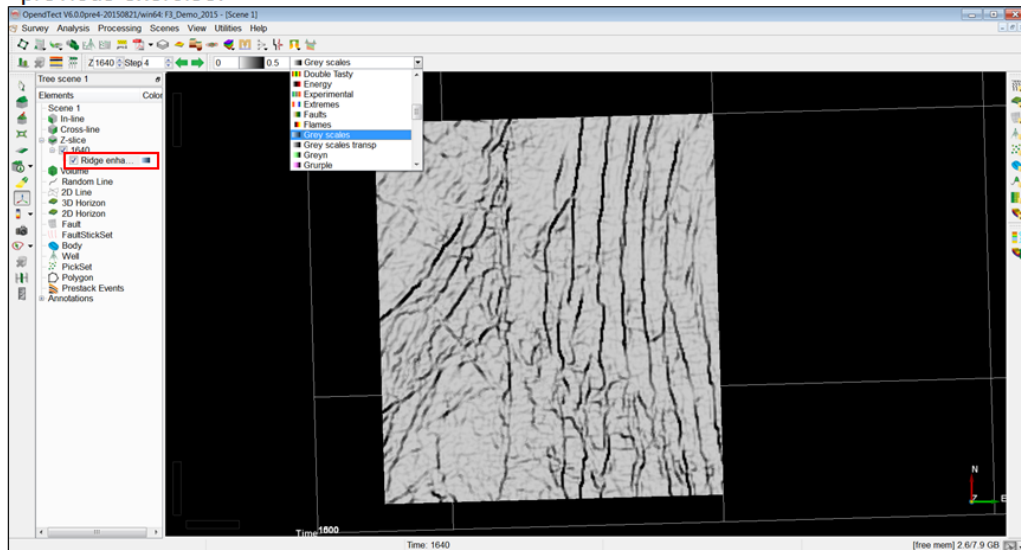

## 2.3.4a Spectral Blueing

Required licenses: OpendTect Pro, Seismic Spectral Blueing.

### Exercise objective:

Increase the vertical resolution of the seismic data with Seismic Spectral Blueing (SSB) technique.

### Workflow:

1. **Go** to the Attribute engine: Analysis > Attributes > 3D or **click** on the  icon > 3D.
2. **Choose** Spectral Blueing attribute from the drop-down list.
3. **Select** 1 Original Seismics as Input Data.
4. **Keep** the default Single Operator option selected.
5. **Click** Analyze and Create ... to launch the SSB Module.

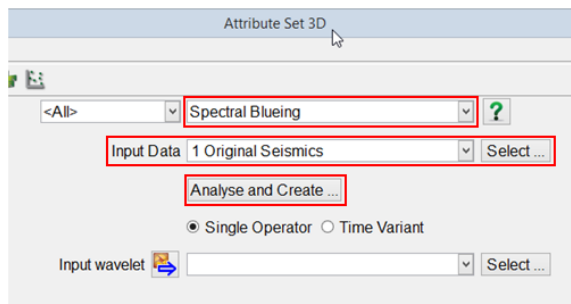
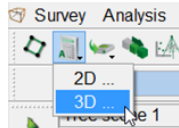

### Workflow cont'd:

In order to design an SSB operator, it is mandatory to analyze the seismic and well data spectra by loading some seismic traces and time converted acoustic impedance well logs.

6. **Click** on the  icon to pop up the Select Input Data window.
7. **Keep** 1 Original Seismics as selected seismic.
8. **Click** Load Seismic to load 40 random traces from the selected seismic.
9. **Keep** the default Sub option for Time Range and **enter** 500 (Start) and 1500 (End).

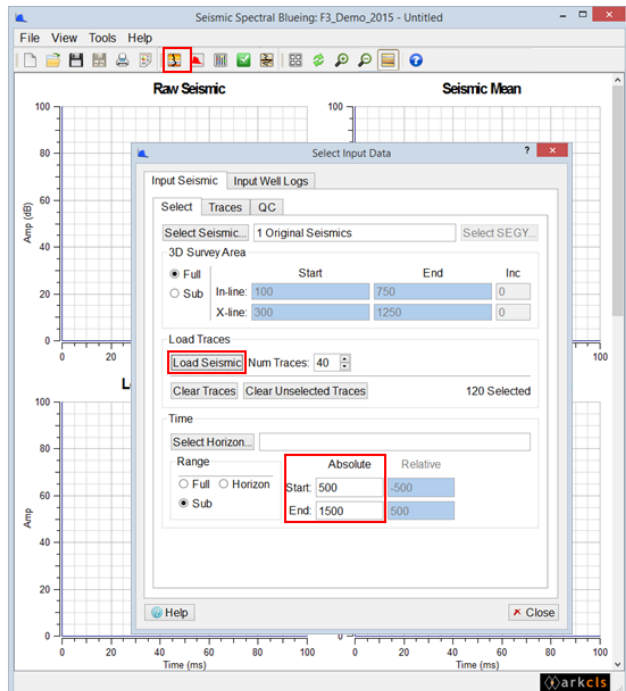

**Workflow cont'd:**

10. **Switch** to Input Well Logs tab.
11. **Click** Load wells.
12. **Select** the well *F3-04* and the *P-Impedance* log.
13. **Keep** the default Sub option for Time Range and **enter** 500 (Start) and 1500 (End).
14. **Close** the Select Input Data window.

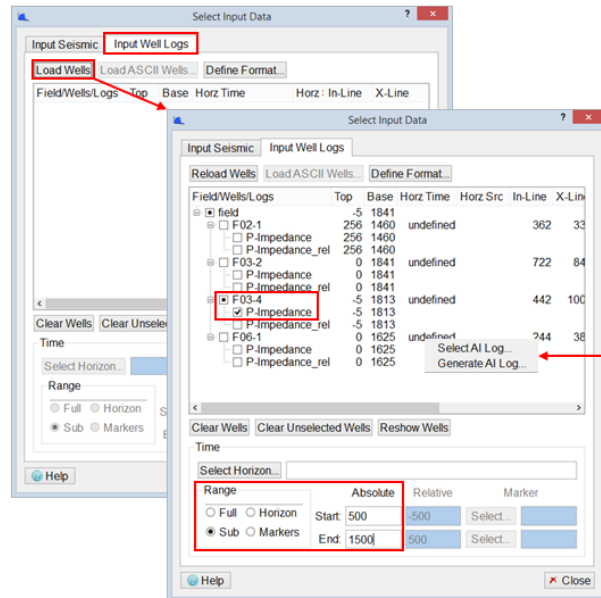

Right-click on a well either to select another or to generate a new acoustic impedance log if it is not available.

**Workflow cont'd:**

15. Once the seismic and well data are loaded, you can see various curves displayed in different plots. **Take** your time to scroll through this window: **left-click** on any curve and in the lower left corner find out what does it represent.
16. **Right-click** on any plot to see a menu that allows to change various display options, show a legend, etc.

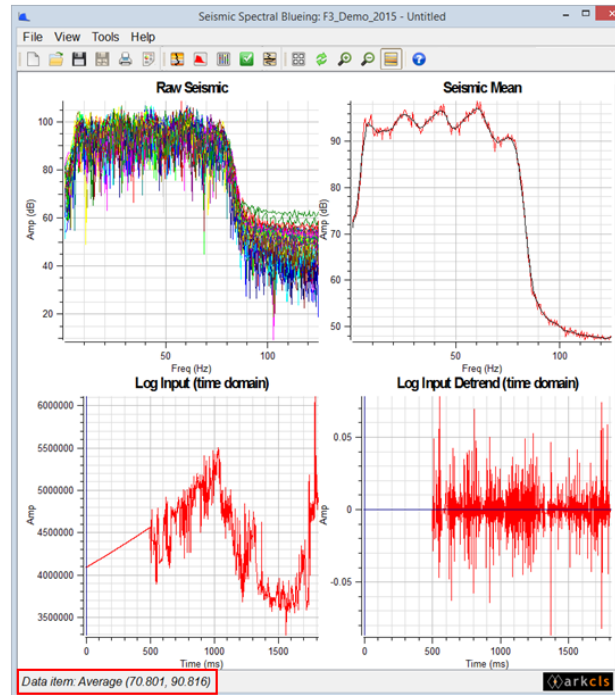
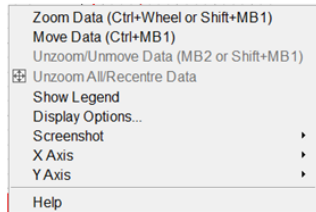

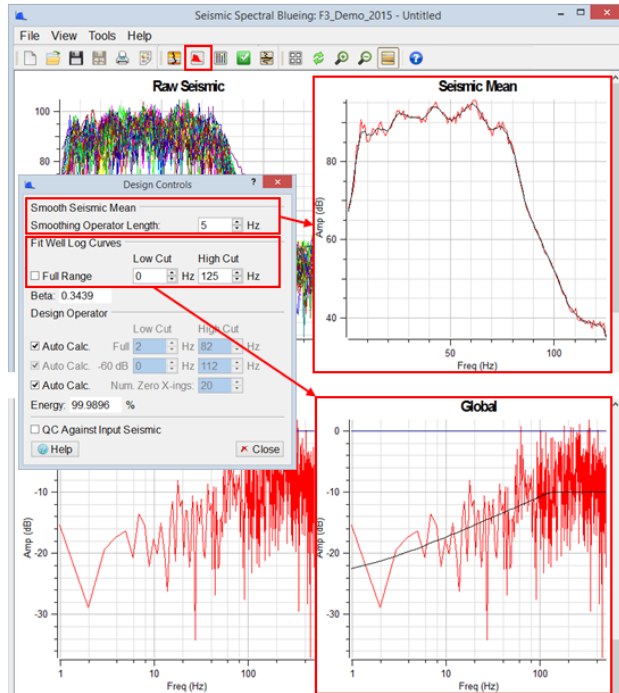

**Workflow cont'd:**

17. **Click** on  to pop up the Design Controls dialog.
18. **Smooth** the average amplitude-frequency spectrum of seismic data displayed on the Seismic Mean plot.
19. **Uncheck** the Full Range option for Fit Well Log Curves and **enter** 125 Hz as the High Cut frequency, thus limiting it to the Nyquist frequency of input seismic.
20. **Observe** changes on the Global plot.



**Workflow cont'd:**

21. **Tweak** the Low and High Cut parameters of the Design Operator such that the residual operator (blue curve on the Residual Operator QC plot) stays 0 in the frequency domain, with a quick drop on both sides.
22. **Save** the operator  by giving it a name. This operator is saved as a wavelet.
23. **Save**  your session (optional).

The SSB operator is stored as a wavelet and can be visualize in the wavelet manager.

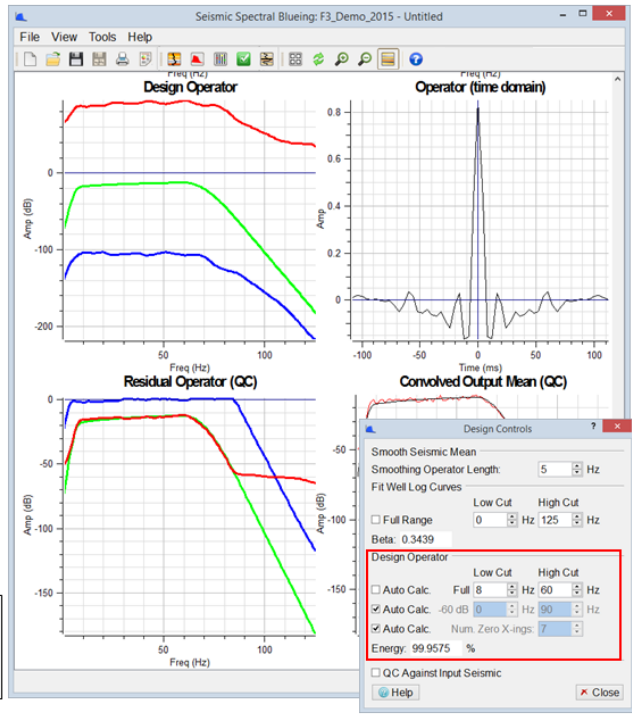

**Workflow cont'd:**

The effect of the parameter tweaking of the Design Operator is immediately visible in View Seismic window which can be popped up by clicking on  and is updated automatically.

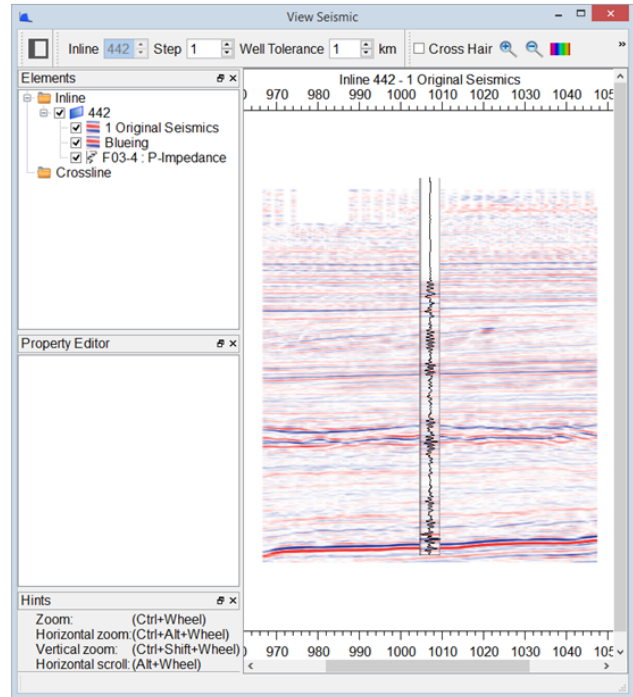

**Workflow cont'd:**

- 24. **Close** the SSB module and **return** to the Attribute Set 3D window.
- 25. **Check** if the newly-saved operator is selected.
- 26. **Specify** the Attribute Name and **Click** Add as new.

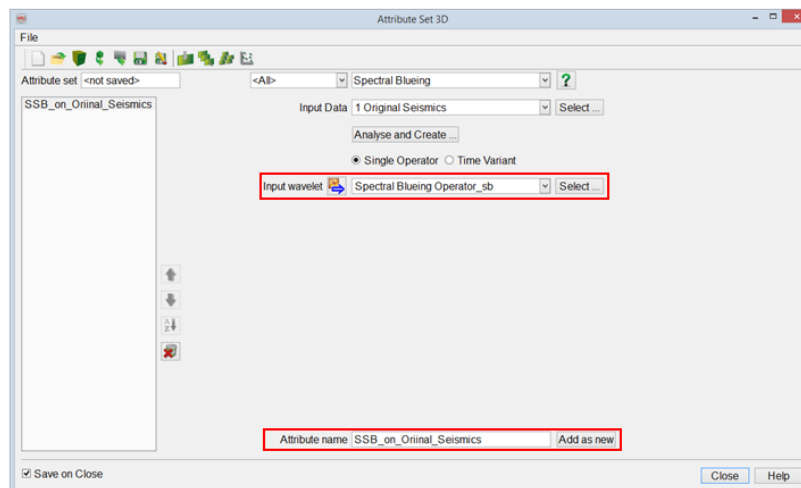

**Workflow cont'd:**

27. **Right-click** on In-line in the tree and **chose** Add and Select Data.

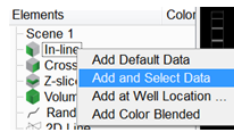

28. **Select** 1 Original Seismics from Stored tab and **press** OK.

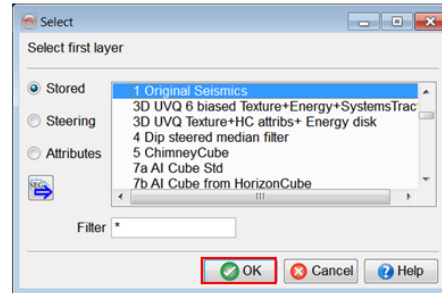

**Workflow cont'd:**

29. **Apply** the SSB attribute on inline 425 and **compare** the result to the original seismic data: **Right-click** on In-line 425 in the tree and **follow** Add > Attribute.

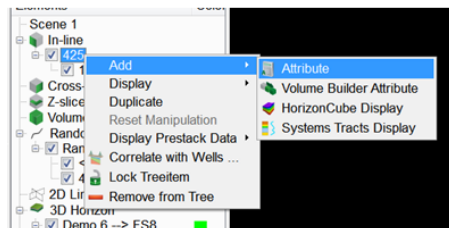

30. **Select** SSB\_on\_Original\_Seismics from Attributes tab and **press** OK.

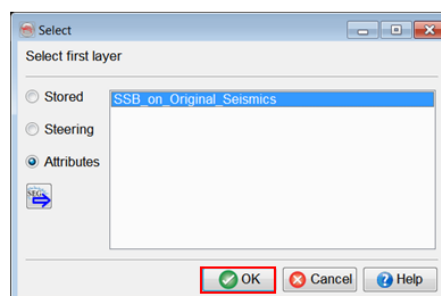

---

**Workflow cont'd:**

30. The results should be similar to the ones shown below.

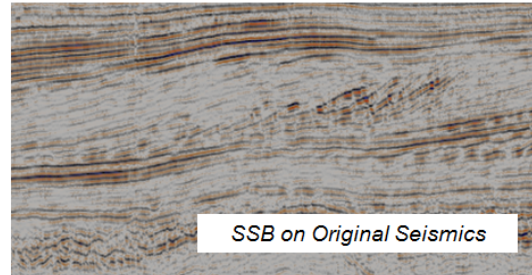
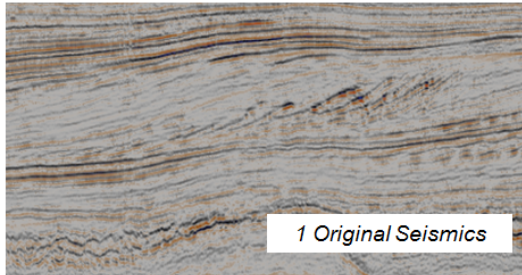

31. **Compare** the original seismic and the SSB seismic: **tick on** and **off** the overlaying attribute in the tree.

## 2.3.5a Optical Stacking

Required licenses: OpendTect.

### Exercise objective:

Enhance the amplitude anomaly on a random line with optical stacking.

### Workflow:

1. **Right-click** on 3D Horizon in the tree > Add... and **select** Demo 6 --> FS8.
2. **Launch** the Attribute Set 3D window.
3. **Choose** Volume statistics attribute from the drop-down list.
4. **Specify** parameters as shown on the image to define an RMS amplitude **give** it a name and **press** Add as new.

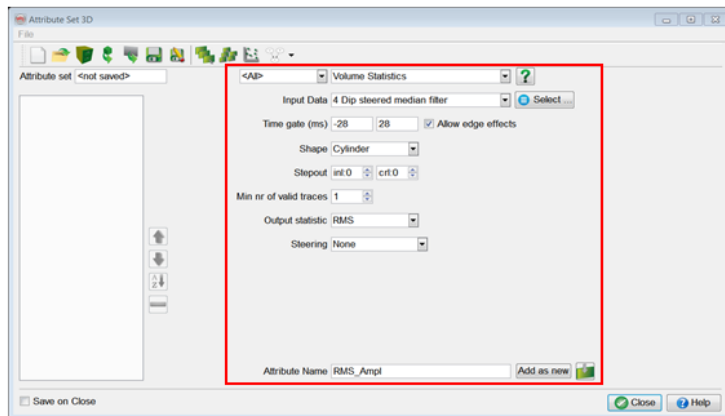
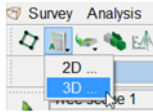
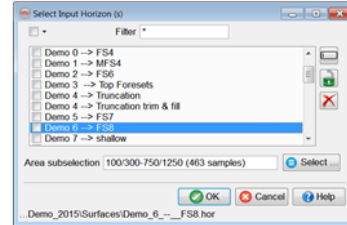
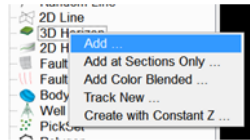

### Workflow cont'd:

5. **Right-click** on Demo 6 --> FS8 > Add > Attribute.
6. **Choose** the RMS amplitude and **click** OK. Optionally, change the color bar for RMS amplitude to Rainbow Plus.
7. **Right-click** on Random Line in the tree > New > Interactive ...

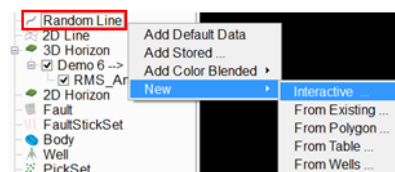
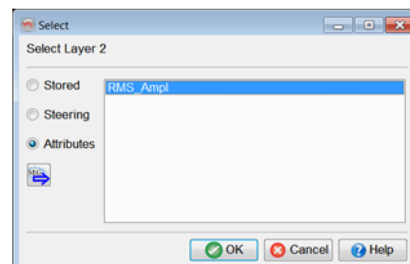
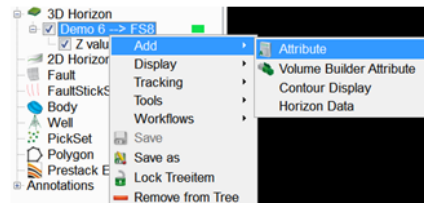



**Workflow cont'd:**

- Pick** a random line going through the structure where the amplitude anomaly is seen. Using the left mouse button, click on the map to insert a node.

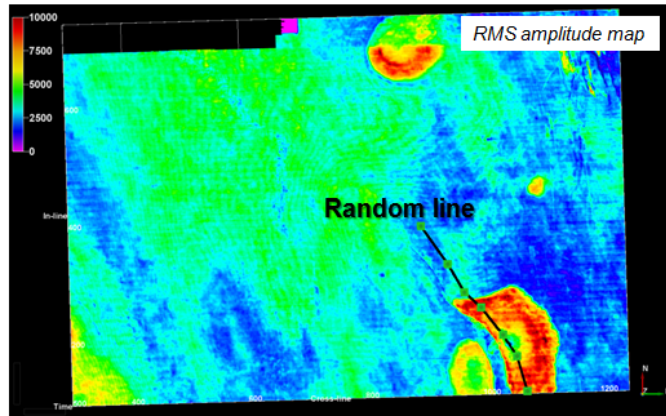

- Right-click** on a newly picked random line in the tree > **Save as ...** and type in a new name.

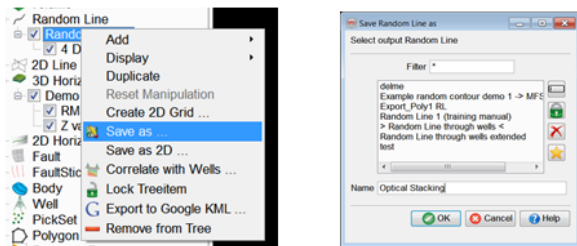

**Workflow cont'd:**

- Launch** the Attribute Set 3D window.

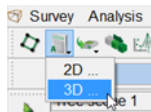

- Choose** Volume statistics attribute from the drop-down list.

- Specify** the following parameters to define an optical stack: *4 Dip steered median filter* as Input Data, [0, 0] Time gate, Optical stack Shape, Stack stepout of 15, Full Steering by 3 *Steering BG Background*.

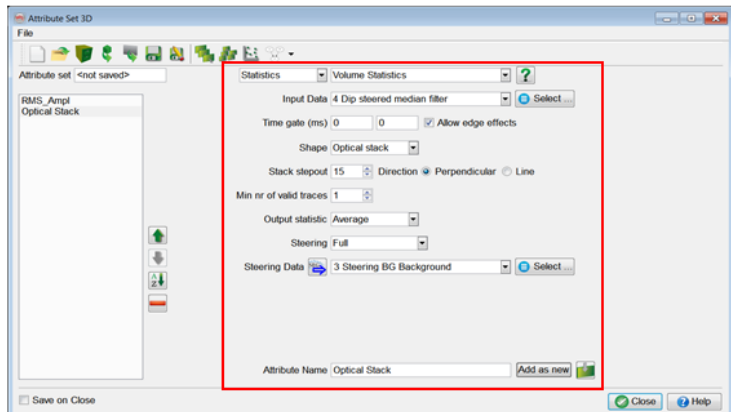

Stack stepout of 15 is equal to 375m at the bin size of 25m.

**Workflow cont'd:**

13. **Right-click** on the random line in the tree > Add > Attribute

14. **Choose** the optical stack attribute from the Attributes list and **click** OK.

15. Optionally **evaluate** the Stack stepout parameter.

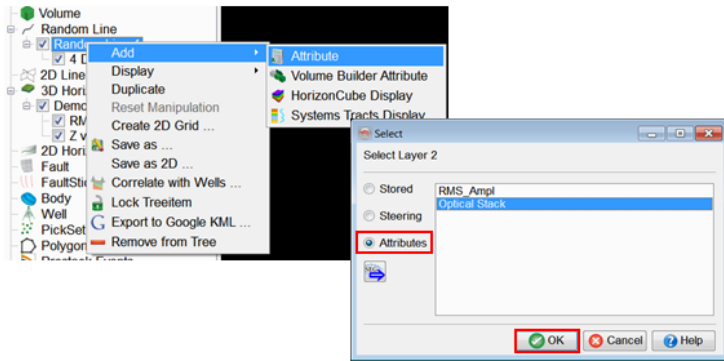

Compare the optical stack attribute to the input seismic data.  
Discuss the results: What events have been preserved, what events have been enhanced, why?

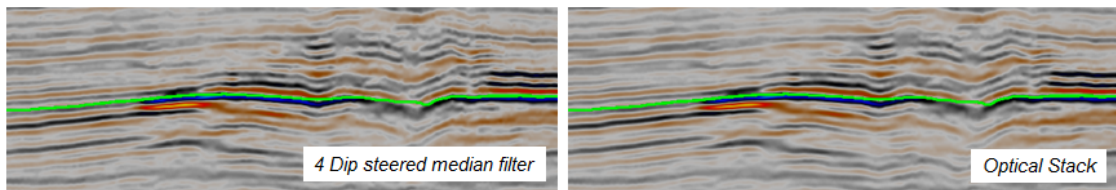

## 2.3.5b Seismic Feature Enhancement

Required licenses: OpendTect Pro, Spectral Feature Enhancement.

### Exercise objective:

Enhance the amplitude anomaly on a random line with Seismic Feature Enhancement (SFE).

### Workflow:

1. **Go to** Analysis > ARK CLS Utilities > Seismic Feature Enhancement.
2. **Keep** all the SFE windows open and go to the OpendTect main window.
3. **Right-click** on Random line in the tree > Add Stored ....
4. **Choose** the random line created in the previous exercise 2.3.5a and **click** OK.

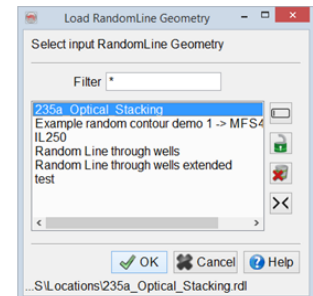
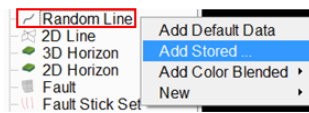
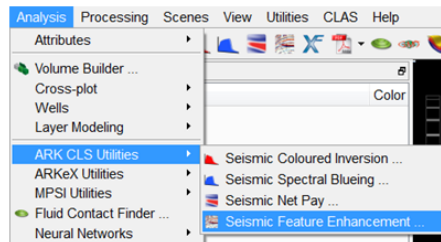

### Workflow cont'd:

5. **Right-click** on the random line name in the tree > Display > Position.
6. **Keep** the Random lines window open. This window lists In-line and Cross-line positions of all nodes of the selected random line. You will need this information in one of the next steps.

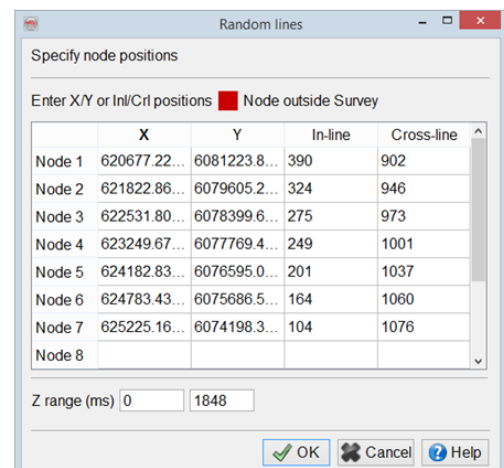
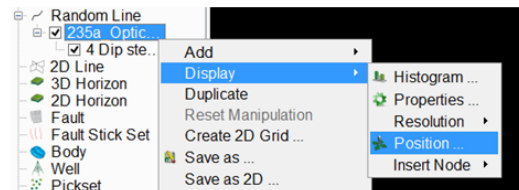

**Workflow cont'd:**

7. **Go** back to the SFE main window and **Click** on Select Data icon .
8. **Click** on Input Volume in the Select Data window
9. **Choose** 4 Dip steered median filter in Select Volume window and **click** Select.
10. **Click** on Output Volume in the Select Data window.
11. **Enter** a new name of the output dataset and **click** Select.

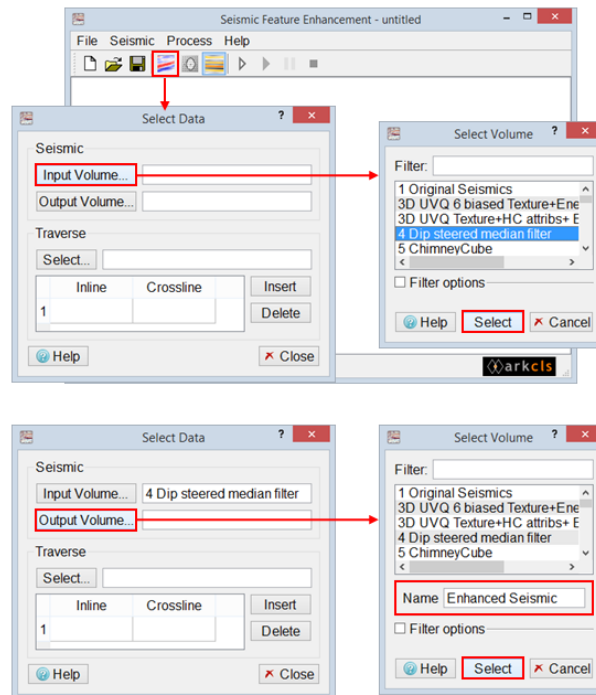

**Workflow cont'd:**

12. **Enter** manually the random line node positions in the Traverse section from Step 6.

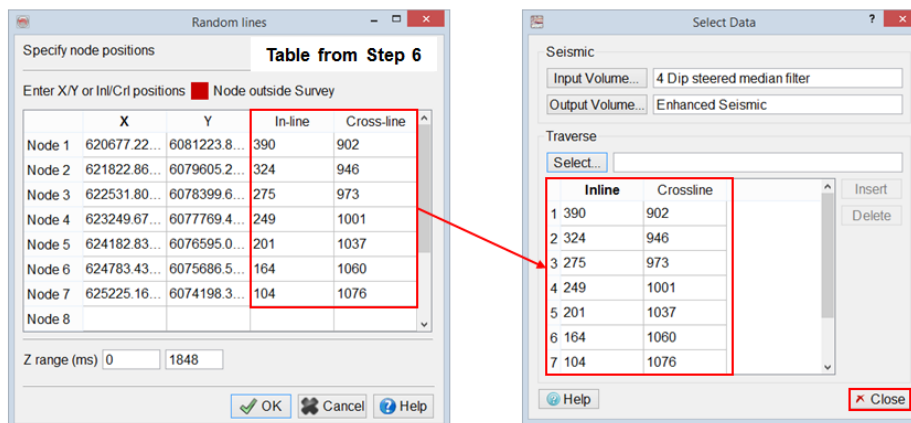

13. **Close** the Select Data window.
14. **Close** the Random lines window.

Alternatively, digitize the random line by picking a polygon that you can select as input for Traverse by clicking on Select button.



**Workflow cont'd:**

15. **Click** on Aperture Design icon  in the main SFE window.
16. **Enter** 375 m and 75 m as Traverse normal and parallel aperture sizes.
17. **Close** the Aperture Design window.

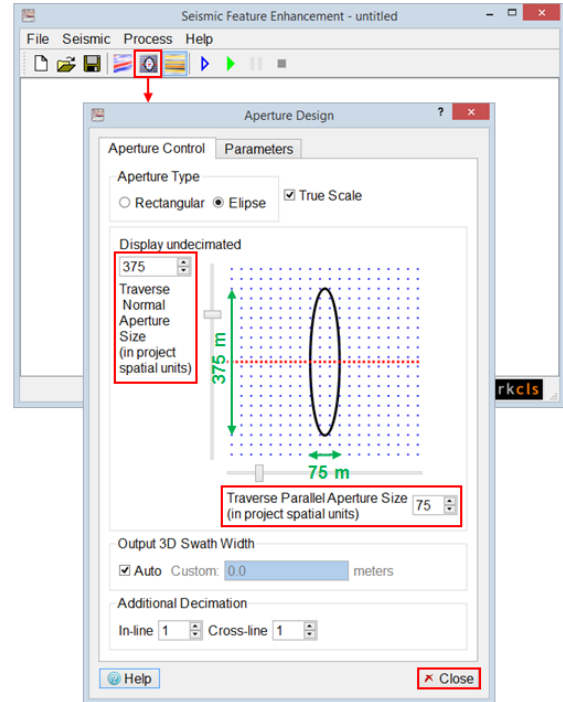
All traces inside the ellipse are stacked and the result is output at the center of ellipse.



**Workflow cont'd:**

18. **Preview** SFE results by clicking on  icon in the main SFE window.
19. **Display Seismic** by clicking on  icon if it is not displayed yet.

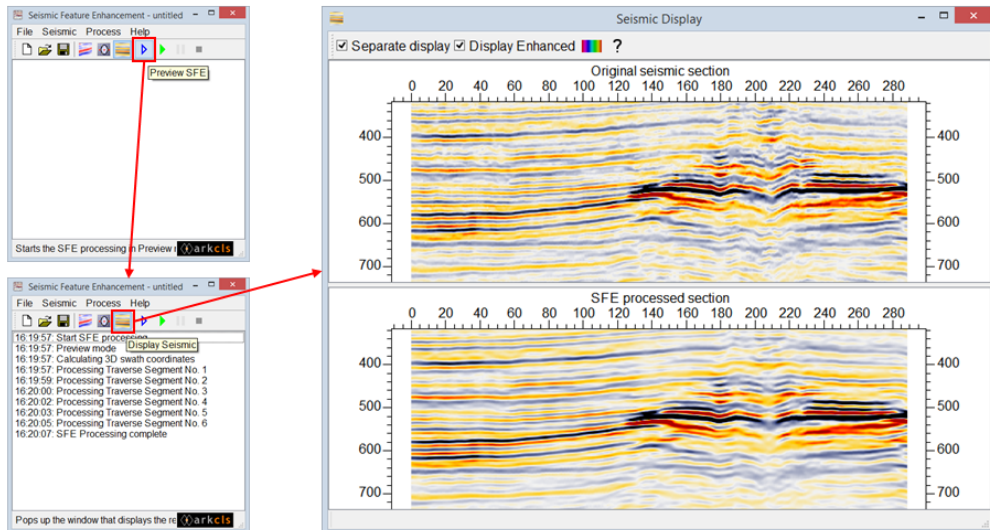

**Workflow cont'd:**

20. **Start Processing** by clicking on  icon in the main SFE window.

21. **Click Overwrite** to output SFE results along the traverse.

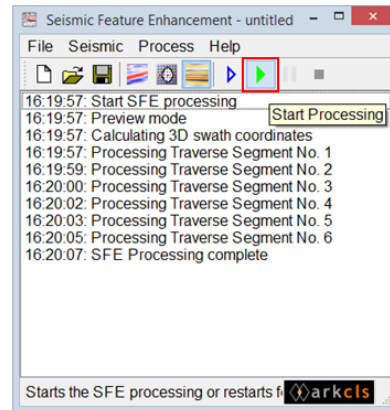
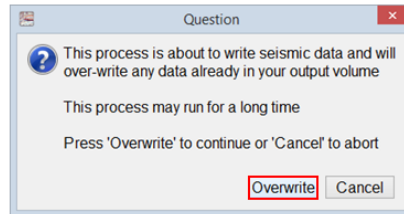

22. Optionally, **follow File > Save As ...** to save your session.

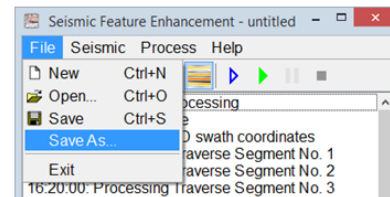

## 2.3.5c Fluid Contact Finder

Required licenses: OpendTect Pro, Fluid Contact Finder.

### Exercise objective:

Enhance the amplitude anomaly associated with a structure with Fluid Contact Finder (FCF).

### Workflow:

1. **Right-click** on 3D Horizon in the tree > Add ...
2. **Select** Demo 6 --> FS8 and **click** OK.

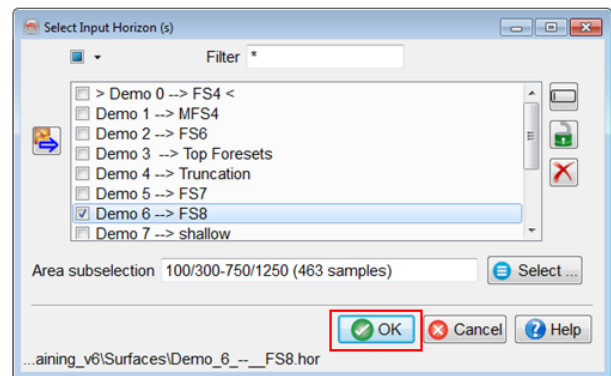
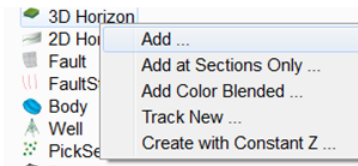

### Workflow cont'd:

3. **Open** the attribute window .
4. **Choose** Similarity attribute from the drop-down list and **Select** 4 Dip steered median filter data as input.
5. **Set** the time-gate to [-12, 12] ms.

6. **Select** Steering as Full and **use** 3 Steering BG Background.

7. **Specify** Output statistics: Min.

8. **Name** the attribute *Min Sim* and **Add as new**.

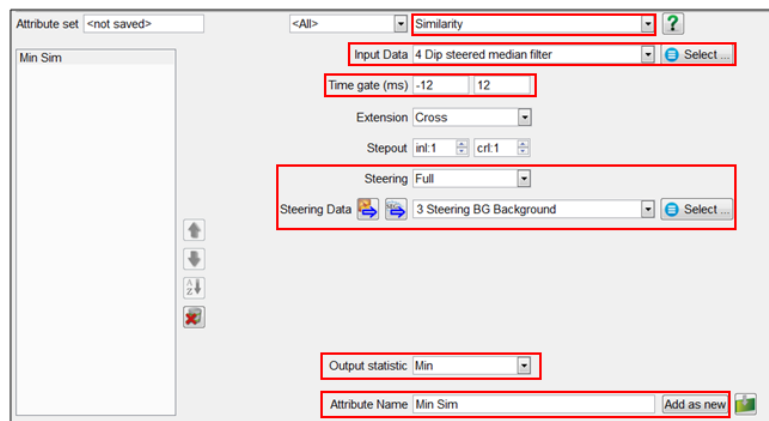

**Workflow cont'd:**

9. **Display** the attribute on *Demo 6* --> *FS8* by **right-clicking** on Z values in the tree > Select Attribute > Attributes > Min Sim.

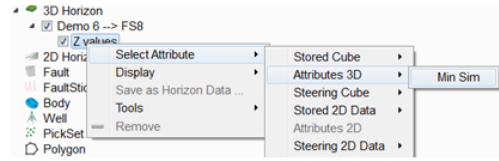

**Workflow cont'd:**

10. Create a new polygon by **right-clicking** on Polygon in the tree > New.

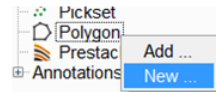

11. **Name** the new polygon: *Bright Spot*.

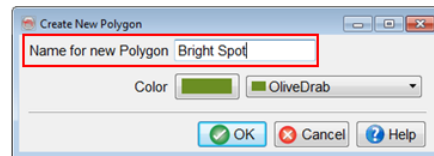

12. **Draw** the polygon using left-click, as shown in the image.

13. **Right-click** on the polygon in the tree (or in the scene) > **Close Polygon**.

14. **Right-click** on the polygon in the tree > **Save**.

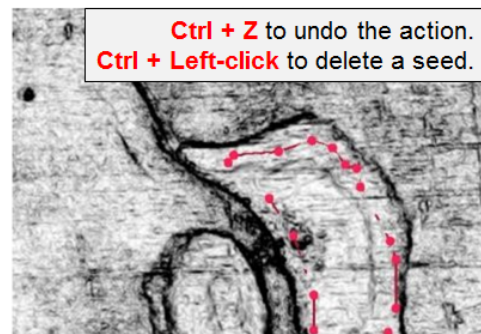
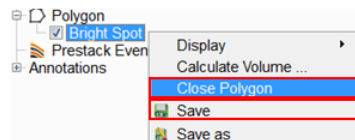



**Workflow cont'd:**

- 15. **Go** to Analysis > Fluid Contact Finder (or click on the  icon).
- 16. **Select** the *Demo 6 --> FS8* horizon, leave the default Input Cube *4 Dip steered median filter*.
- 17. **Click** on Select for Volume subselection and **choose** Bright Spot polygon created earlier.

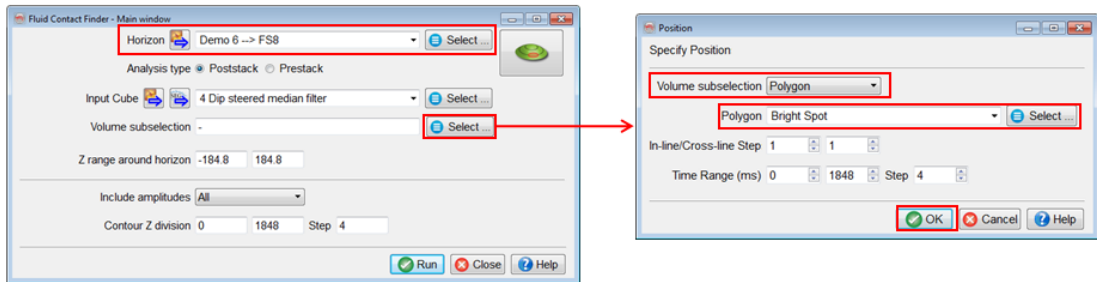
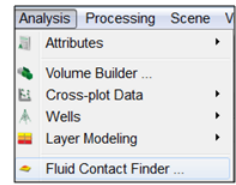

**Workflow cont'd:**

For the first test, contour Z division as the entire Z range of the survey. This can be restricted later. Also leave the Z range around horizon as default.

- 18. **Click** Run to start the extraction and clustering of the data

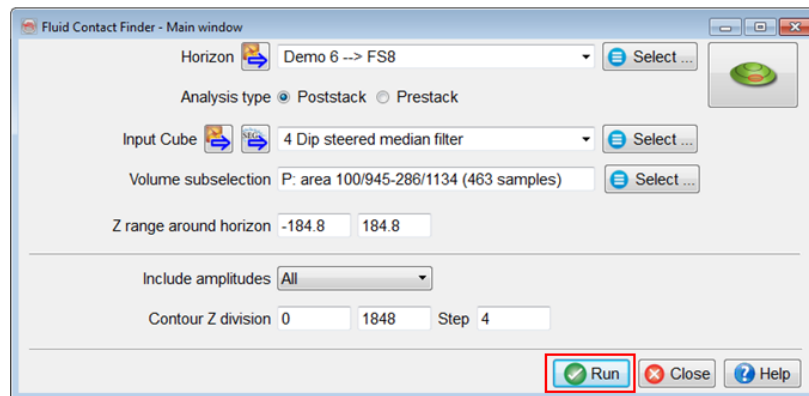

Display types available in FCF analysis window:

**Stack:** traces are stacked along depth/time contour bins and plotted as a 2D profile. The display can be flattened on a horizon. The stacked traces can be stored as a 3D volume if Flattened is checked.

**Single Z:** traces belonging to a single contour bin are displayed in a 2D viewer.

**Directional:** FCF-stacked amplitude at the horizon as a function of the distance to a selected position and the azimuth sector.

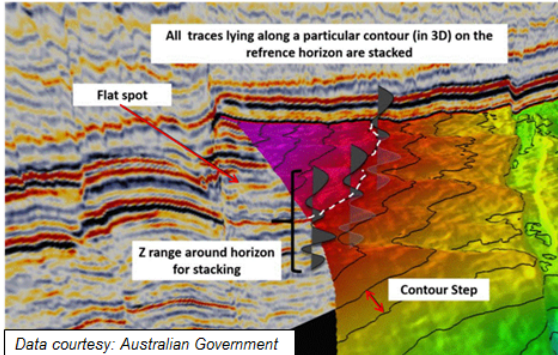
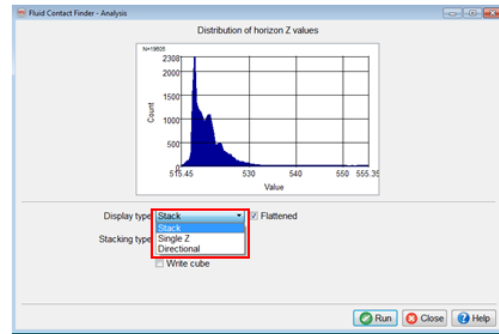

The image on the left (not from F3 Demo survey) illustrates the FCF stack concept.

**Workflow cont'd:**

19. **Choose** Display type as Stack, **uncheck** Flattened and **click** Run.

This window will remain open so that several FCF analyses can be run.

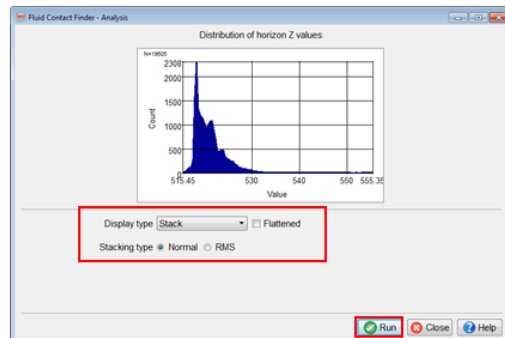

20. The FCF stack shows stacked traces along common contour bins of Demo 6 --> FS8 horizon. The possible fluid contact is highlighted: observe the drastic amplitude change at the flank of the structure.

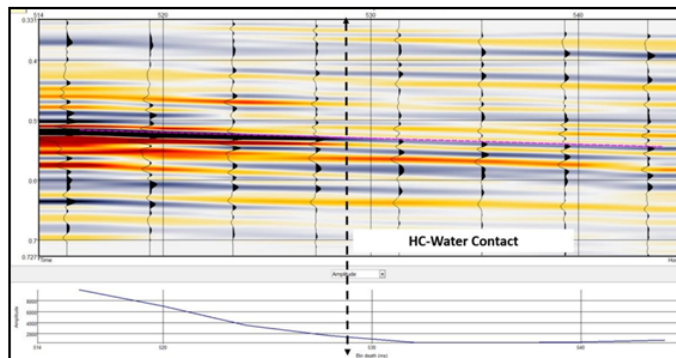

## 1.4.1a Well Tie

Required licenses: *OpendTect*.

### Exercise objective:

Tie a well to the seismic and extract a deterministic wavelet.

### Workflow:

1. **Right-click** on Well in the tree > Tie Well to Seismic...

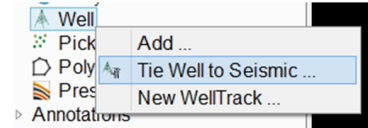

### Tip:

Well to seismic tie module can be also launched via:

- Analysis > Wells > Tie Well to Seismic...
- Right-click on a well name in the tree > Tie Well To Seismic...

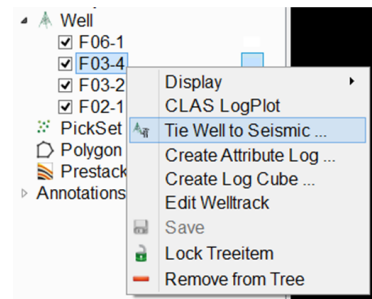
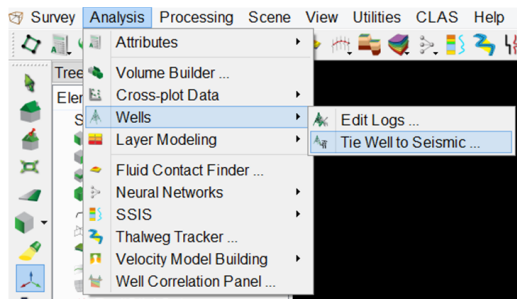

### Workflow cont'd:

2. In the Tie Well to Seismic window: **choose** F03-4 well, **check** the options to be as shown below and **click** Run.

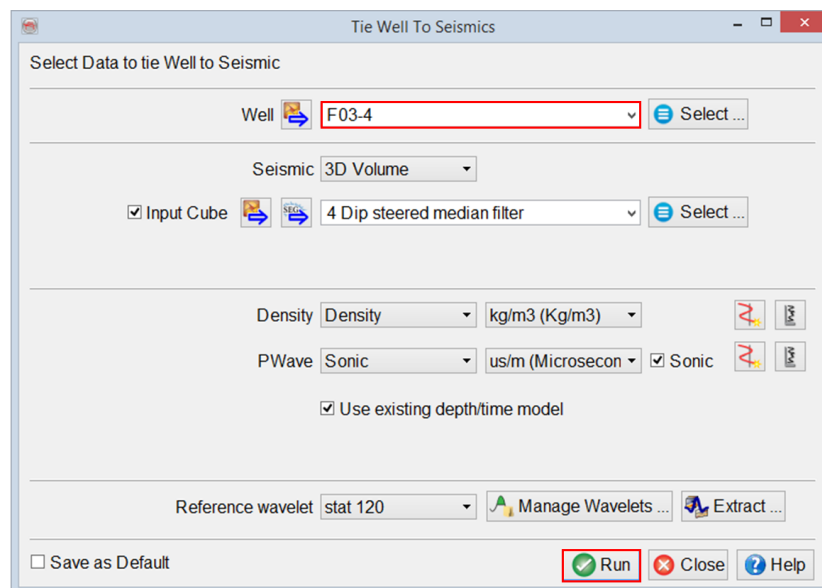

Workflow cont'd:

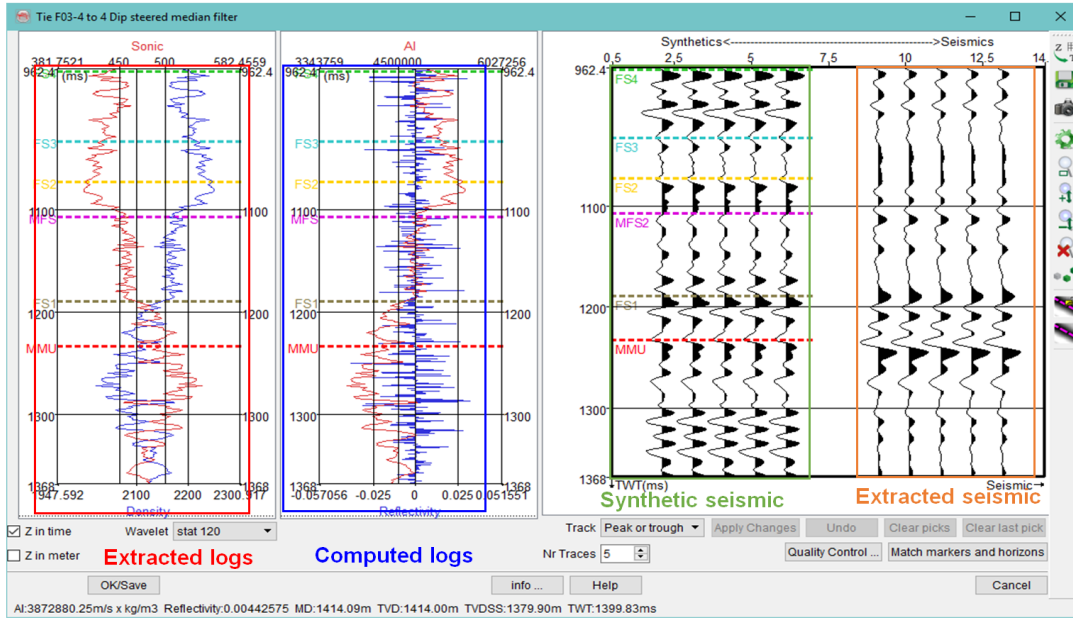

Markers are loaded by default.

Workflow cont'd:

3. Click on  icon to load already mapped horizons to be displayed on the extracted seismic traces: **Check** horizons from *Demo 1* to *Demo 7* and **click** OK.

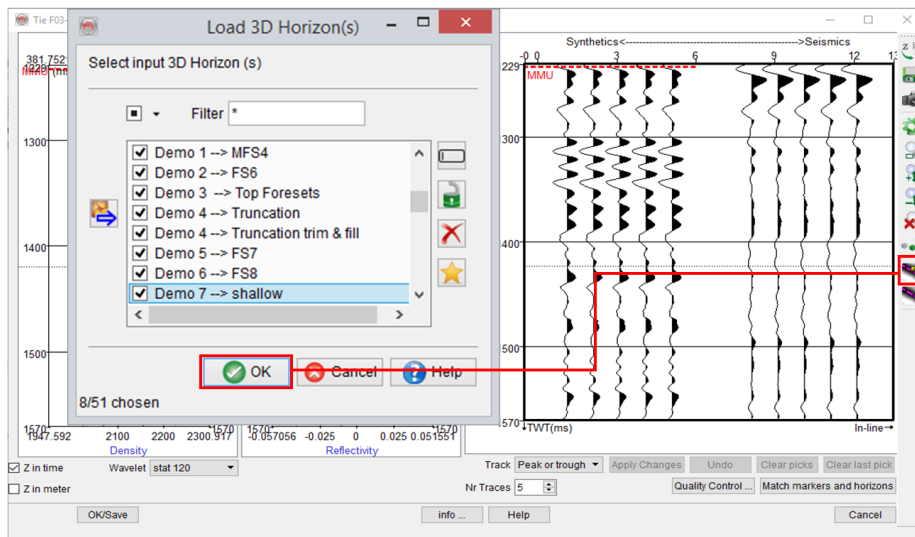

**Workflow cont'd:**

- Zoom in** using middle-mouse scroll button and **pan** by pressing middle-mouse button: **hold** and **drag** up/down until you have a display to pick matching events.

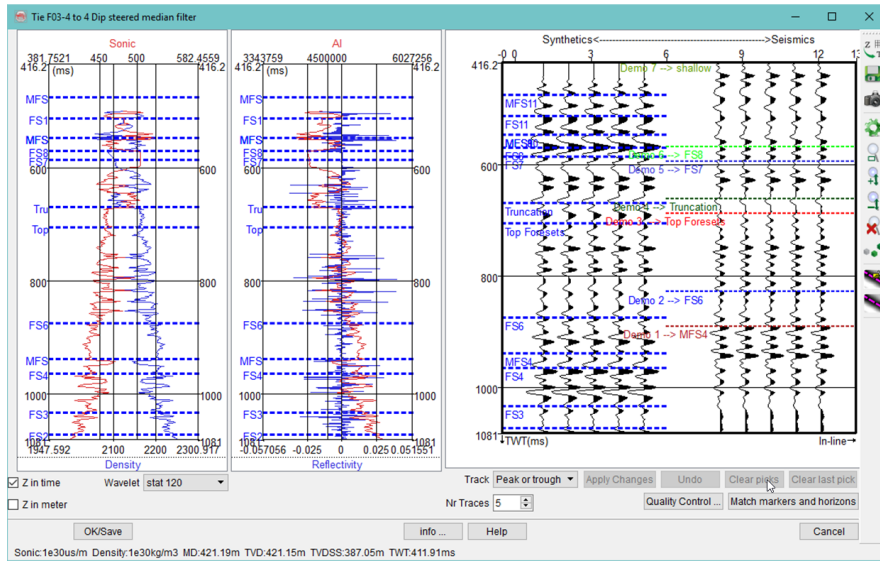

**Workflow cont'd:**

- Activate** pick mode with the icon
- Pick** matching events on the extracted seismic then synthetic traces (or synthetic then extracted seismic).
- Optionally, to **change** your picks: **click** Clear picks or Clear last pick if needed.

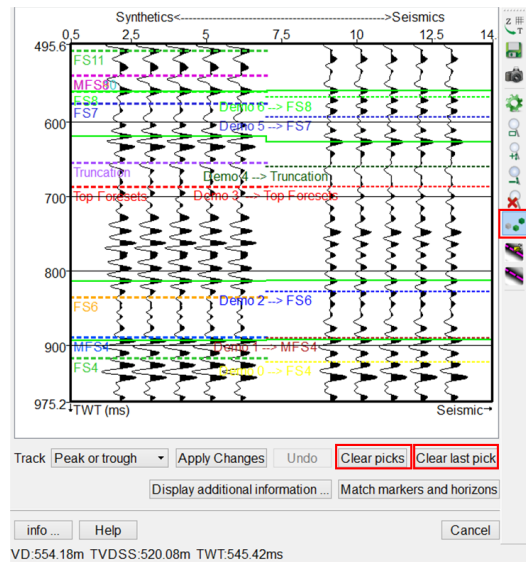

**Workflow cont'd:**

8. After picking the events, **click** Apply Changes to reflect the changes.
9. If not satisfied with the result, **click** Undo to revert the most recent step.

As only the previous step can be reverted using Undo button, it is recommended to save intermediate T/D (Time/Depth) curves by clicking on the  icon and exporting to a text file. Saved T/D curves can be (re-)imported at any time via the same window or via Well Manager.

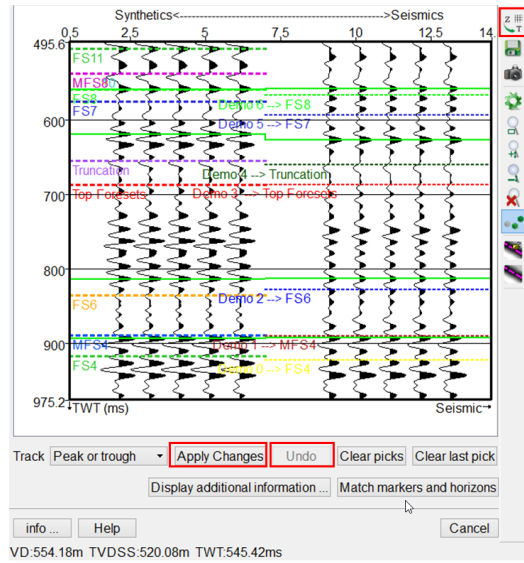

**Workflow cont'd:**

10. **Click** on Quality Control to check the Cross-Correlation Coefficient.

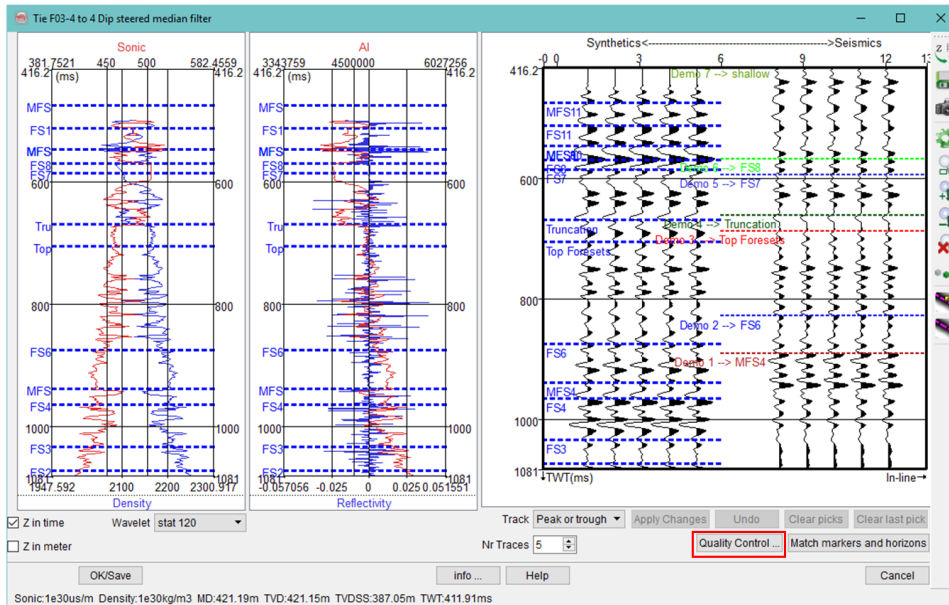

**Workflow cont'd:**

11. **Choose** Compute Data between Markers and **select** top and bottom markers, for example FS11 and FS3, to define a window of interest.

**Note** that Cross-Correlation Coefficient, the graph and the Estimated wavelet are immediately updated.

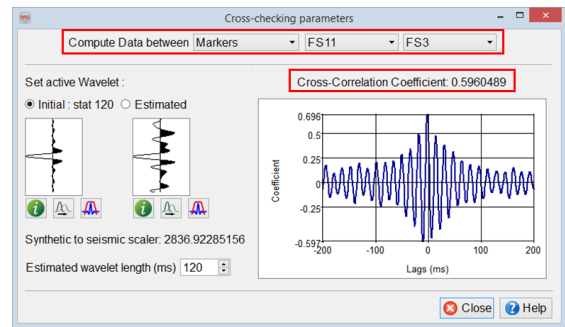

12. Optionally, **switch** to Estimated (deterministic) wavelet option: **see** that the synthetic traces change in the main Tie Well to Seismic window. The scaler applied to the seismic has also changed and should be close to 1.

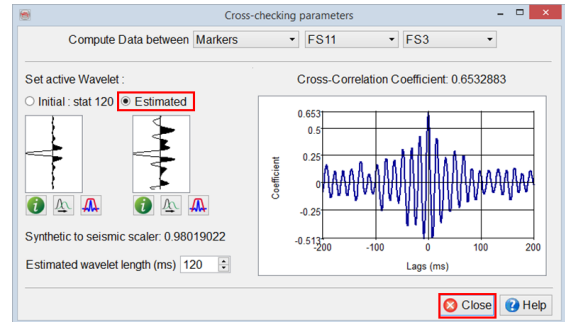

**Workflow cont'd:**

Click on  icon to save:

- Acoustic Impedance, Reflectivity and Synthetic as well logs or as seismic cubes.
- The initial (loaded) and/or estimated wavelet.

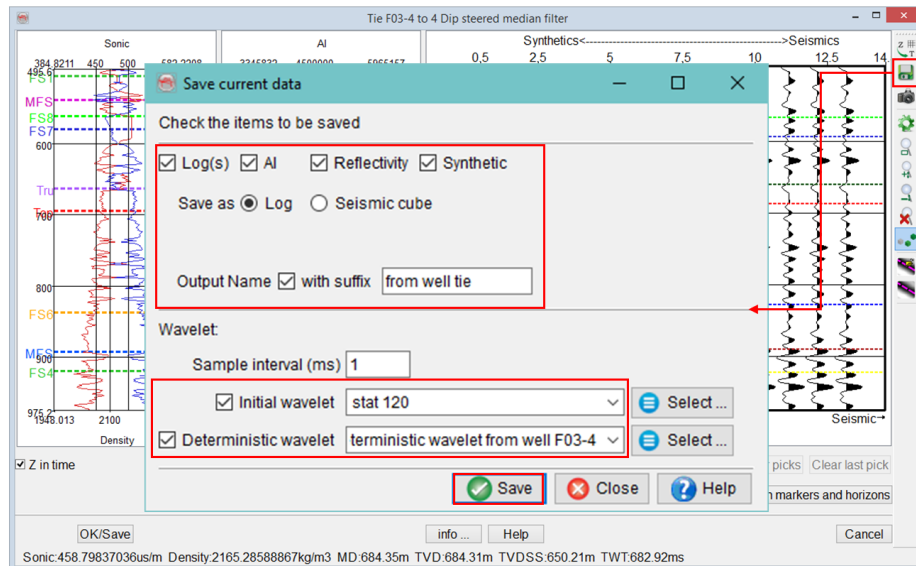

Workflow cont'd:

13. Click on OK/Save button to save the T/D curve as an active T/D model of the tied well.

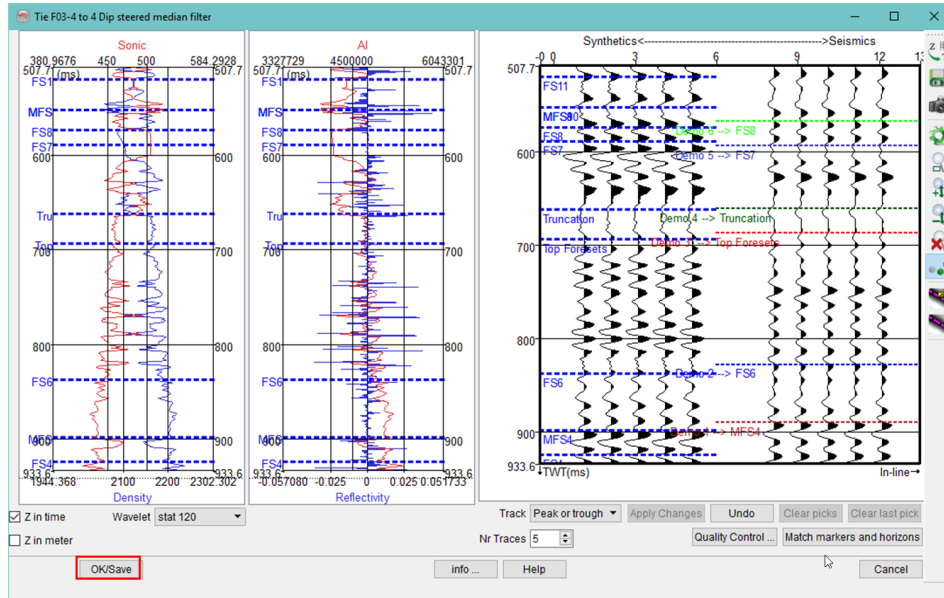



## 1.4.2a 3D Auto-track

Required licenses: OpendTect.

### Exercise objective:

Interpret a horizon using 3D auto tracking

### Workflow:

1. **Pre-load** 4 Dip steered median filter.
2. **Right-click** on Random Line > Add Default Data. The data displayed is 4 Dip steered median filter in the middle of the survey.
3. **Right-click** on 3D Horizon in the tree > New > Auto and Manual Tracking.
4. The Horizon Tracking Setup control center pops up (next slide).

### Survey > Pre-Load > Seismic...

For details on pre-loading see Exercise 1.3.1b.

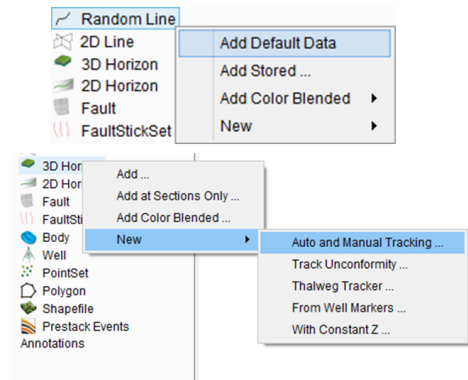

You can interpret on inlines, crosslines and random lines, in the 3D scene and 2D viewer.

### Workflow cont'd:

5. **Choose** the tracking mode: Section Auto-track (from seeds) and **Select** Seed Trace as tracking method.

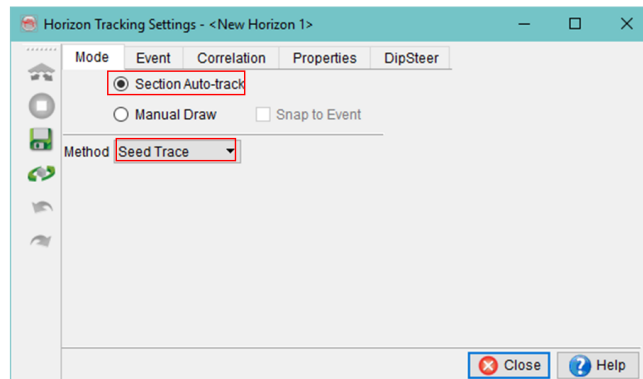

### Method:

- Seed trace: compares amplitudes against the seed reference (recommended for most horizons)
- Adjacent parent: compares amplitudes against the last tracked position (increased risk of loop-skips; recommended for easy horizons).

**Workflow cont'd:**

6. **Click** on the Event tab.
7. **Select** event type Peak and leave the search window as default for now.

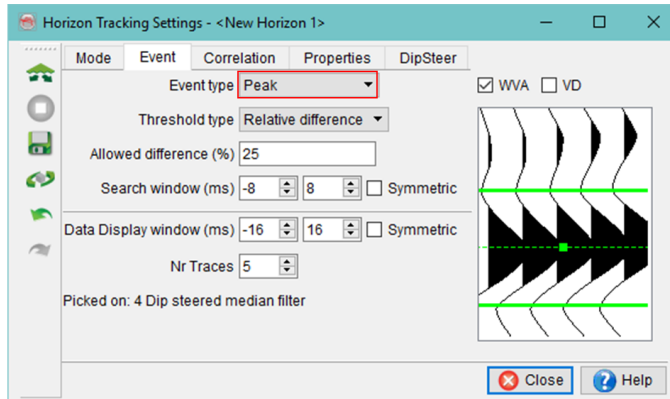

*Display after picking a seed*

- Use the green lines in the waveform display to change the search window
- It is possible to change the event type during the interpretation

**Workflow cont'd:**

8. **Click** on the Correlation tab.
9. **Set** the use Correlation toggle to Yes.
10. **Set** the Correlation threshold to 60%.

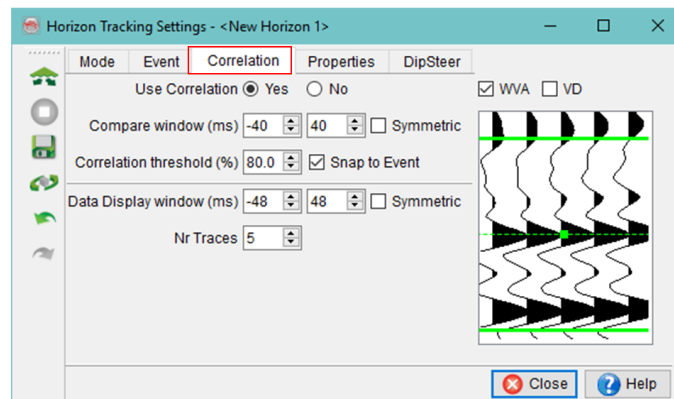

Tracking with correlation is more accurate, but it takes more time to compute.

**Workflow cont'd:**

11. **Set** the selection of Steering to No.

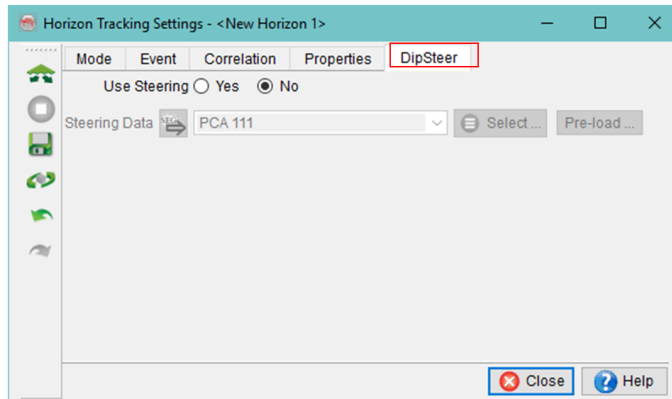

This option is only available if you have a dip-steering license. It ensures that the correlation window follows the seismic reflectors by steering the window along the pre-calculated dip. This option lowers the risk of loop-skips, especially in areas with steep dips.

**Workflow cont'd:**

12. Optionally **edit** the display properties.

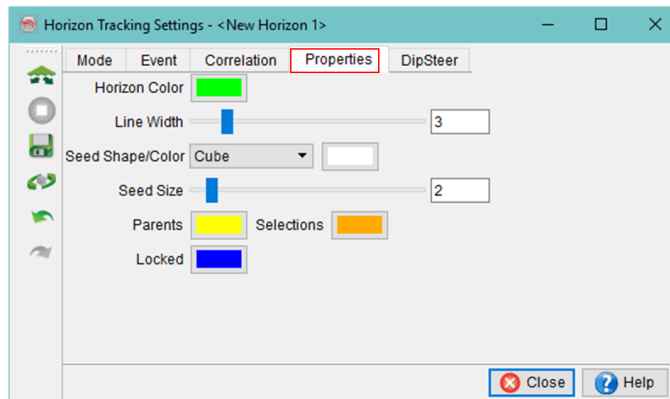

We recommend the Horizon Tracking setup window to stay open during the entire interpretation session. Parameters can thus be adjust at all times. To re-open the window, use the ✂ icon in the toolbar in the lower section of OpendTect main window.

**Workflow cont'd:**

13. **Pick** a seed on a Max event (as selected earlier) on the displayed random line.
14. **Click** on the  Auto-Track icon in the Horizon Tracking Setup window.

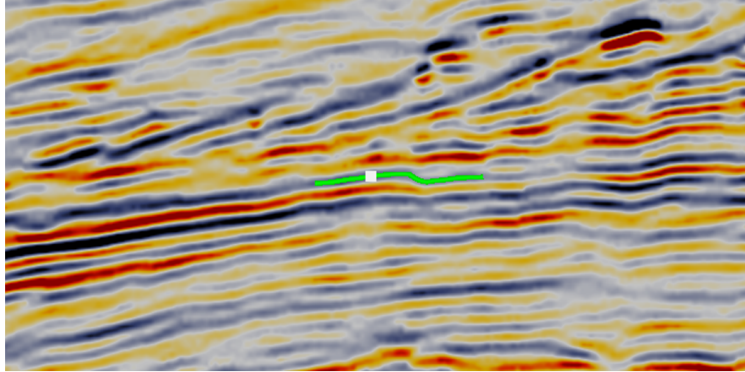

In horizon picking mode, the cursor is a cross. You need to have the horizon active in order to interpret. You can make it active by clicking on it in the 3D scene or on its name in the tree.

**Workflow cont'd:**

15. **QC** the auto-tracked horizon patch:
  - a. **Select** the new horizon in the tree.
  - b. **Set** the display of the horizon to "sections only": **press** the shortcut v/V key.
  - c. **Move** the random line through the patch: **click** and **drag** the line.
16. If the horizon patch looks OK but is rather small: **change** the amplitude correlation parameters and redo.  
In this case, **change** the correlate window to [-20, 20] ms.
17. **Click** on the Retrack-All icon  in the Horizon Tracking Setup window.

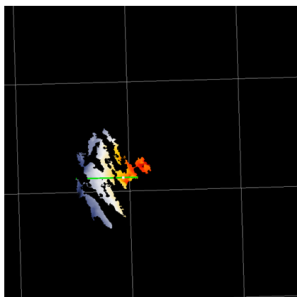

Correlation window [-40;40]ms

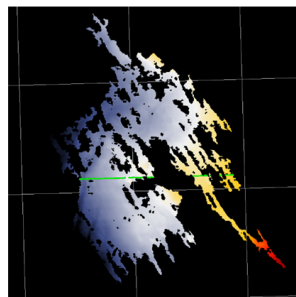

Correlation window [-20;20]ms

**Workflow cont'd:**

18. When satisfied with a patch, **right-click** on it > Tracking > Lock, so that it can no longer be changed. Alternatively, **Ctrl + right-click** on it > Lock.

19. To continue, **pick** another seed in an empty area and repeat the exercise.

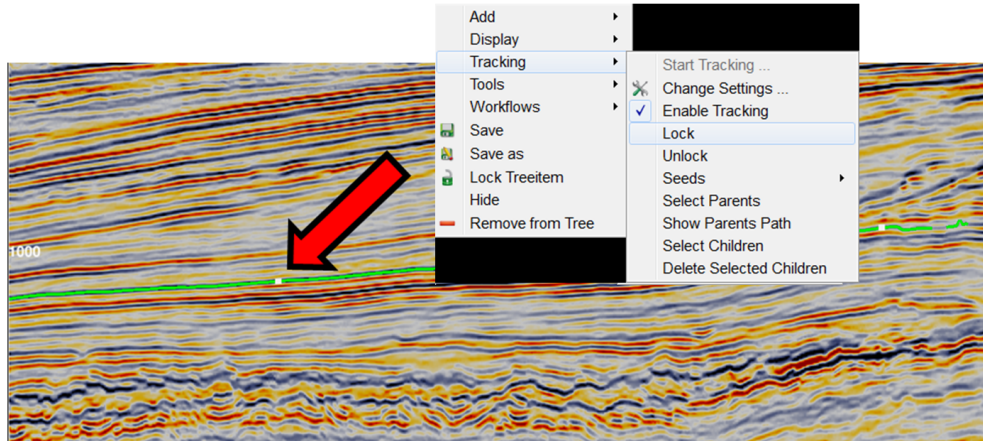

**Workflow cont'd:**

20. **Click** on the auto-track icon  to track more from the new seed (previously auto-tracked horizon patch remains untouched).

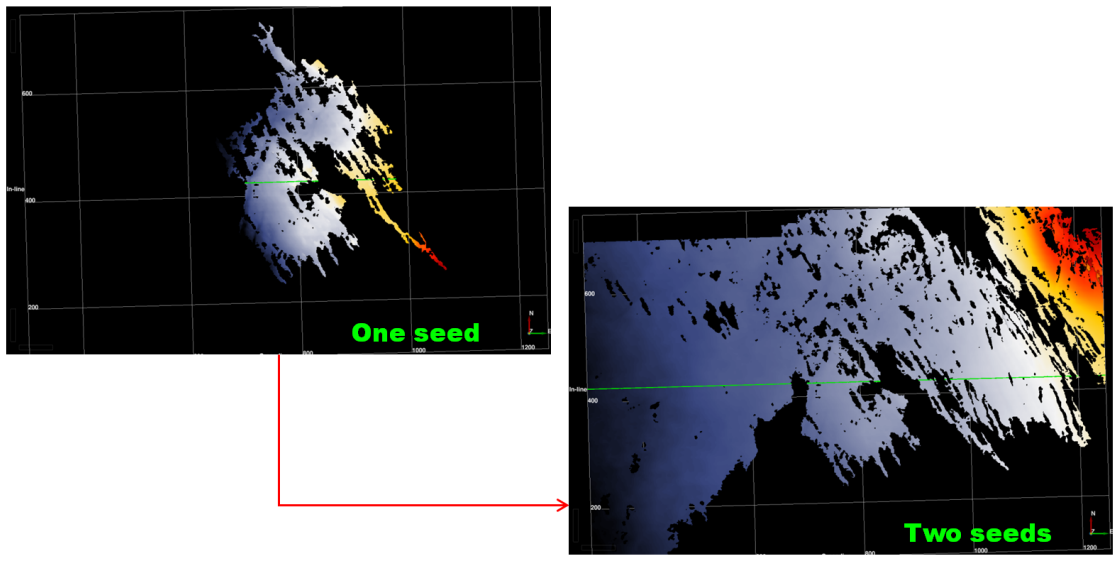





### Workflow cont'd:

21. **Repeat** this workflow (add seeds, auto-track, QC, lock) until you have filled the entire area with horizon patches of good confidence.
22. Now **lower** the constraints in the amplitude and correlation tabs.
23. **Repeat** steps 21 and 22 until the tracker cannot fill in holes any further without making mistakes.

### What to do when something went wrong?

There are three ways to change the results:

- Use Undo  and Redo  icons, or CTRL-Z / CTRL-Y shortcuts.
- Select the area to remove with the selection  icon and press the  delete icon.
- Use the tracking history to remove all positions (children) following the last good position (parent). How to do this is explained next.

### Workflow cont'd:

How to see the tracking history

24. **Right-click** in the 3D scene on a bad position on the auto-tracked horizon and **Go** to Tracking > Show Parents Path.
25. Alternatively, **ctrl + right-click** on the bad position on the auto-tracked horizon and **select** Show Parents Path.

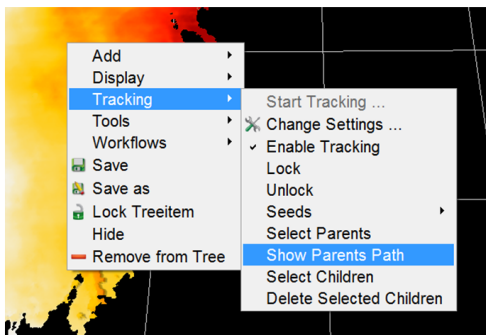

OR

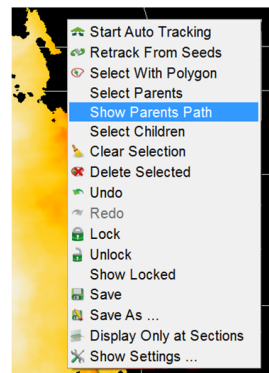

**Ctrl + right-click** pops up the dedicated menu containing all the tools required for 3D horizon tracking. This menu minimizes the need to use the horizon tracking set-up window, e.g. for auto-tracking or re-tracking from seeds.

**Workflow cont'd:**

26. The nodes of the random line that appears in the 3D scene shows the tracking path to the selected position (Parents Path).

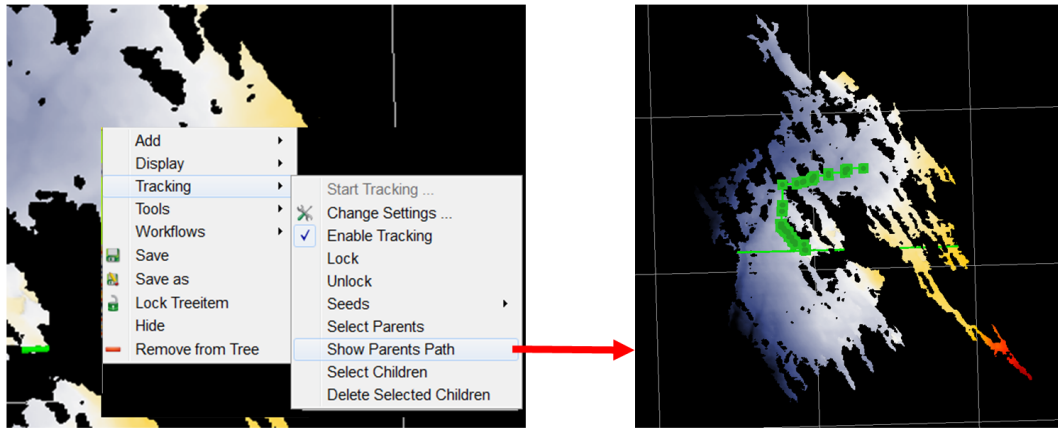

Each node (in Green) of the random line, corresponds to a parent seed.

Each parent path is added in the tree under the Random line item and can be saved.

**Workflow cont'd:**

27. Additionally, the Parents Path random line is automatically displayed in a 2D viewer.

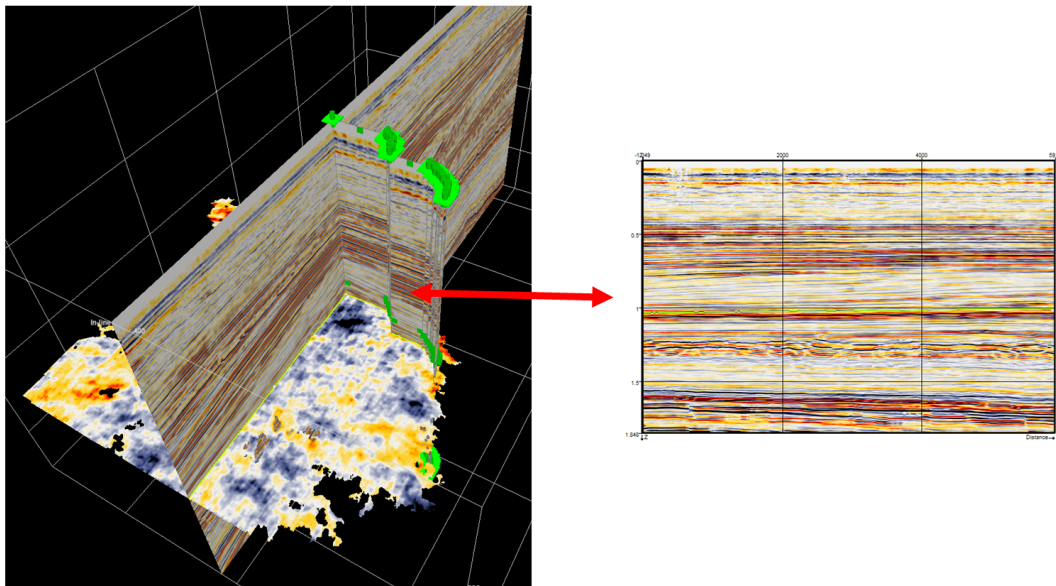

**Workflow cont'd:**

28. **Locate** the parent position where the interpretation went off-track: **Ctrl + right-click** on this position on the horizon patch (or in the 2D viewer) and **select** Select Children.
29. The samples tracked from this bad parent position are highlighted in the scene. Either, **right-click** on them > Tracking > Delete Selected Children or **Ctrl + right-click** on them > Delete Selected.

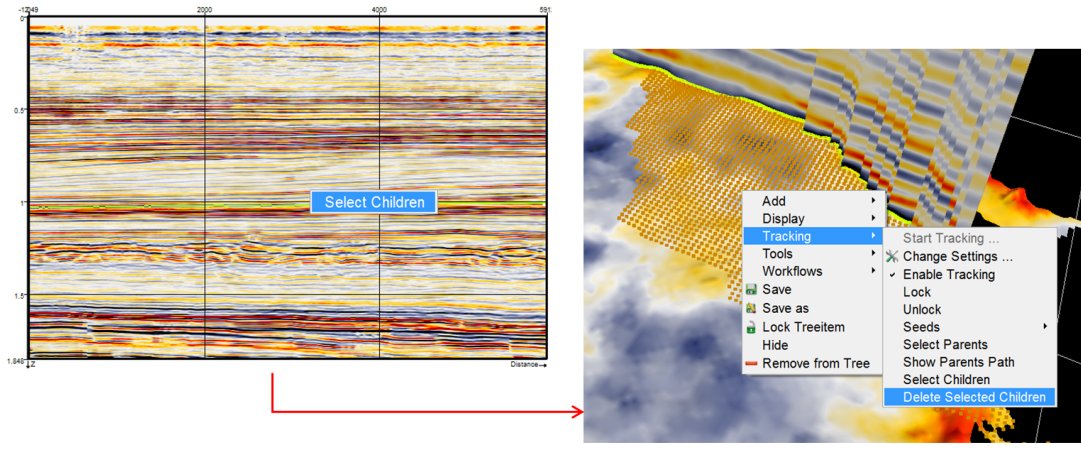

**Workflow for “fast” auto-tracking using “Adjacent Parent” tracking method**

1. **Select** Adjacent Parent method in the Mode tab.
2. **Go** to the Event tab and **Select** Relative difference as Threshold type.
3. **Define** the allowed differences by clicking on Steps ...

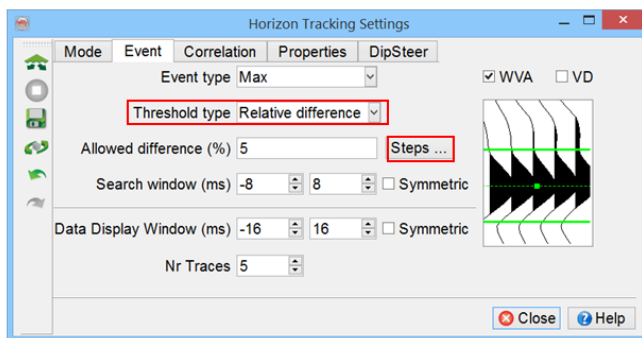
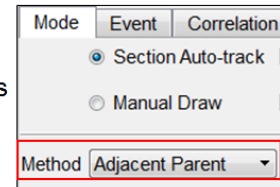

Patches tracked with the Adjacent Parent method tend to be much larger than with the Seed Trace method, especially if you use multiple steps (next slide)



---

**Workflow cont'd:**

4. **Specify** the allowed differences (in %) as shown on the picture. In this example any sample of the horizon is tracked in at-most 5 steps.

In the first step only 1% difference between neighbors is allowed. If the program is able to find a new sample in the neighborhood with less than 1% amplitude difference, that sample is included in the horizon and tracking moves on. Otherwise, the amplitude difference criteria of next steps are utilized. Be aware that loosening the constraints too much may result in loop-skips.

Event type Peak  
Threshold type Relative difference  
Allowed difference (%) 1, 2, 5, 10, 20  
Search window (ms) -20 20  Symmetric

Adjust the amplitude and correlation parameters in case the tracker stops tracking too soon.

5. **Follow** steps 8-29 of the previous workflow based on the Seed Trace method.

## 1.4.2b Tracking In 2D Viewer

### Exercise objective:

Interpret a 2D horizon using a 2D viewer

### Workflow:

1. **Add** a 2D line to the 3D scene: **right-click** on 2D line and **go** Add.
2. **Select** the Well correlation - Line and **change** the action to Load default data.
3. Once the 2D line is loaded, **right-click** on the attribute name (i.e. *Seis*) in the tree and **go** Display > 2D viewer.

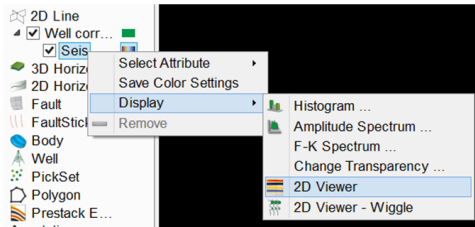
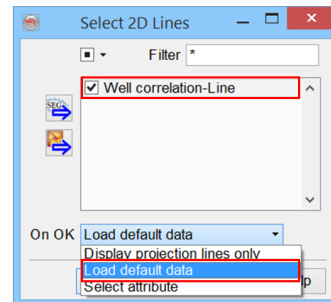
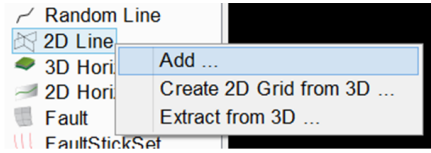

In a 2D viewer, you can interpret 2D and 3D seismic.

### Workflow cont'd:

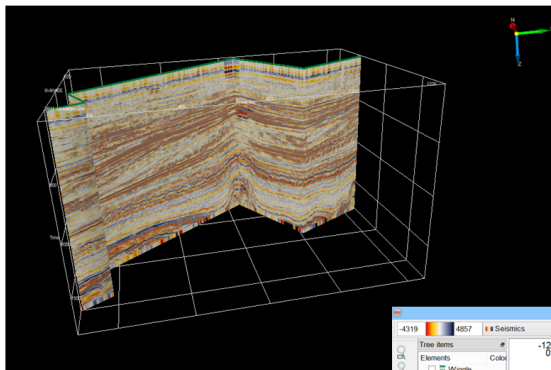

3D scene

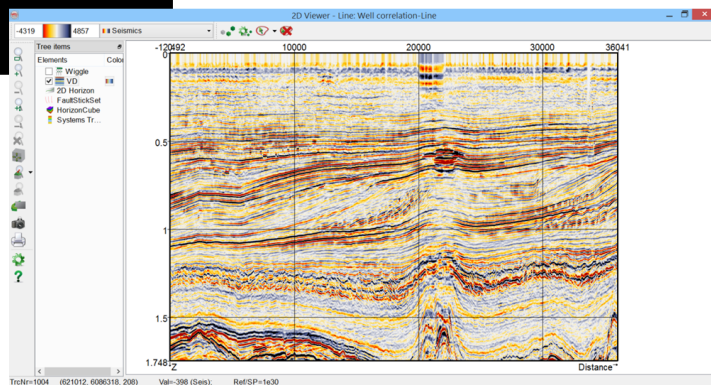

2D viewer

**Workflow cont'd:**

- In the 2D viewer, **right-click** on 2D horizon and **select** Track new.
- In the Horizon tracking settings, **leave** the parameters as default.
- Optionally, **close** the Horizon tracking setting window

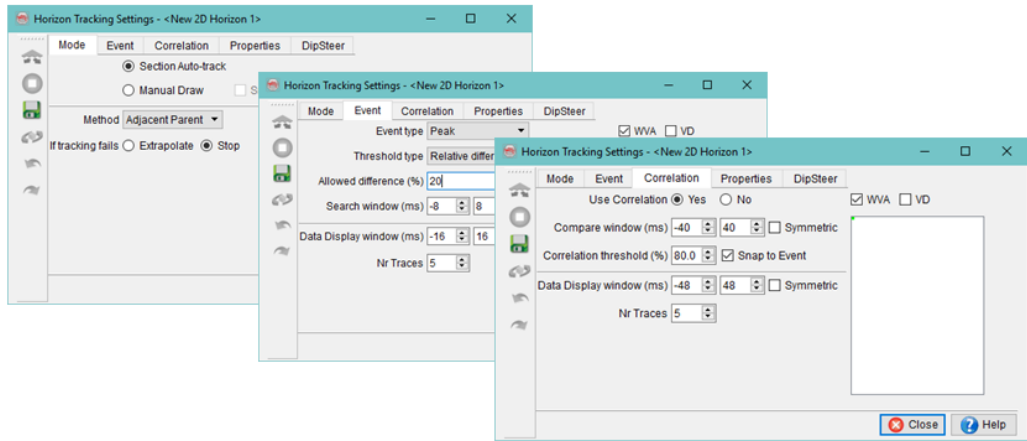
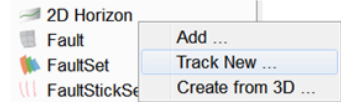

**Workflow cont'd:**

- Pick** a seed on a Max event (as selected earlier) on the line.
- Interpret** the full line.

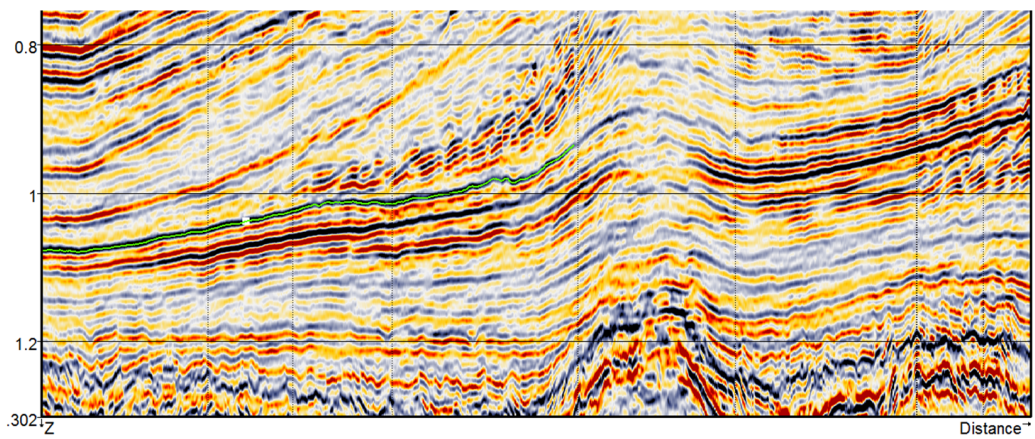

**Workflow cont'd:**

8. In some areas the horizon does not propagate well and you may want to switch to the manual drawing mode.

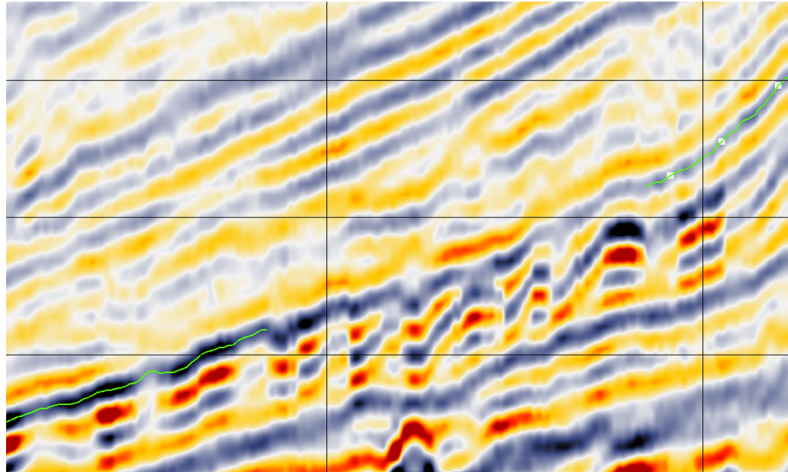

**Workflow cont'd:**

9. **Re-open** the horizon tracking settings: **right-click** on the <New 2D Horizon> and Tracking > Change Settings.
10. **Change** the tracking mode to Manual Draw and **select** the Snap to event option. The event type is defined as previously.

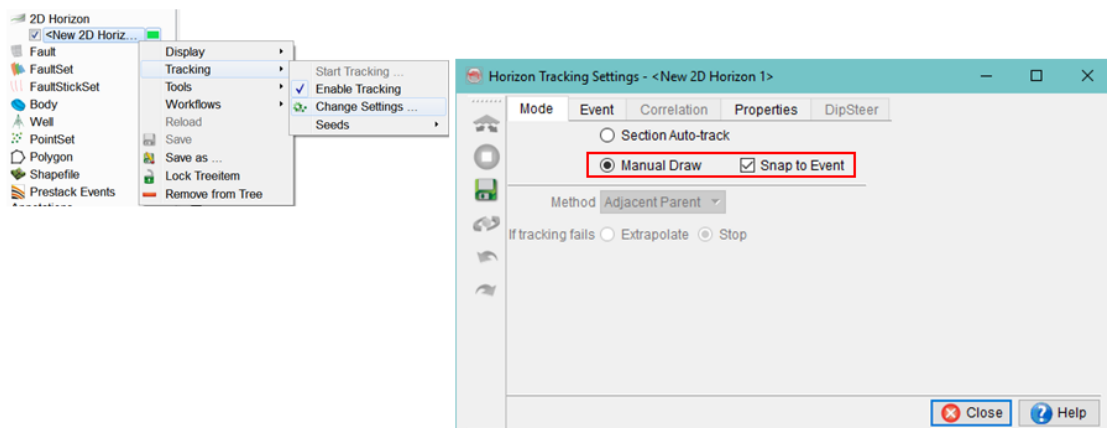

Workflow cont'd:

11. **Draw** the line where you want to interpret.

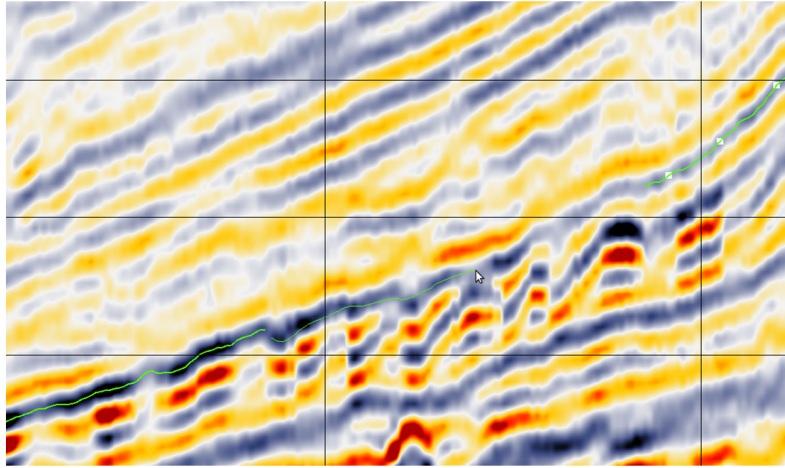

Workflow cont'd:

12. Once you are done, **release** the left-click button from your mouse: the line will be automatically converted into the horizon and snapped to the Max event.

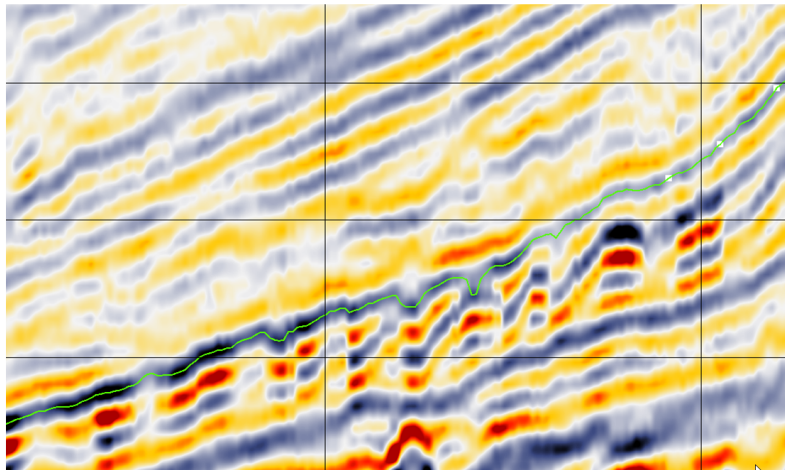

**Workflow cont'd:**

13. When satisfied of the interpretation, **save** the 2D horizon: **right-click** on the *<New 2D Horizon>* in the 2D viewer tree and **select** Save as (at this point Save and Save as are equivalent) and **specify** an output name.
14. **Close** the 2D viewer.  
The 2D line and the newly interpreted 2D horizon are displayed in the 3D scene.

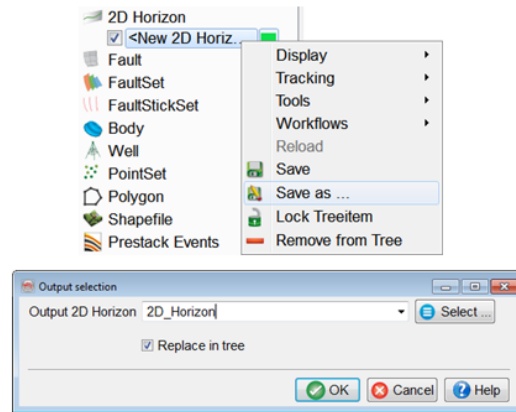

*Note: A 3D horizon as well as Fault stick sets can also be interpreted in the 2D viewer.*

**Workflow cont'd:**

**3D horizon interpretation using a 2D viewer**

1. The horizon type you are interpreting is 3D horizon.
2. The tracking modes are similar but on the contrary to the 2D tracking, the auto-tracking option is ON while tracking a 3D horizon in a 2D viewer.
3. For auto-tracking the horizon, recommendation is to use the Seed trace method in combination with the section auto-track option (see previous exercise 1.4.2a for more details).
4. In the 2D viewer, while tracking a 3D horizon, you can switch inline/crossline by either typing the line number or using the arrows and the step to interpret a grid like you would do in the 3D scene.

## 1.4.3a Fault Planes

Required licenses: *OpenTect*.

**Exercise objective:**  
Pick a major fault plane.

**Workflow:**



- Right-click** on In-line in the tree > Add Default Data; 4 Dip steered median filter.
- Change** In-line position and step: **enter** manually 250 and 10 in the In-line and Step fields, respectively, of the navigation toolbar.
- Click** on  to have an In-line view.

In-line 250: 4 Dip steered median filter.

**Workflow cont'd:**

- Right-click** on Fault in the tree > New.
- Right-click** on the newly added Fault > Save as...
- Enter** an Output Fault name and **click** OK.
- Right-click** on the saved Fault name > Display > **toggle on** Only at Sections.

### Workflow cont'd:

- Pick** the fault on the first In-line: either **Left-click + drag** or **Left-click** to pick and **double-click** to end a stick.
- Edit** as needed: **Left-click + drag** seeds, **Ctrl + Left-click** to remove seeds,  or **Ctrl + Z** to undo the last action,  or **Ctrl + Y** to redo.

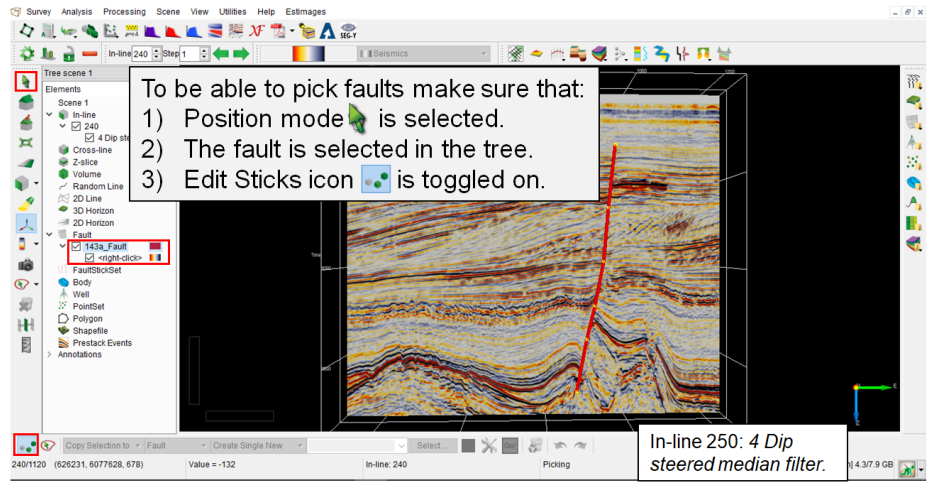

### Workflow cont'd:

- Move** the In-line to a new location (for example 240): **Click** on  in the navigation toolbar or use short keys (Z and X by default) to move the In-line backward and forward.
- Repeat** steps 8, 9 and 10 for every 10<sup>th</sup> inline in the range 100-250.

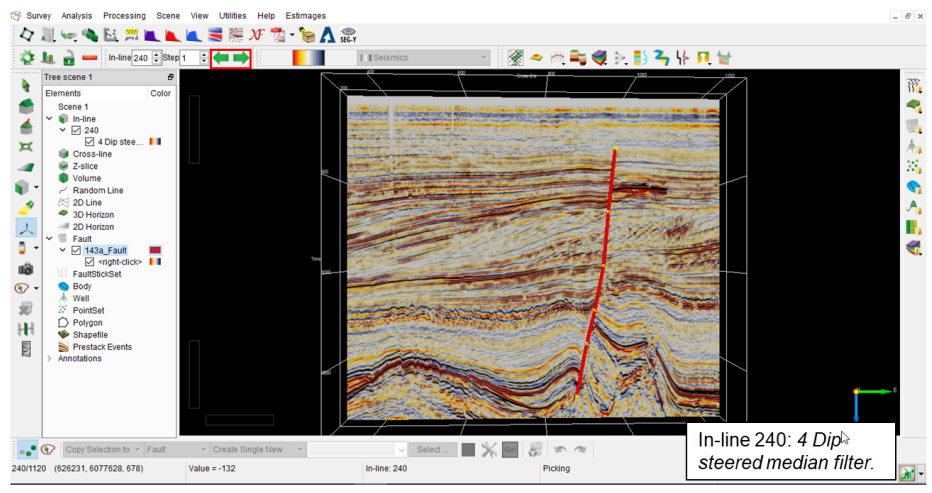



**Workflow cont'd:**

12. **Right-click** on the fault name in the tree > Display > **toggle off** Only at Sections, to see the fault plane in 3D. (Shortcut key: v)

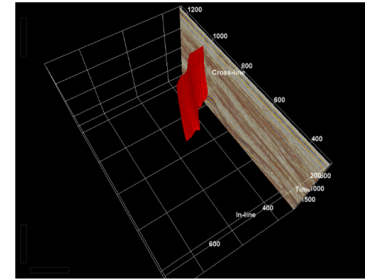
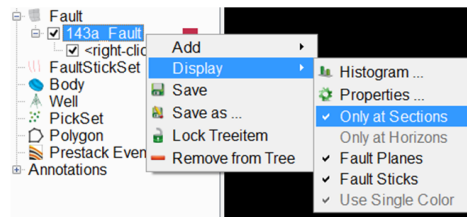

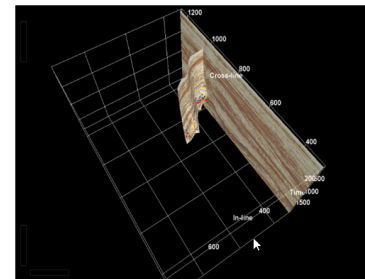
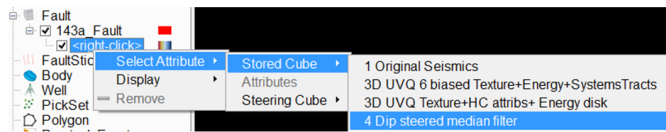

13. Optionally **display** the seismic data along the fault. **Right-click** > Select Attribute > Stored Cubes > 4 Dip steered median filter.

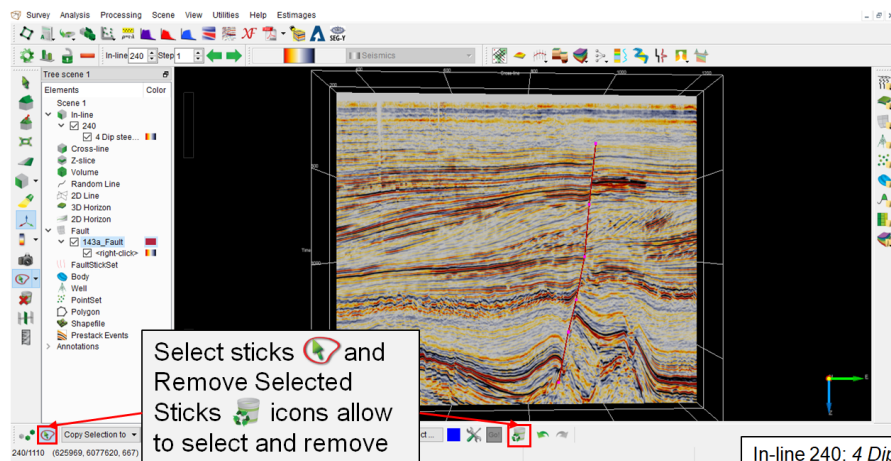
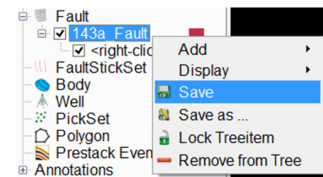

**Workflow cont'd:**

14. Don't forget to **Save** your work regularly.
15. To delete sticks from a fault plane, **use** Select and Remove icons as shown below.



Select sticks  and Remove Selected Sticks  icons allow to select and remove fault sticks.

In-line 240: 4 Dip steered median filter.

## 1.4.3b Fault Sticks

Required licenses: *OpendTect*.

### Exercise objective:

Pick a set of fault sticks and group these into fault planes.

### Workflow:

1. **Right-click** on In-line in the tree > Add Default Data; 4 Dip steered median filter.
2. **Drag** inline position to 110 in the Position mode .
3. **Click** on  to have an inline view.
4. **Reduce** the displayed area to the faulted part as shown in the picture: **Left-click + drag** the green square in the upper right corner.

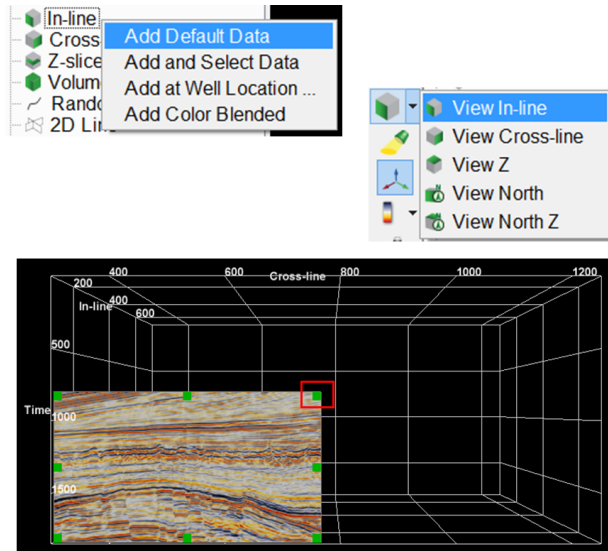

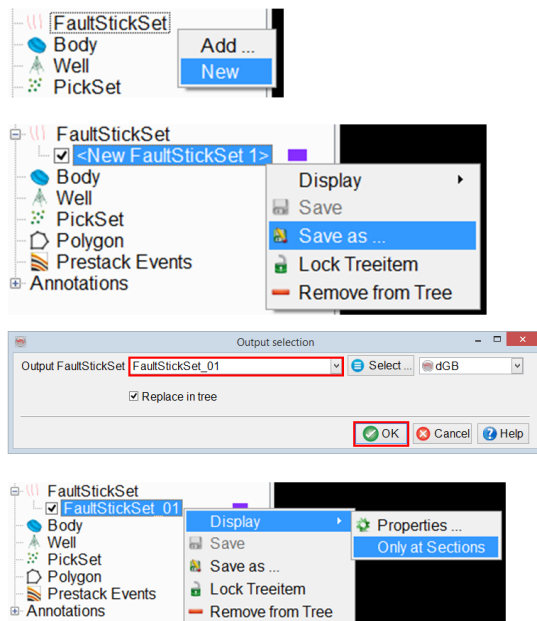

### Workflow cont'd:

5. **Right-click** on FaultStickSet in the tree and **select** New.
6. **Right-click** on the newly added FaultStickSet > Save as...
7. **Enter** an Output Fault Stick Set name and **click** OK.
8. **Right-click** on the saved FaultStickSet name > Display > Only at Sections.



**Workflow cont'd:**

9. **Pick** the first fault stick: either **Left-click + drag** or **Left-click** to pick and **double-click** to end a stick.
10. **Edit** as needed: **Left-click + drag** seeds, **Ctrl + Left-click** to remove seeds,  or **Ctrl + Z** to undo the last action,  or **Ctrl + Y** to redo.

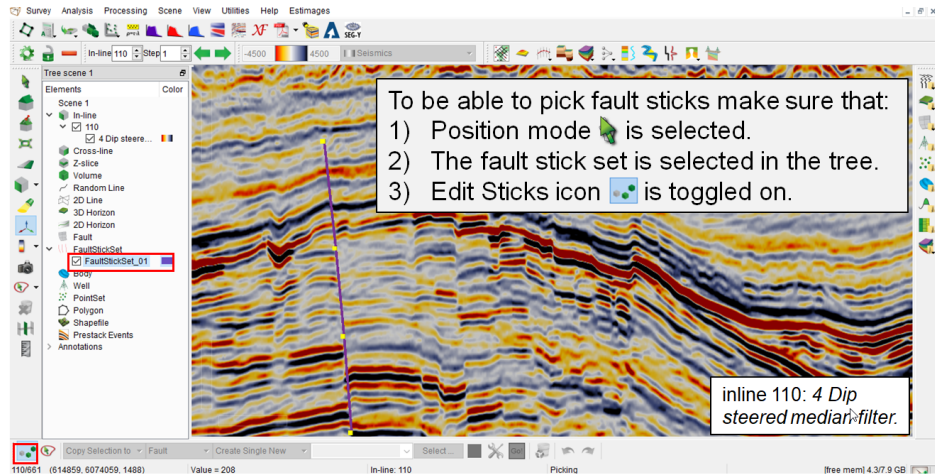

**Workflow cont'd:**

11. **Save** your work regularly.
12. **Interpret** several fault sticks on inline 110.

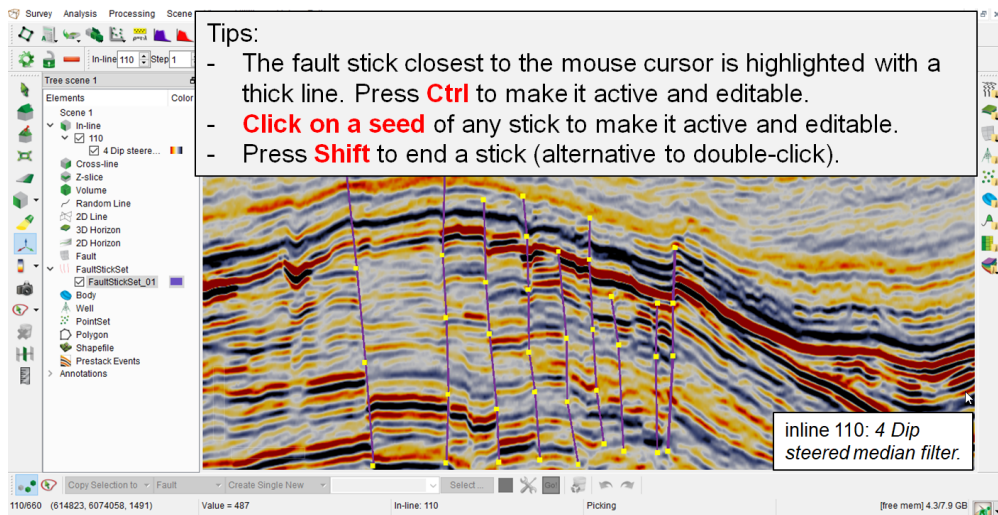
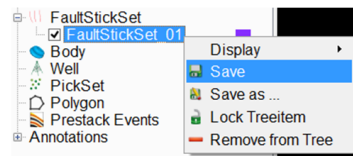

**Workflow cont'd:**

13. **Move** to inline 120: **Click** on  in the navigation toolbar or use short keys (Z and X by default) to move the inline backward and forward. **Continue** the interpretation for several inlines, e.g. with a step of 10.

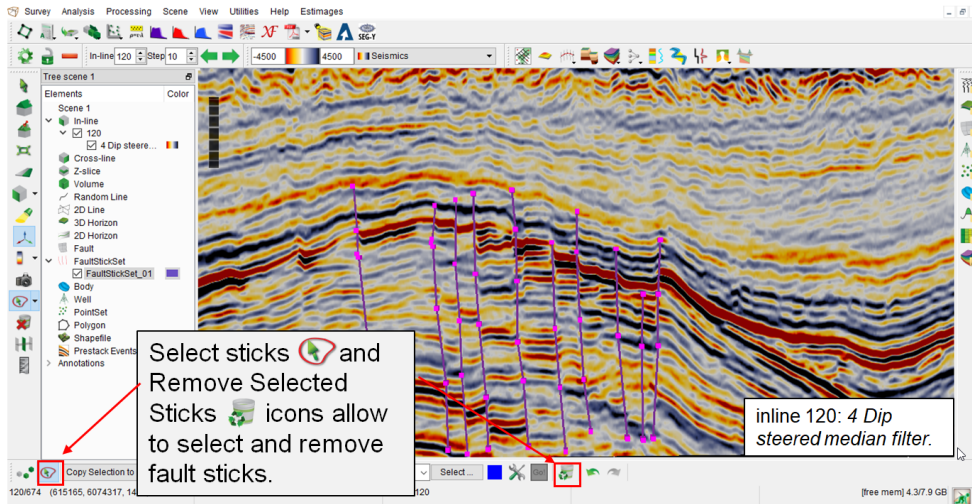

**Workflow cont'd:**

14. **Add** an empty Z-slice\* to the scene and **Drag** it to 1500 ms. **Click** on  to have a North oriented top view and resize with the green anchors to cover more or less the area you interpreted.

We have finished picking sticks. In the next phase sticks will be grouped into planes. To facilitate this process we will display a fault discontinuity attribute on a time-slice through the sticks.

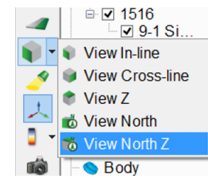
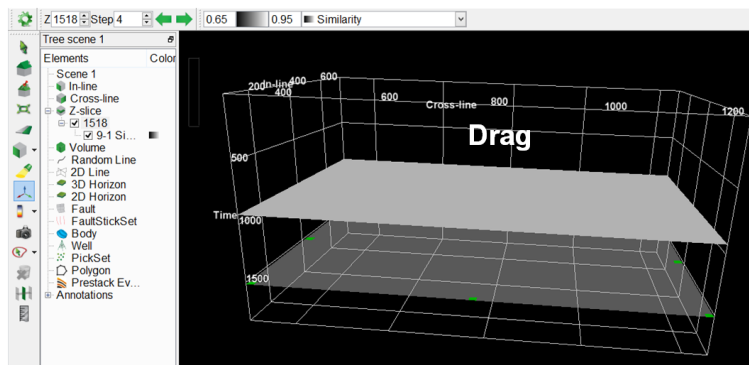

\*Positioning an empty slice is faster than positioning a slice with data. With pre-loaded data the speed difference is negligible.

**Workflow cont'd:**

15. **Add** 9-1 Similarity on FEF seismic from Stored attribute list.

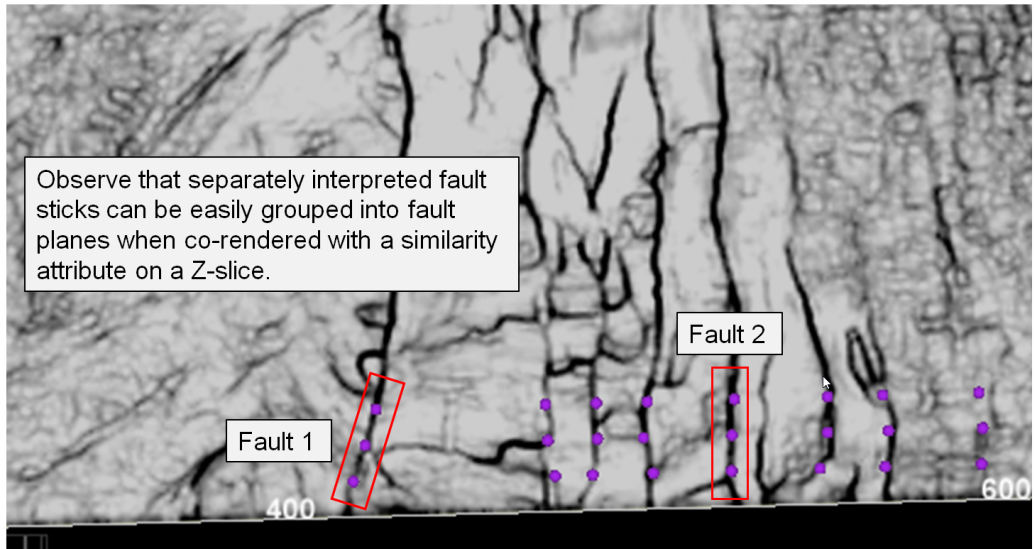

**Workflow cont'd:**

16. **Select** sticks located along the same lineament by clicking on  icon and:

- **Ctrl + Left-click** to select/de-select sticks one by one;
- **Left-click + drag** to select/de-select a group of sticks;
- **Ctrl + Left-click + drag** around several groups of sticks for multi-group selection.

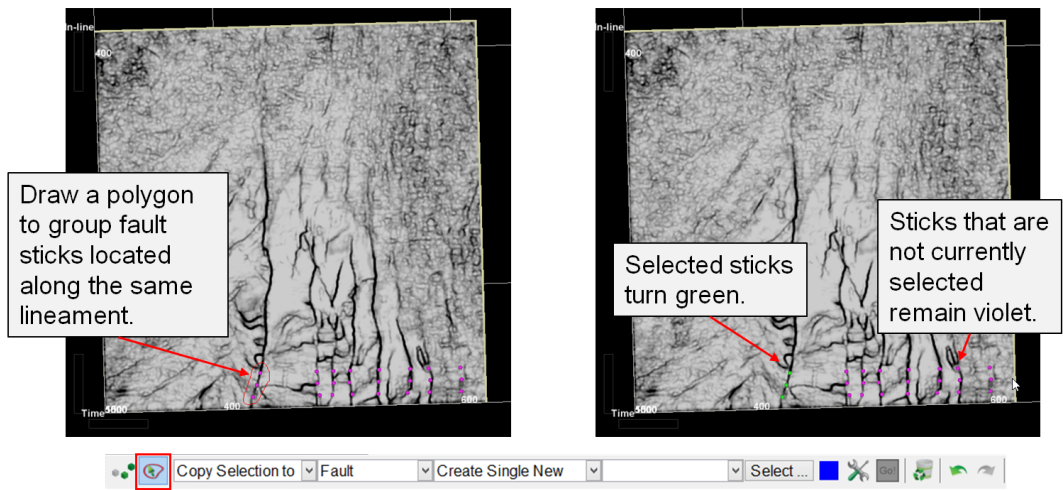

**Workflow cont'd:**

17. **Choose** Copy Selection to > Fault > Create Single New and type in a new name in the toolbar. Optionally choose a fault color. Then **click** .



18. **Repeat** previous two steps to create more fault planes.

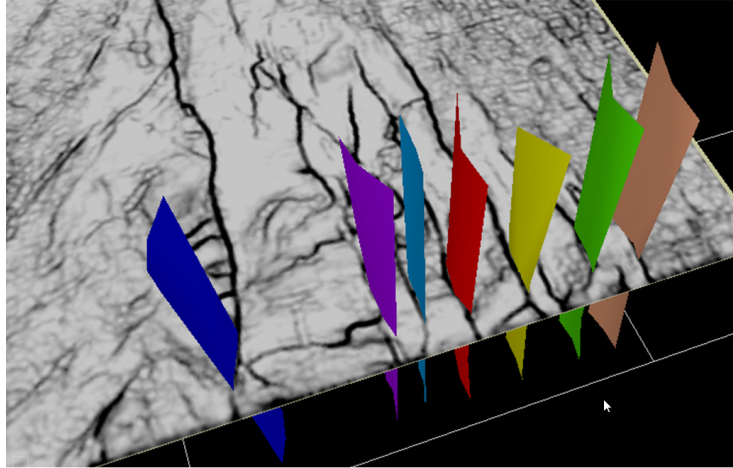

## 2.1.4a Thalweg Tracker

Required licenses: OpendTect Pro.

### Exercise objective:

Track a channel (and its associated margins) using the Thalweg tracker.

### Workflow:

1. **Add** an inline with default data in the scene.
2. **Launch** the Thalweg tracker from the Analysis menu (Analysis > Thalweg tracker) or **click** on  icon.
3. The default data volume for this survey will appear automatically in the Input Cube field.

The Thalweg tracker is not a conventional tracker: it is using a weighted voxel approach to track seismic facies. Hence it is not limited to map channels.

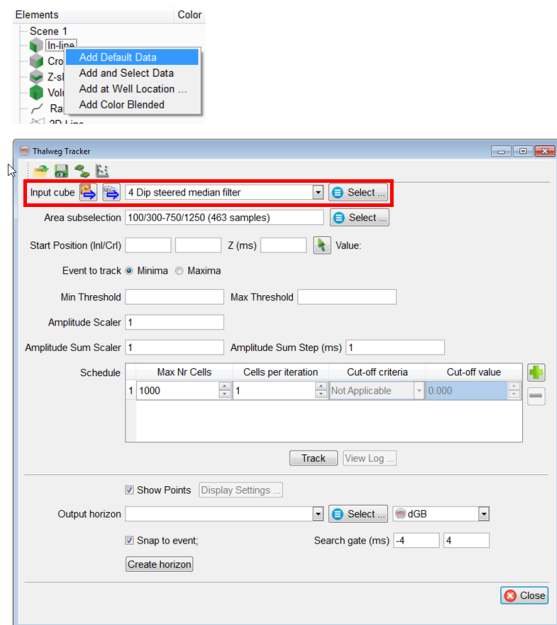

### Workflow cont'd:

4. **Move** the inline to 365: **click** on the inline 425 and **type in** 365 in the Slice Position toolbar, or **use** the basemap and **drag** the inline to the wanted position.
5. **Pick** an event: **press**  icon and **pick** a seed at crossline 647 at 1024ms.

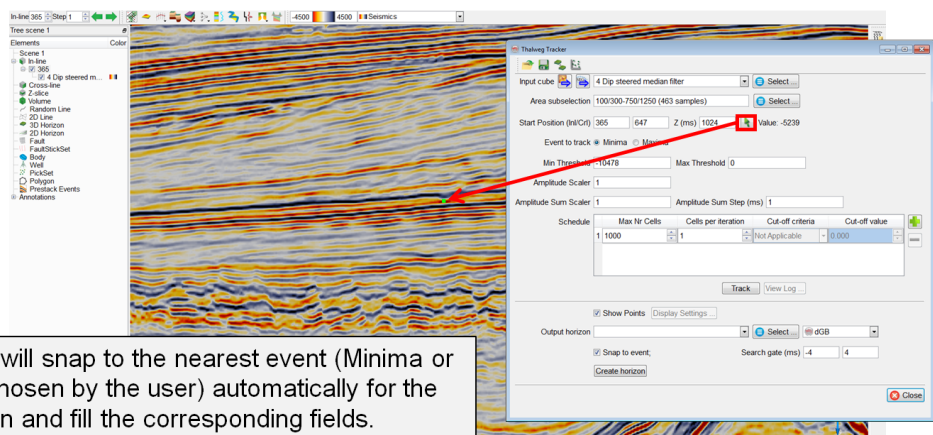
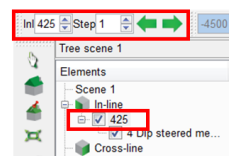

The software will snap to the nearest event (Minima or Maxima, as chosen by the user) automatically for the picked position and fill the corresponding fields.

**Workflow cont'd:**

6. **Keep** default values for Amplitude Scaler, Amplitude Sum Scaler and Amplitude Sum Step (ms).
7. Schedule: **set** the values as shown in this screenshot.
8. **Press** the Track button to start reading the input volume and tracking.

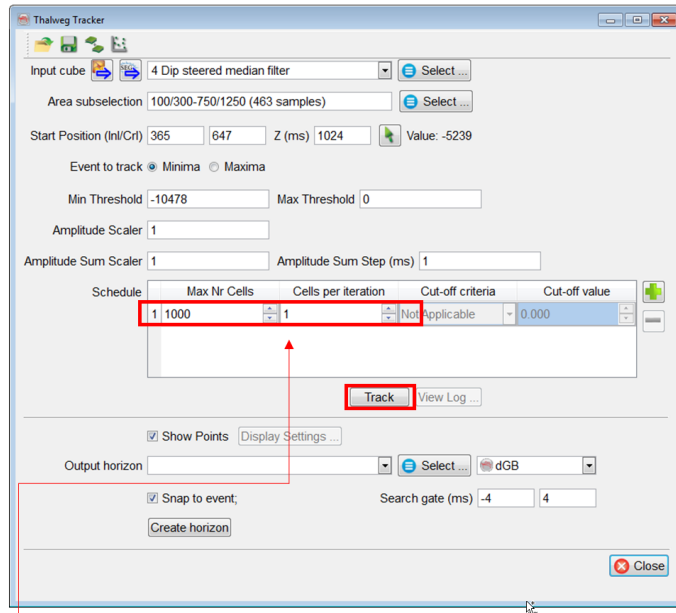

The first row of the schedule table represents the thalweg settings e.g. Max Nr Cells = 1000 and Cells per iteration = 1.

**Workflow cont'd:**

9. Once the processing is finished, it will display the result as color-coded points.

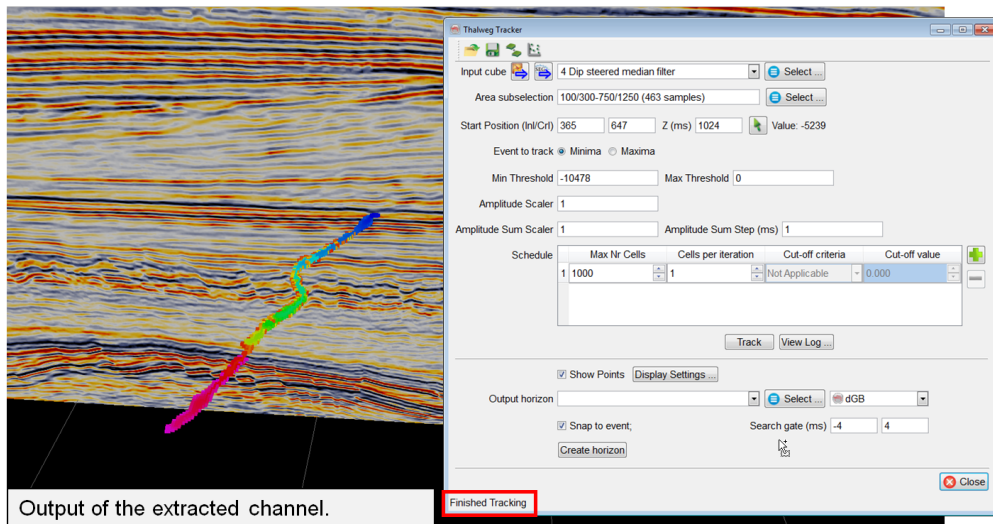



**Workflow cont'd:**

10. If you are satisfied with the results, **specify** the Output horizon name. Optionally, **toggle on** Snap to event, to output a horizon snapped to the nearest Minima or Maxima in a user defined Search gate (default is [-4 +4] ms).

11. **Press** the Create horizon button.

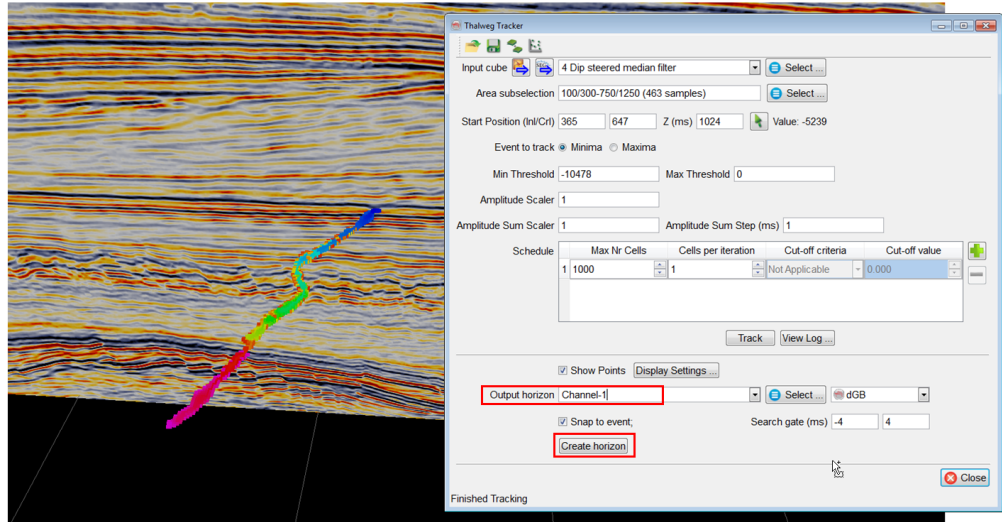

**Workflow cont'd:**

12. The horizon will appear in the tree as well as in the scene.

13. **Turn off** the Show points display.

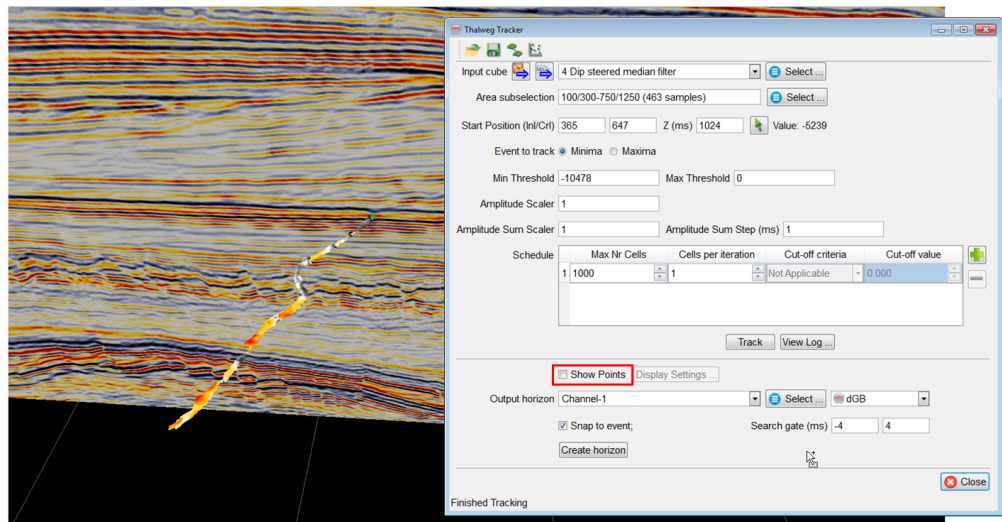
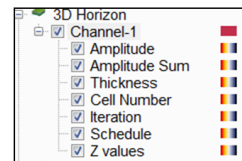

**Workflow cont'd:**

- To track the margins of the channel, **add** a second schedule step and set the parameters as shown in the figure. **Turn on** Show points and **press** the Track button to obtain the Thalweg and its associated margins.

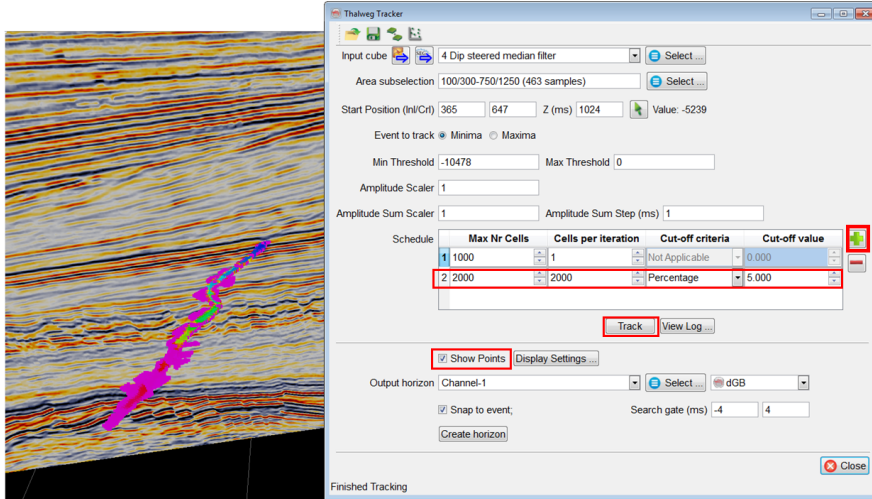

**Workflow cont'd:**

Several horizons can be created and **merged** into a single horizon.

**Crossplot** is a utility to perform analysis on the extracted dataset (e.g. if you use an acoustic impedance (AI) volume, you can analyze iterations with AI data).

**Display Settings** control the display and color coding of the points of various extracted attributes along the Thalweg.

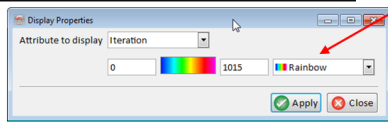
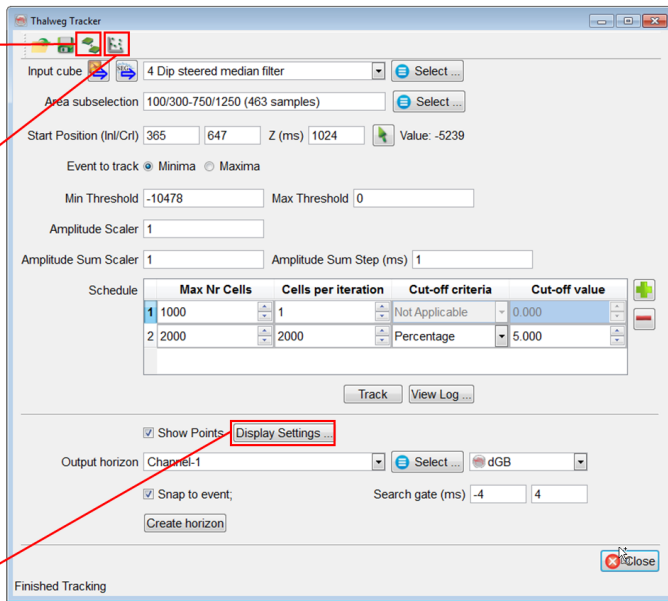

## 2.3.1h Unconformity Tracker

Required licenses: OpendTect Pro, Dip-Steering.

### Exercise objective:

Create two horizons: 1) a seismic event constrained by a few manually picked positions; 2) an unconformable event constrained by well markers.

### Workflow:

1. **Pre-load** the default seismic data set (4 Dip steered median filter).
2. **Add** an in-line (Add Default Data)
3. **Add** the stored Random Line called: "Random Line through wells"
4. **Add** all 4 wells
5. **Go** to 3D Horizon >  
New > Track Unconformity ...

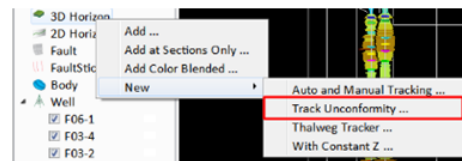

Traditional trackers follow amplitude and phase. Unconformities do not exhibit consistent amplitude / phase behavior and can thus not be tracked with a conventional tracker. The unconformity tracker flattens the dip field using a constrained inversion-based algorithm. Constraints are given in the form of picked positions and (optionally) a confidence weight volume.

### Workflow cont'd:

6. In the Unconformity tracker window, **select** the input steering cube for the tracking: 2. Steering BG Detailed.

Ideally, use a detailed steering cube (see Exercise 2.3.1a) calculated on enhanced seismic.

7. Optionally, **limit** the output extend by using the Volume sub-selection.
8. Optionally, **change** the names of Pickset and Horizon by double clicking on the respective fields.

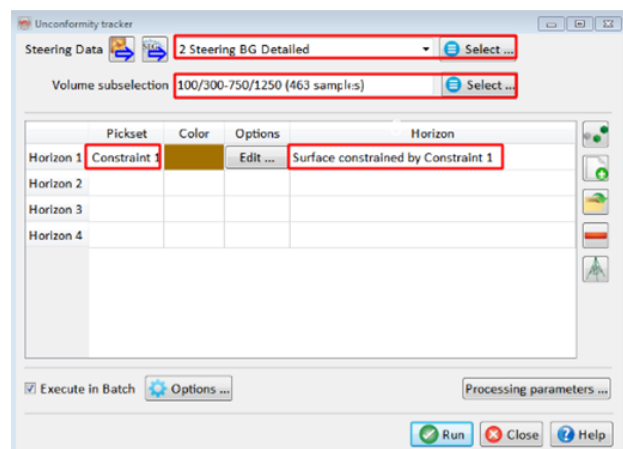

**Workflow cont'd:**

9. **Click** on the Pick Seeds icon  and pick a few points (minimum 3) on the event you want to track.

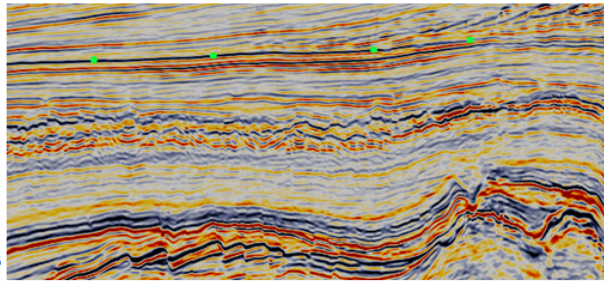

10. Optionally, **pick** more points on in-lines and cross-lines. Alternatively, open an existing pick set with interpreted points by clicking on the corresponding icon: 

11. For the second horizon **press** the wells icon  and select the FS7 marker from all wells.

	Pickset	Color	Options	Horizon
Horizon 1	Constraint 1	<span style="background-color: blue; color: white;"> </span>	Edit ...	Surface constrained by Const
Horizon 2	FS7	<span style="background-color: green; color: white;"> </span>	Edit ...	Surface constrained by FS7
Horizon 3				

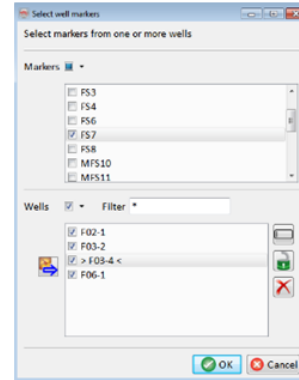

**Workflow cont'd:**

12. **Select** Processing parameters ... and read the information for each of the parameters.\*

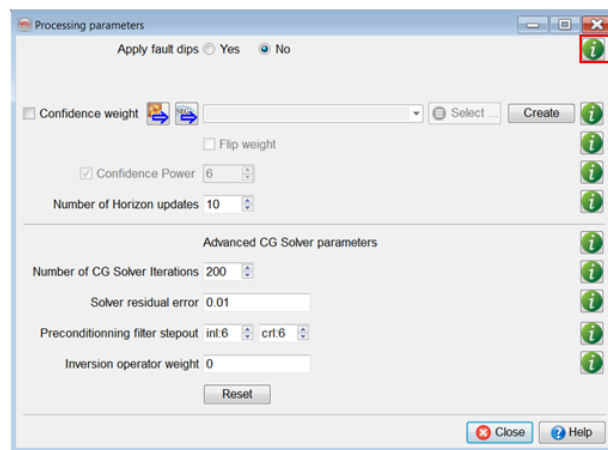

\* A good "Confidence weight" volume example is the Planarity volume.

**Workflow cont'd:**

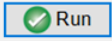
13. **Close** the Processing parameters window and start processing by pressing 

14. When the batch process is finished **Close** the window and **Add** the new horizons to the tree.

15. **Add** a random line to **QC\*** the horizons.

16. Improvements can be made by (if needed): adding more picks; adding a confidence weight volume and by changing the inversion parameters.

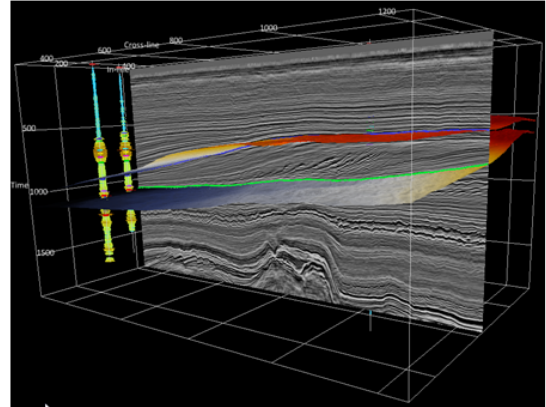

\*Tips: Change the color bar of the random line to grey scale; Show the horizons at sections only; Change the line thickness (Horizon -> Display -> Properties); Move and rotate the random line to check whether the horizon is following the events properly.

## 2.4.3a Well Correlation Panel

Required licenses: OpendTect Pro, Well Correlation Panel, HorizonCube.

### Exercise objective:

Create a well correlation panel and QC the well markers using the seismic data and a HorizonCube to guide you.

### Workflow:

1. **Launch** the Well Correlation Panel (WCP) window: Analysis > Well Correlation Panel, or via the  icon.

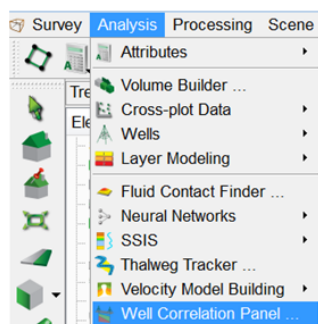

### Workflow cont'd:

2. **Select** data type: 2D line.
3. For Input data, **select** Seis and **select** the line name *Well Correlation-Line*.
4. At the bottom of the window, **select** all four wells available in the list.
5. **Press** OK.

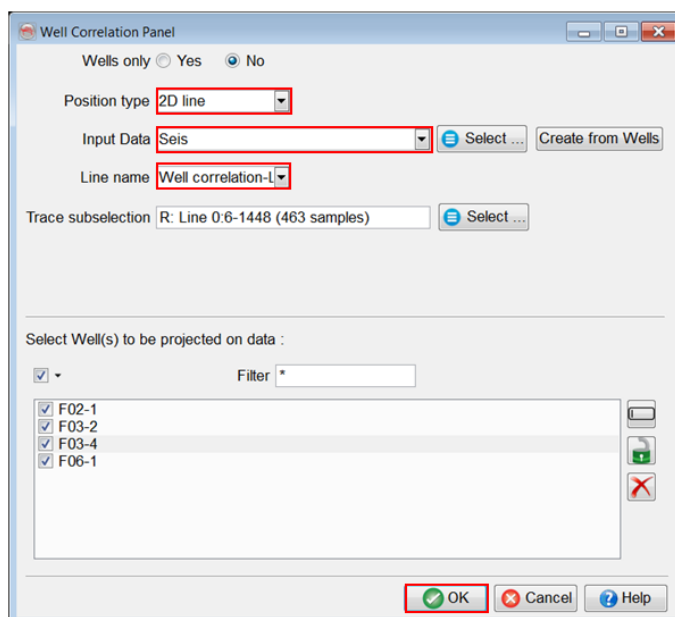

**Workflow cont'd:**

6. **Change** the seismic color spectrum to Grey scale: **click** on VD and from the top bar **spin** the color to Grey scale.

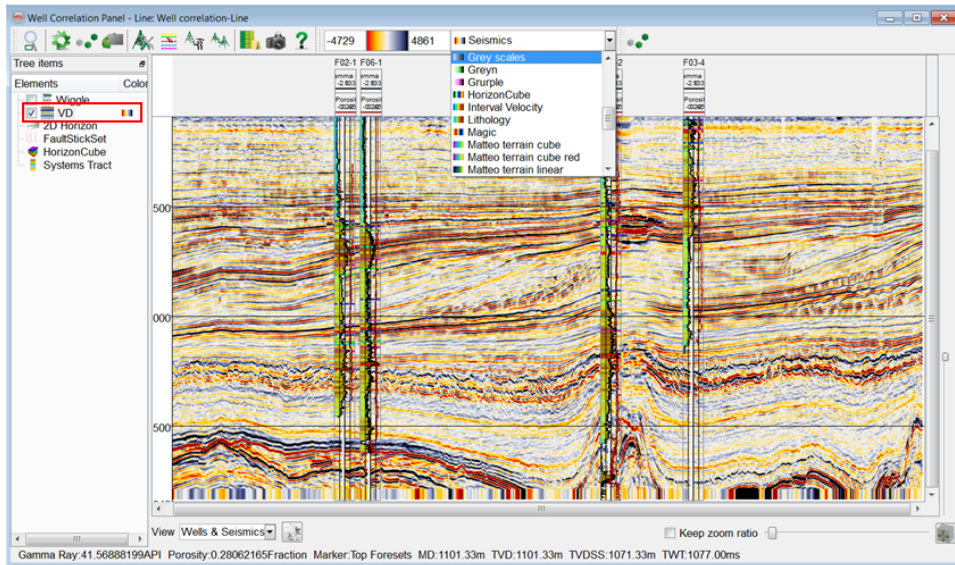

**Workflow cont'd:**

7. **Overlay** the seismic data with the HorizonCube: **right-click** on HorizonCube in the tree and **select** Add Display. **Choose** the 2D HorizonCube "HorizonCube SC-FFT-trunc Random line between wells".

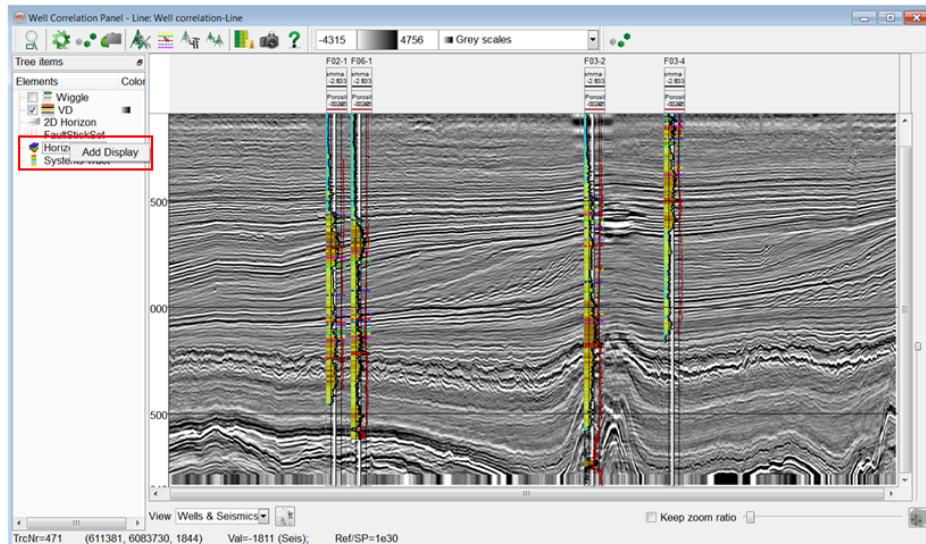

**Workflow cont'd:**

- Now **display** a Gamma Ray (GR) log on all wells: **click** on the well properties icon  from the WCP window.
- In the Log 1 tab, you may **select** Gamma Ray log with a SandShale color bar.

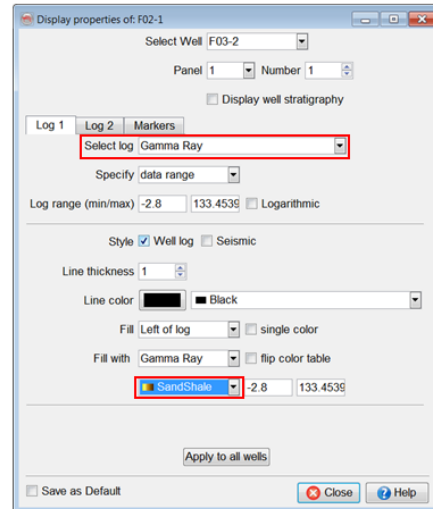
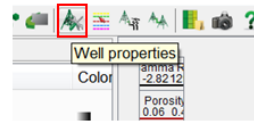

**Workflow cont'd:**

- In the Log 2 tab, leave the log selection to None.
- Press** Apply to all wells to display the Gamma Ray log on all wells displayed in the panel.
- Close** this window.

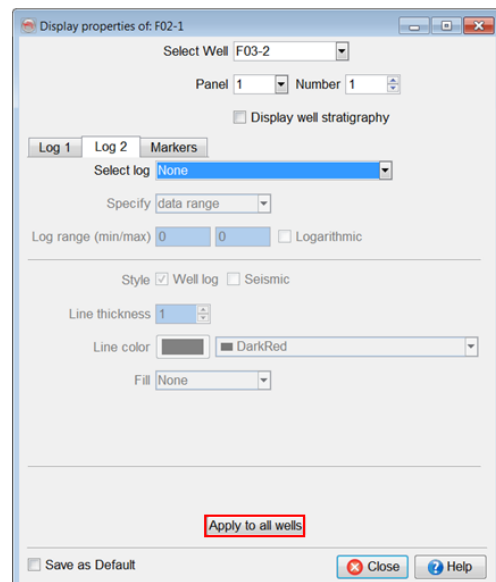



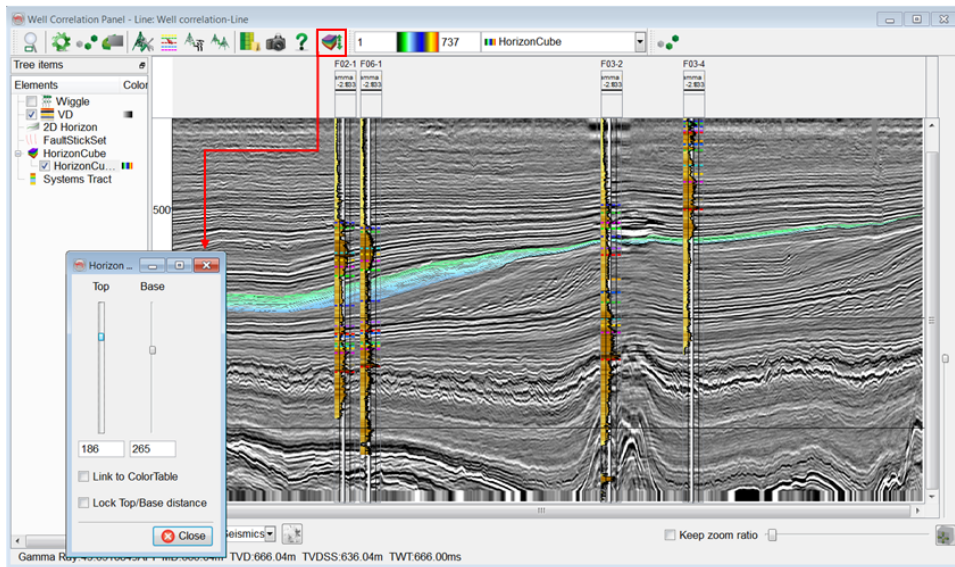

**Workflow cont'd:**

- 13. Now **start** interpreting the depositional trends and possible systems tracts boundaries by **moving** the HorizonCube slider  up and down.



**Workflow cont'd:**

- 14. To edit the markers: **click** on the  icon.
- 15. **Add** a new defined boundary as a marker by clicking on .  
In the pop-up dialog, **give** a new name and color to the new marker and **click** Ok.

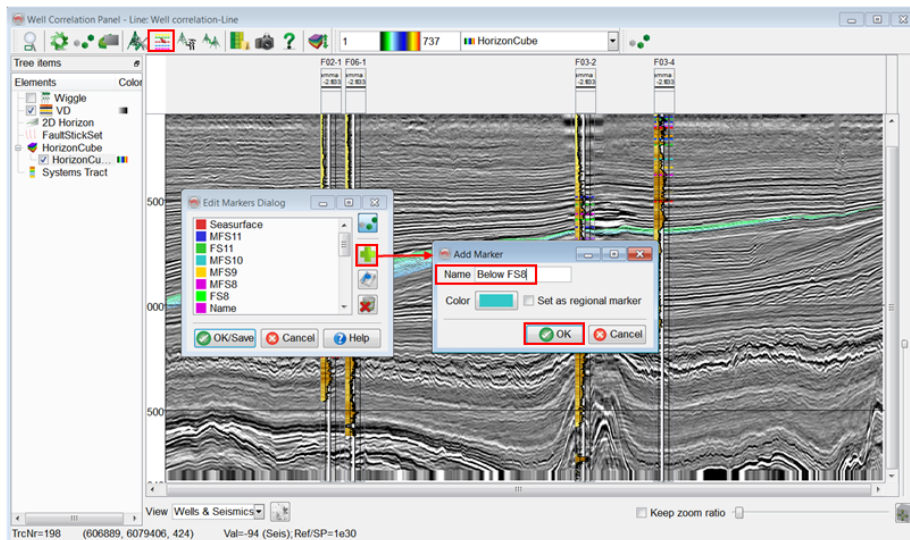

**Workflow cont'd:**

16. Once the marker is added in the list, it will become an active marker: **click** in the well area to add a marker. To **delete** a marker, use CTRL + mouse click on the marker.
17. When done with the marker interpretation, **press** Ok/Save button in the markers dialog.

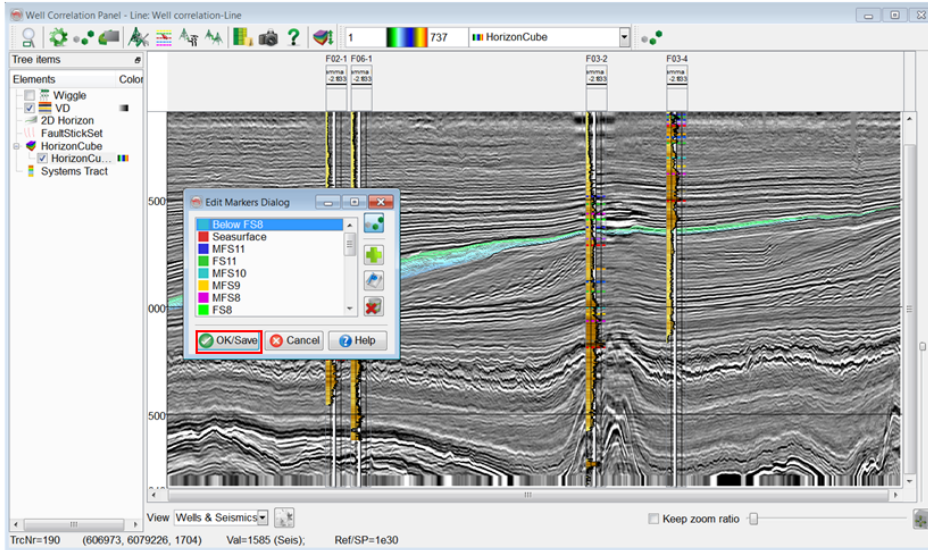

## 1.4.4b Grid Stacking Velocities

Required licenses: OpendTect.

### Exercise objective:

Specify the gridding workflow to grid the stacking velocity functions.

### Workflow:

1. **Launch** the volume builder module accessible from the icon .
2. **Select** the Velocity gridder step and **add** it to the Used steps list with the middle arrow.

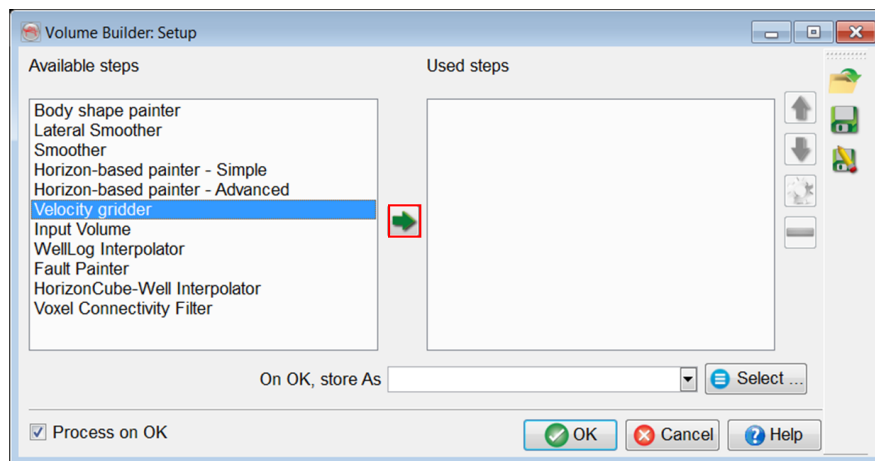

### Workflow cont'd:

3. In the following window, **choose** Triangulation as an algorithm type.
4. **Add** velocity source.

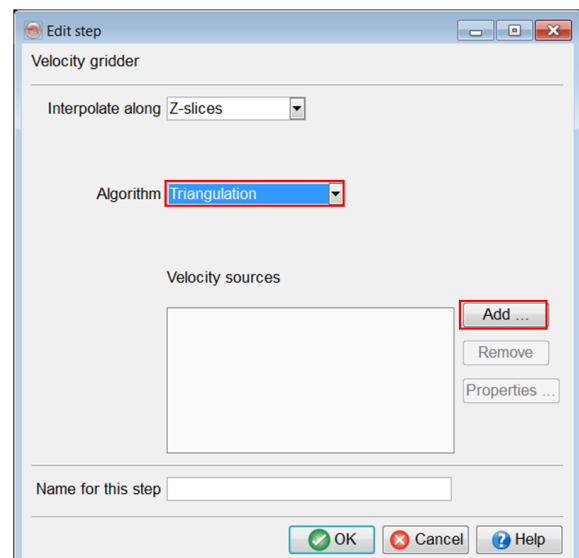

**Workflow cont'd:**

5. **Choose** Type: Stored Functions and select the input function *Vrms\_function* that was imported in the previous exercise.
6. **Click OK** to proceed.

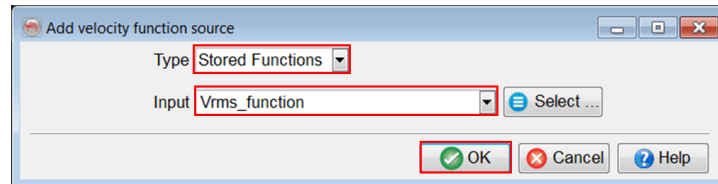

**Workflow cont'd:**

7. **Name** this step (e.g. *Triangulation of Vrms function*).
8. **Click OK**.

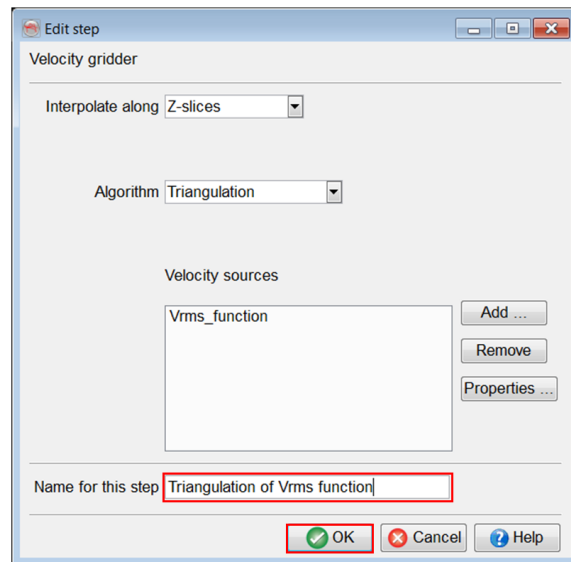

**Workflow cont'd:**

9. **Store** the setup as *Grid velocity function*.
10. **Toggle off** Process on OK and **press** OK.

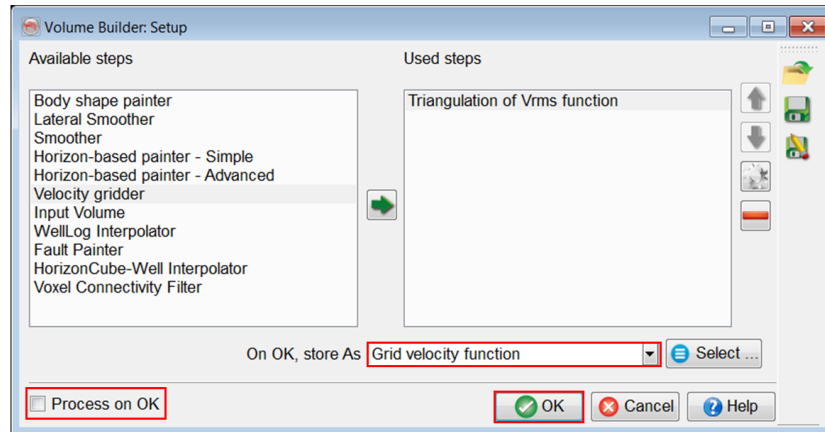

**Workflow cont'd:**

11. **Add** default inline to the scene.

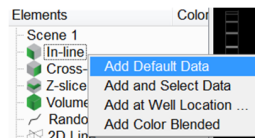

12. **Right-click** on it > Add > Volume Builder Attribute.

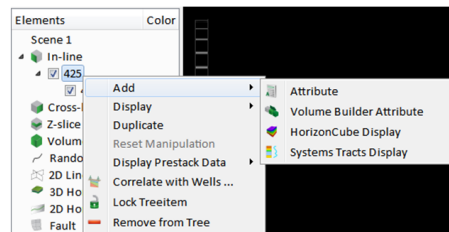

13. **Select** *Grid velocity function* and **press** OK to display the attribute on-the fly.

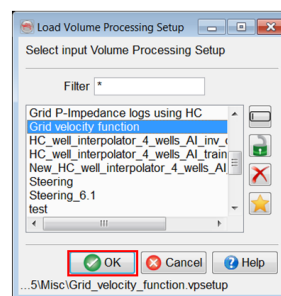

Workflow cont'd:

The result should be similar to the one shown below

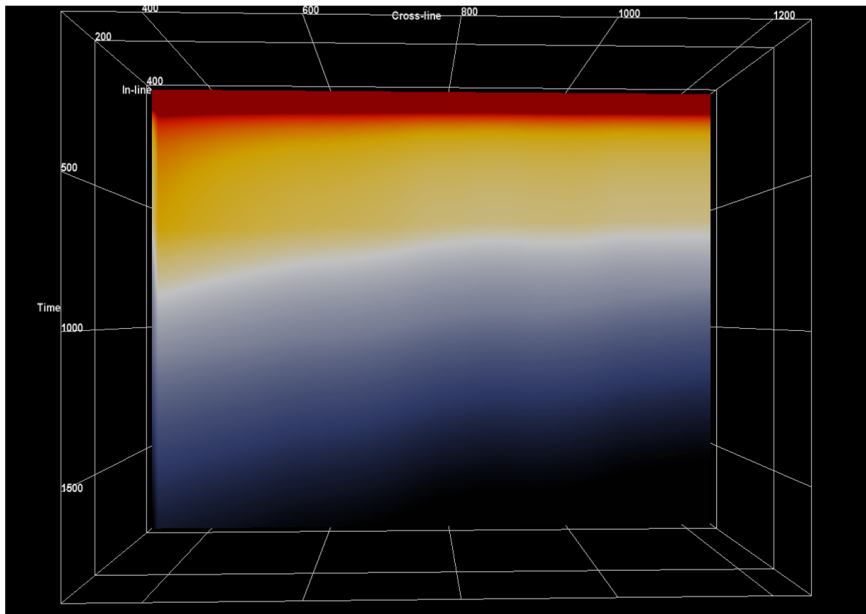

Workflow cont'd:

14. Go to Processing > Create Seismic Output > Volume Builder.

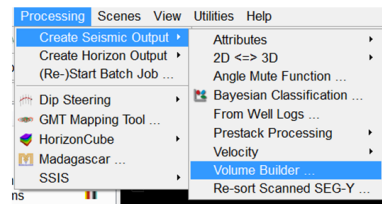

15. In the pop up window, select *Grid Velocity function* for Volume Builder setup and specify an output name, e.g. *Vrms*, and press OK to start batch processing.

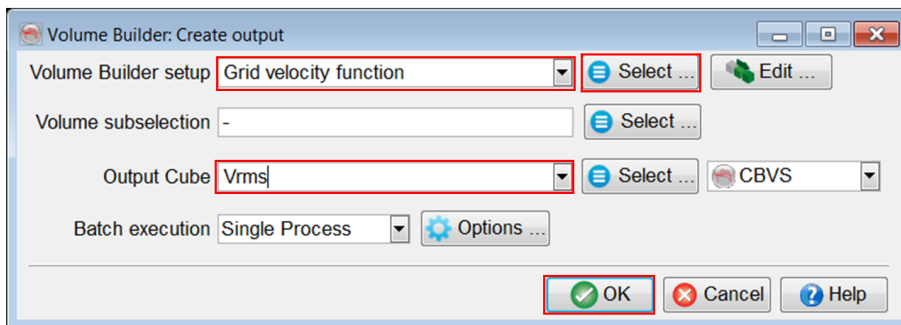

## 1.4.4c TD Conversion On-the-fly

Required licenses: *OpenTect*.

### Exercise objective:

Create a depth scene and perform velocity conversion.

### Workflow:

1. **Go to** Scenes > New [Depth].

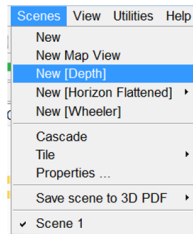

2. A window pops-up asking you to select or create a velocity model. **Click on** Edit...

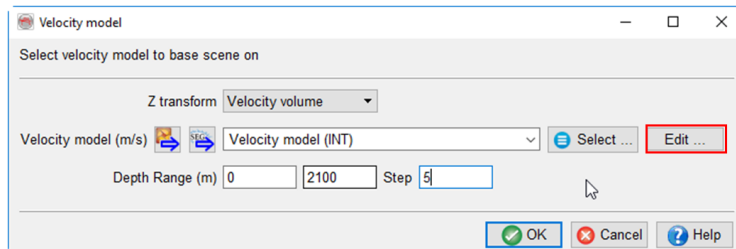

### Workflow cont'd:

3. **Select** the velocity cube i.e. *Velocity model (RMS)* and **specify** the velocity type (RMS).
4. **Press** OK and OpenTect will scan the file to compute the depth range for the new scene.
5. **Press** OK in the Velocity Model window and a new depth scene will appear.

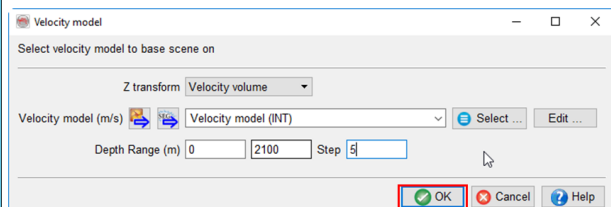
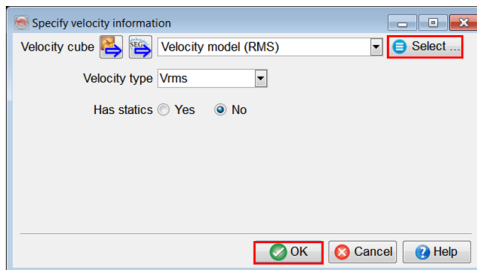

## Workflow cont'd:

- In the depth scene, **display** any stored volume on the inline 425. You will notice that the scene now shows data in depth, which has been converted from time data using the interval velocity you, selected. This is done on-the-fly.

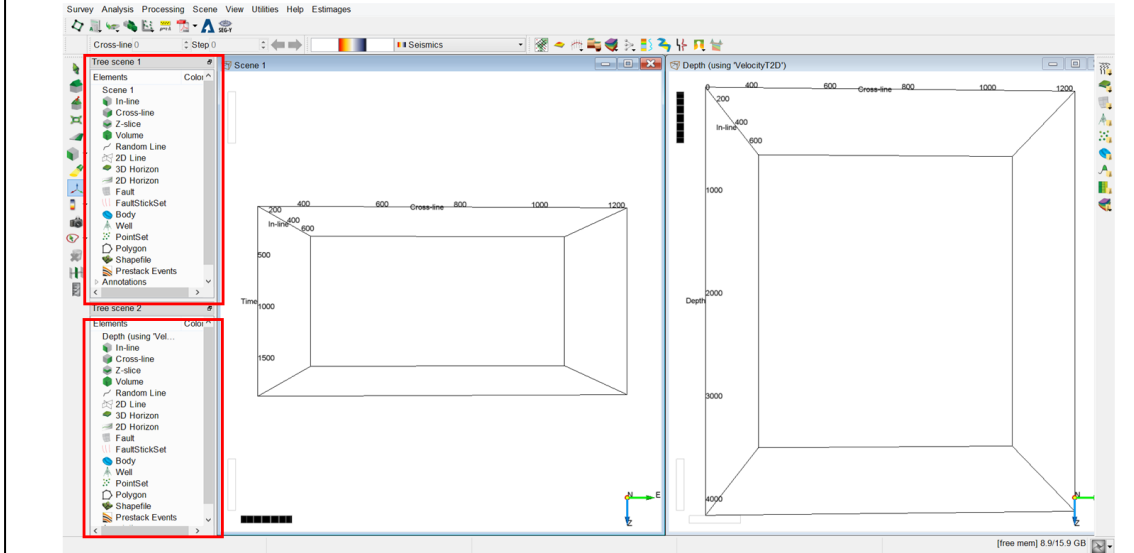

## Workflow cont'd:

### Conversion of Vrms to Vint

- Go to** Processing > Create Seismic output > Velocity > Velocity conversion...

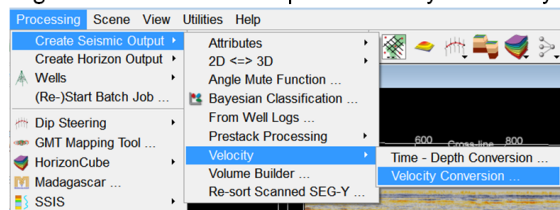

- Fill** the fields as shown below and **click** OK.

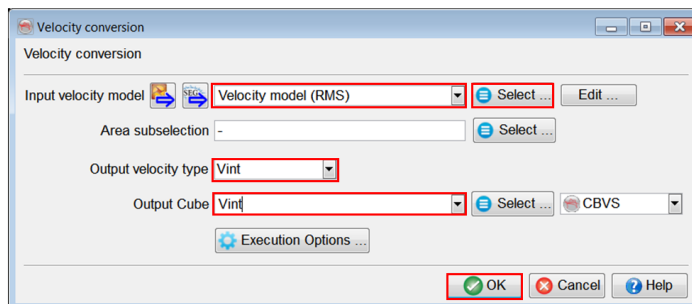



**Workflow cont'd:**

9. **Right-click** on an inline in the scene > Add and Select Data.

10. **Select** the new converted interval velocity.

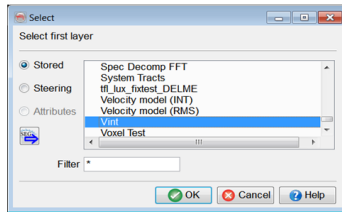
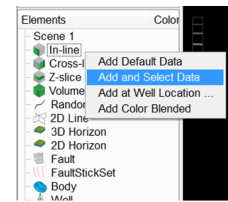

11. **Right-click** on an inline 425 in the scene > Add > Attribute.

12. **Select** the rms velocity to compare.

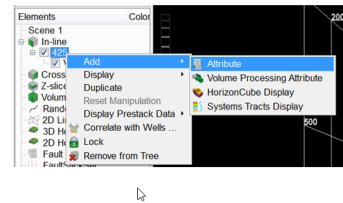
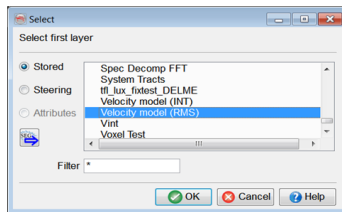

**Workflow cont'd:**

Velocity model (RMS)

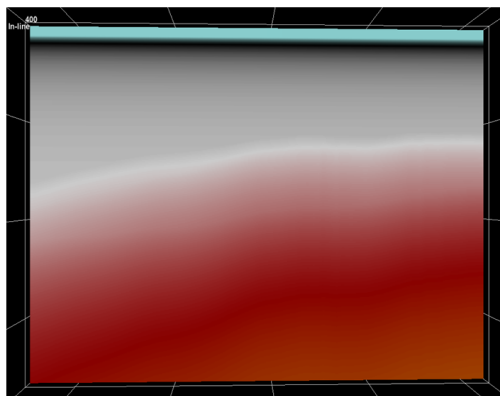

Velocity model (INT)

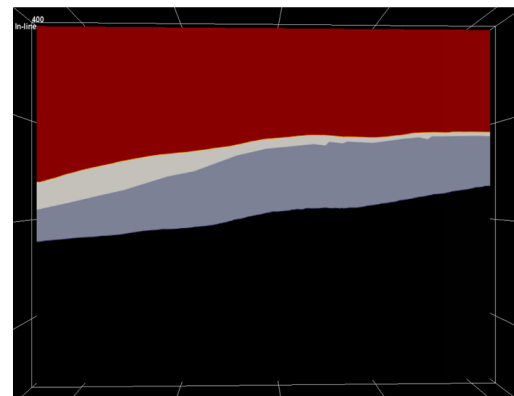

## 1.4.4d TD Volume Conversion In Batch

Required licenses: OpendTect.

### Exercise objective:

Use the velocity volume to time-depth convert volumes in batch mode.

### Workflow:

1. **Launch** the time-depth conversion dialog.

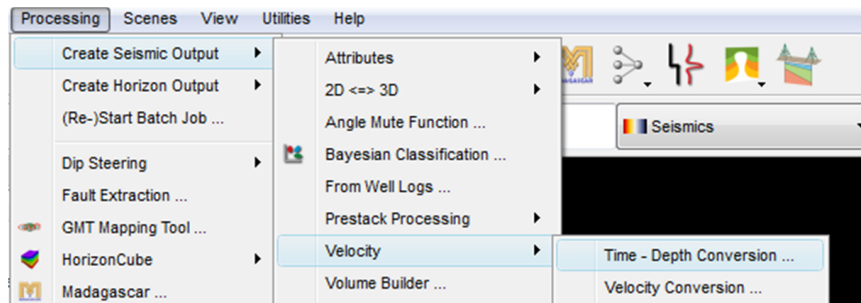

In general, the depth volume does not change laterally from the original cube (thus InL/XL step stays the same) but the depth Z range can be larger.

### Workflow cont'd:

2. **Select** the Velocity Model (in this case, Velocity Model (INT)).
3. **Define** the depth range and the step
4. **Select** the Time volume to be converted

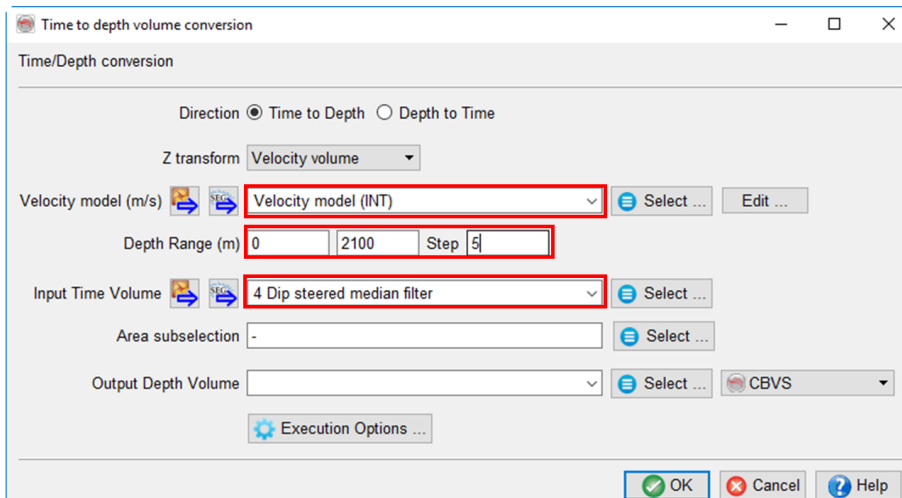

**Workflow cont'd:**

5. **Specify** the new output depth volume (e.g. D-4\_DSMF).
6. **Click** on OK. The volume will be saved in depth and stored in the time survey

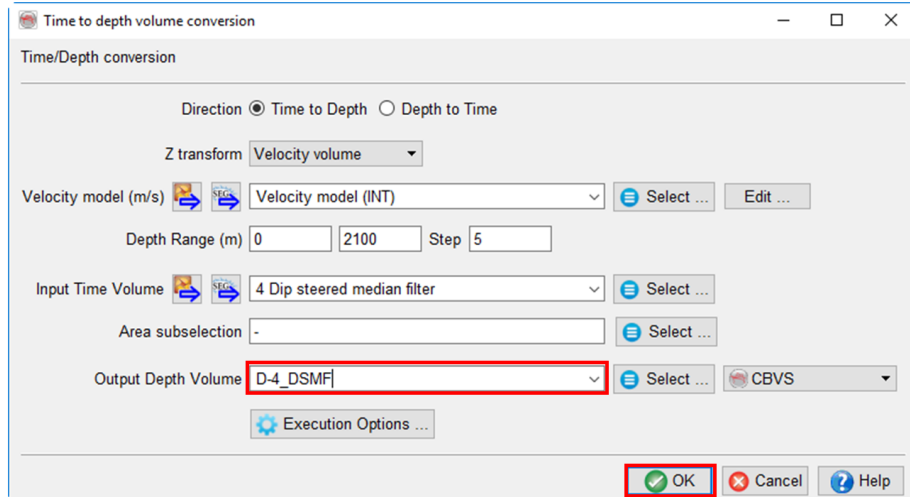

**Workflow cont'd:**

7. To **display** the new depth volume, go to the depth scene. **Click** on the scenes, **Select** New [Depth].
8. A new window will pop up, **Make** sure all inputs are correct, and then **Press** Ok.

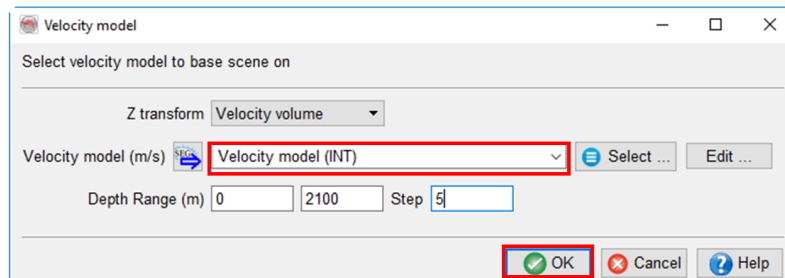

**Workflow cont'd:**

9. Right click on inline > Add and Select data
10. In the pop-up dialog, **Select** the depth volume.
11. **Hit** Ok, and a new depth volume will be displayed

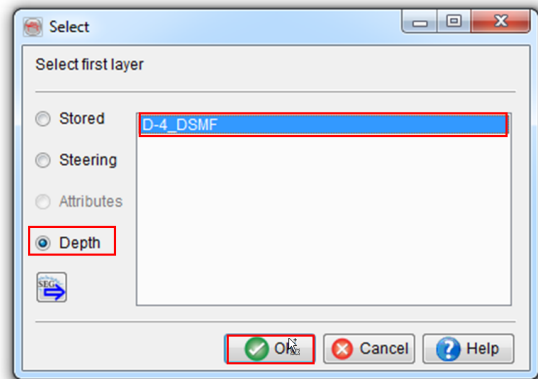
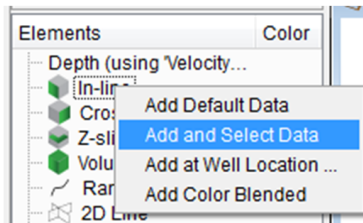

---

## 1.5.1a Bright Spot

Required licenses: OpendTect.

### Exercise objective:

Isolate an amplitude anomaly (bright-spot) using attribute analysis and visualize the anomaly in 3D using volume rendering

### Workflow:

1. **Launch** the attribute set window: **click** on the Attribute 3D icon  and **select** 3D.
2. **Define** the Energy attribute with default parameters.

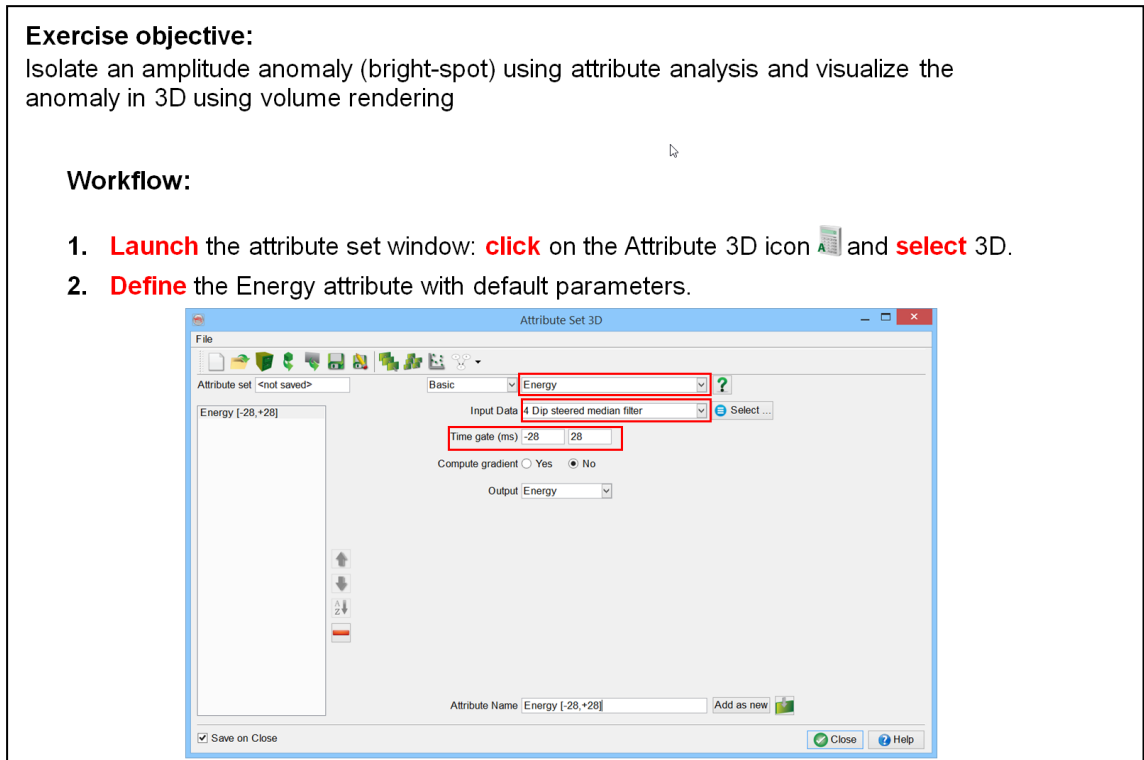

**Workflow cont'd:**

3. **Provide** an attribute name as Energy [-28,+28] and **press** Add as new.

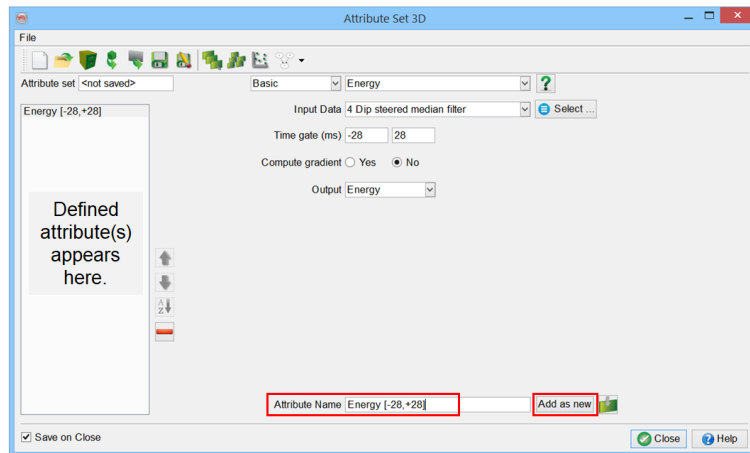

There are no restrictions on the length of the name: it may contain spaces. It is recommended to use a name that contains all essential information of the attribute. It helps you remember what this attribute does, and prevents having to go back to this attribute window to see the exact definition of the attribute.

**Workflow cont'd:**

4. **Tick** the Save on Close box and **press** Close.  
Alternatively, **press** the Save as icon  and **press** Close.
5. **Provide** a (new) name for the attribute set like *my first attribute set* and **press** OK.

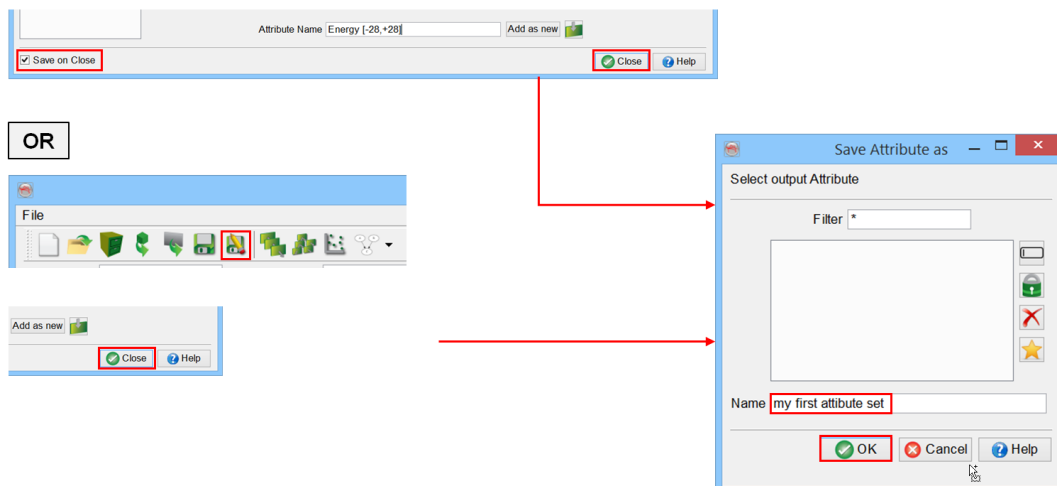

**Workflow cont'd:**

6. In the tree, **right-click** on In-line and **select** Add Default Data.
7. **Change** the inline position to 250: **select** the inline in the tree and **type** the position using the position toolbar.
8. **Add** an extra attribute layer to inline 250: **right-click** on the inline number in the tree and **go** Add > Attribute.
9. The attributes available are organized in three categories: Stored, Steering and Attributes (from the active attribute set and calculated on-the-fly). **Go** to the Attributes section, **select** your attribute *Energy [-28,+28]* and **click** Ok.

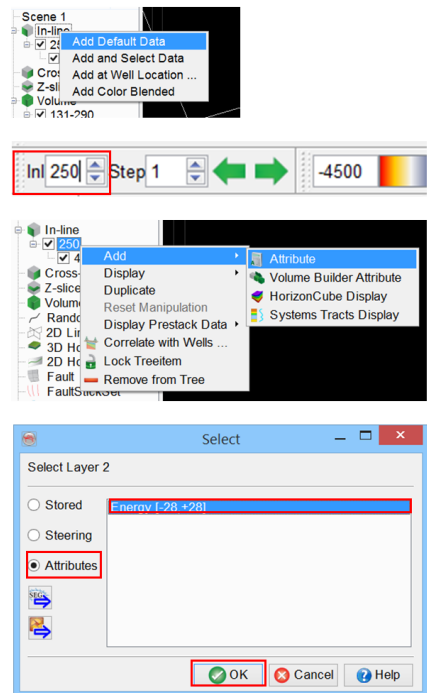

**Workflow cont'd:**

Results should look like this.

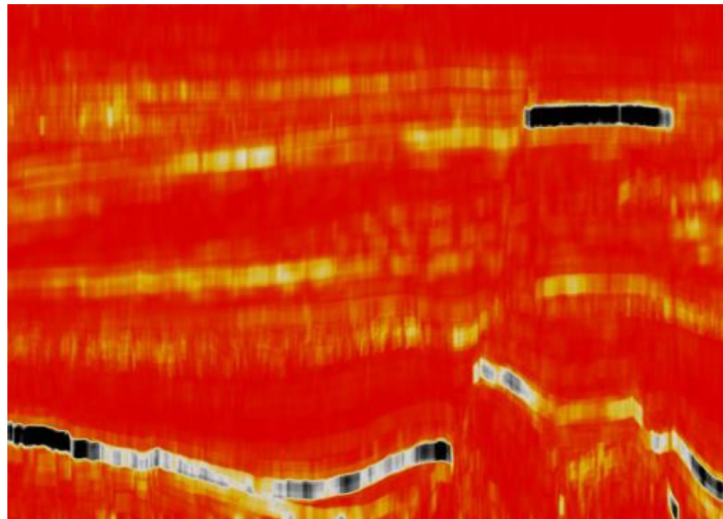

## Workflow cont'd:

### Color-bar

Visualizing the results is almost as important as the results themselves. Therefore, try different color-bars for your attribute. Each attribute layer has its own color-bar. The color-bar is displayed by default above the 3D scene and can be edited by selecting a new color-scheme.

1. **Click** on the attribute from the tree and **change** the color-bar.  
**Try:** Chimney, Faults and Grey scales.

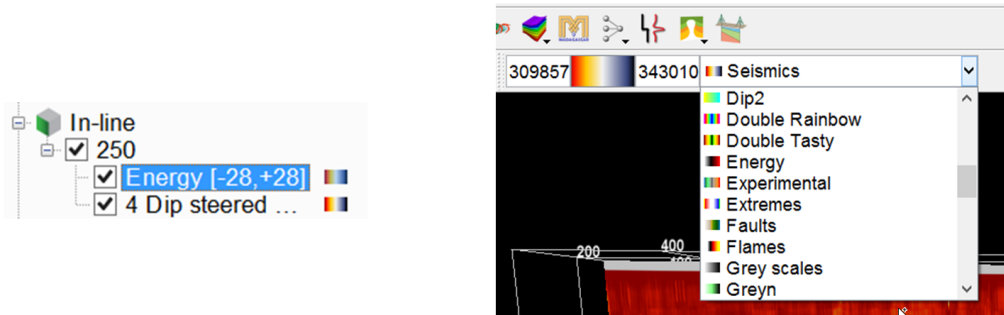

## Workflow cont'd:

2. **Right-click** on the color bar: **select** Manage...

### Edit color markers

*from the main window*

The color can be edited by double clicking on one black marker below the histogram. To add a new marker, double click at the position you want, select the appropriate color and click Ok. Drag the marker to change its position. Right-click on a marker and chose Remove color to delete it.

*From the table*

Right-click in the white section of the color-bar displayed under the histogram and chose Edit markers... In the table that pops up, the colors and position of every marker can be edited: for a specific marker, you can type in a new position and change the color by double-clicking on the used color. When right-clicking on a marker, you can either delete the selected marker or add a new one above or below.

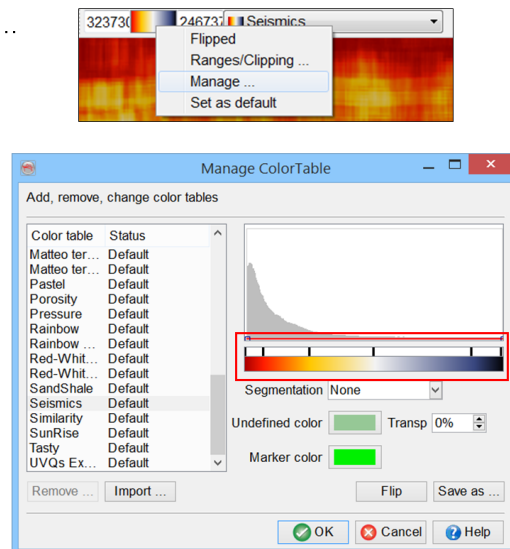



## Workflow cont'd:

### Segmented vs Continuous

The color-bar can be continuous or segmented. When changing the Segmentation from None to fixed, you define the number of the segment. Segmented color-bars are in particular used when displaying a discrete attribute, for example a Neural Network result: one color corresponding to one class.

### Transparency

The red line in the histogram represents the transparency: changing the transparency line alters the parts of the spectrum that are displayed. Drag the seeds up to modify the transparency. You need to have a seed at each extremity of the histogram: add new seeds by double-clicking on the red line and drag the seed laterally and vertically. To remove a seed, do ctrl+click on the seed.

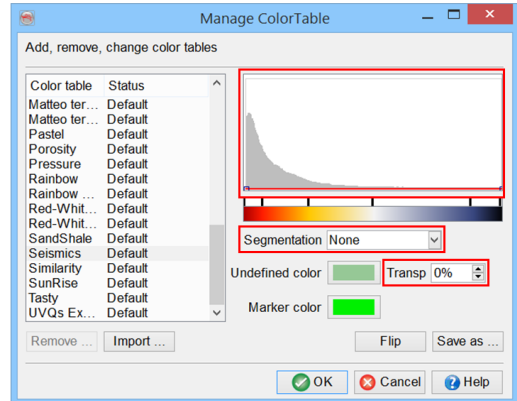

## Workflow cont'd:

3. **Press** Cancel to close the color-bar manager.

The undefined color is the color that will be used for undefined values. You can adjust its transparency.

The changes you are making are applied in the same time in your scene: you can actually QC the color-bar edition.

Once you are done with the color-bar editing, you can save it with another name or overwrite the color-bar you were using (not recommended) by just clicking OK and Continue. If you do not wish to save the modifications, click on Cancel.

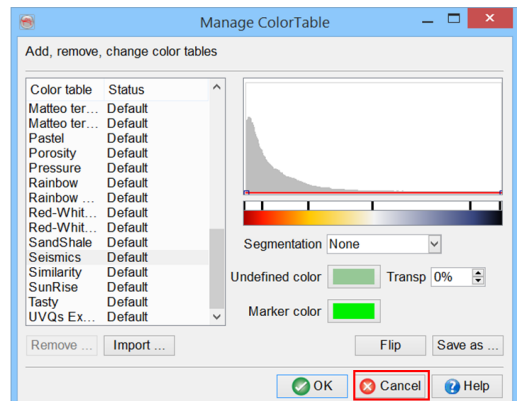

### Workflow cont'd:

4. **Right-click** on the color-bar and **select** Set as default: it will set the specific color bar by default for all the attributes to be displayed that do not have a specific color bar attached to them.

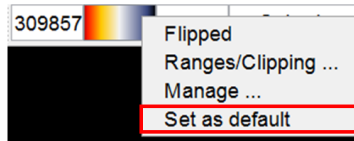

5. Optionally, **right-click** on a stored attribute (volume) in the tree and **select** Save Color Settings to save the color-bar and the color range: it will be used when loading this specific attribute again.

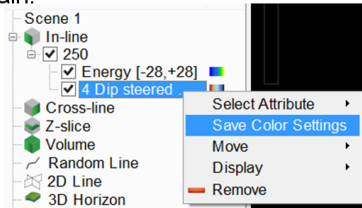



The color-bar right-click menu allows you to flip the color bar, change the Ranges/Clipping (to set the scaling values symmetrical around zero), Manage the color bar, Set as default.

### Workflow cont'd:

#### Evaluate attribute parameters

Now we are going to evaluate the Time gate parameter of the energy attribute by interactively (movie-style) evaluating its parameter settings:

1. **Open** the Attribute Set window: **click** on the Attribute set icon  and **select** 3D.
2. **Activate** the *Energy [-28,+28]* attribute displayed on inline 250 in the tree.
3. In the Attribute Set window, **select** the *Energy* attribute again and **press** the Evaluate attribute icon .

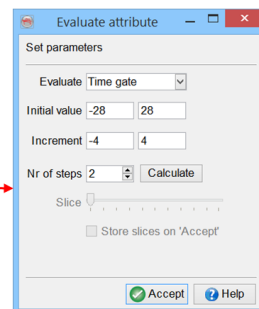
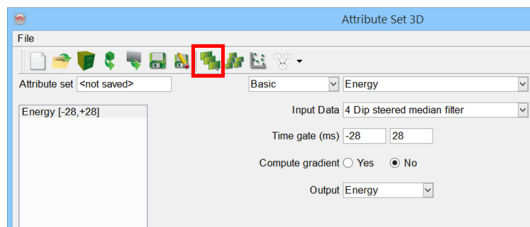
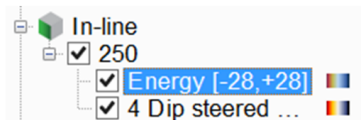

**Workflow cont'd:**

- Select** the parameter to evaluate: Time gate (in this case, there is only one type of parameter to evaluate so it is selected by default).
- Provide** the parameters for the time gate as shown in the image on the right.
- Press** the Calculate button.
- The slider becomes active once the on-the-fly processing is finished.  
**Move** the slider to see the results for a certain slider position, corresponding to a time gate in this case: **observe** the changes in the 3D scene (see the following slides, for instance).

If an attribute is defined using a time gate and/or a step out, these parameters can be evaluated the same way.

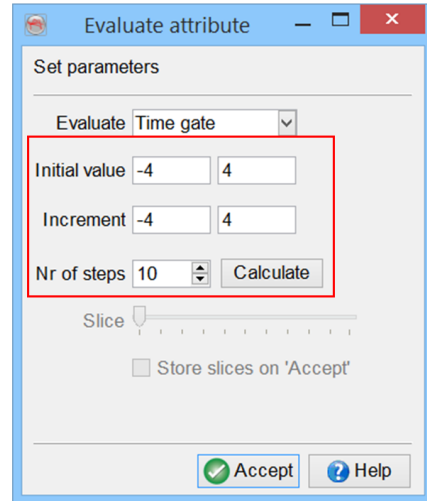

**Workflow cont'd:**

- Evaluate** the attribute by moving the slider position.

*Time gate [-8, +8]ms*

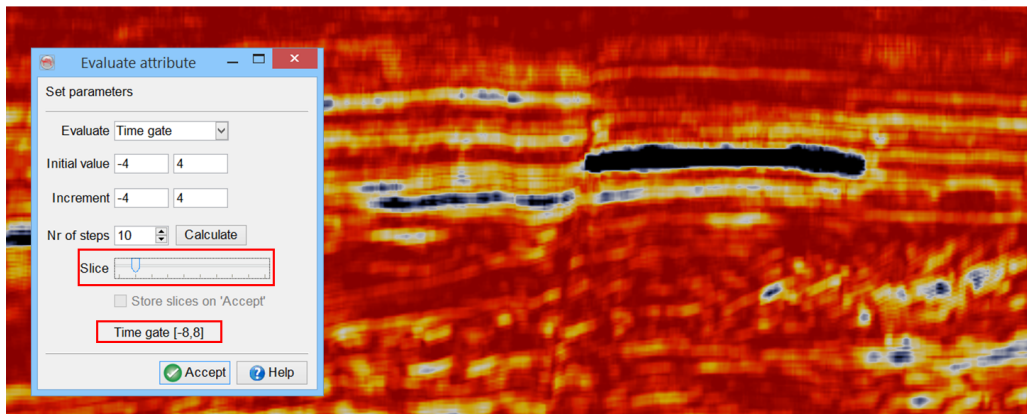

Workflow cont'd:

*Time gate [-20,+20]ms*

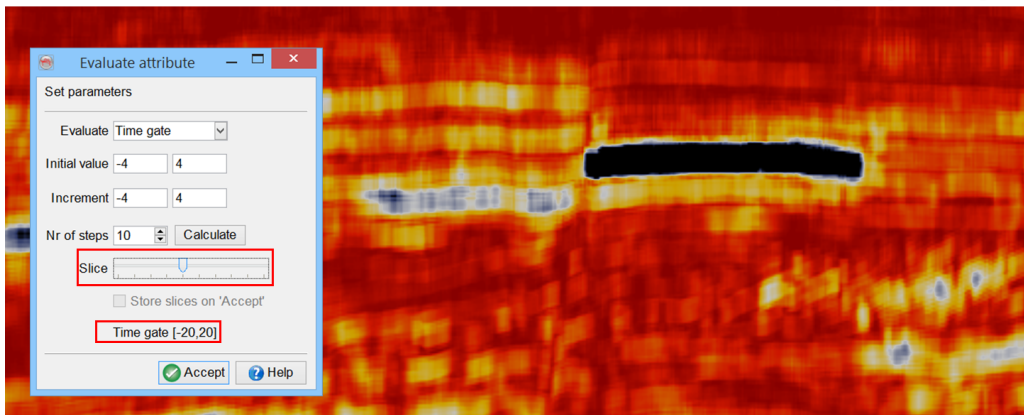

Workflow cont'd:

*Time gate [-36,+36]ms*

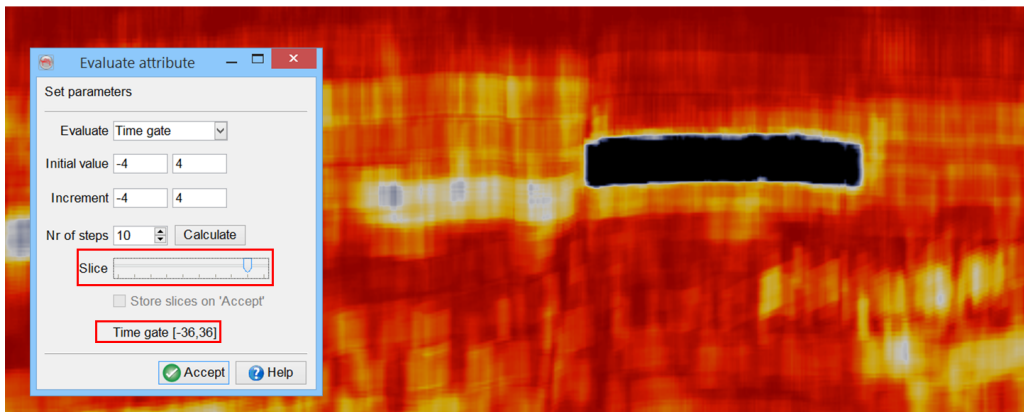

If you Accept at this point, [-36,36]ms will become the time gate of the attribute that you were evaluating. In this manner, you decide the optimum time gate.  
You may also say that this might be a too large time gate for this feature when compared with a narrow time gate e.g. [-16,16]ms.

### Workflow cont'd:

- Once the best time gate has been decided, **press** Accept to update the attribute with the selected time gate.
- Update** the attribute name according to the selected time gate
- Optionally, **click** on the  icon to save the attribute set window or **tick** the Save on close box, and **close** the window.

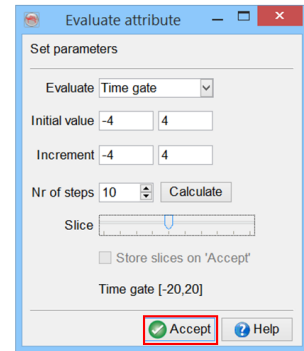

### Workflow cont'd:

#### Create a seismic output

So far, everything was done in memory. We are now going to calculate and store the Energy attribute on disk as an OpenText volume.

- Click** on the Create Seismic Output icon  and **select** 3D or **go to** Processing > Create > Seismic Output > Attribute > Single Attribute > 3D

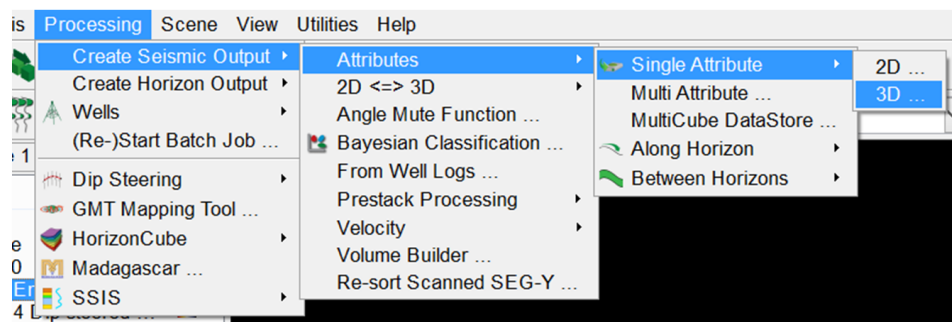

### Workflow cont'd:

2. **Select** Energy as the Quantity to output.
3. **Select** a volume sub-selection:  
Inline range: 100 – 300, Crossline range: 900 – 1150, Time range: 432 - 600 ms  
**Press** OK.
4. **Press** OK to start the processing.

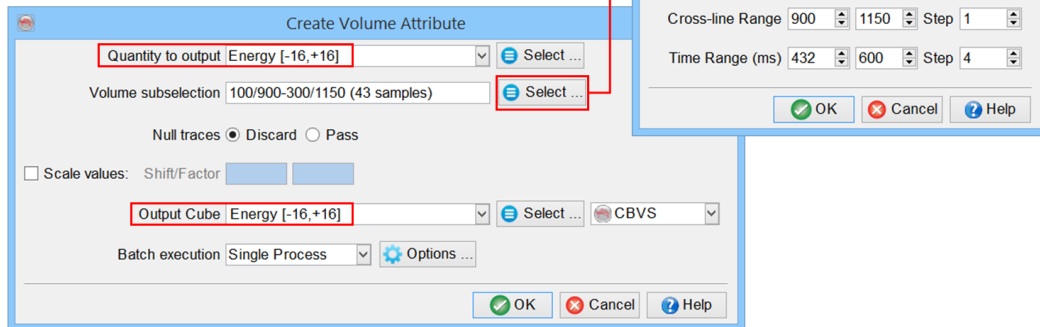

By default the processing is single-machine, To speed up, you can use the multi-machine processing (requires plugin).

### Workflow cont'd:

#### Volume Rendering

The objective of the last step of this exercise is to fully visualize the bright-spot in 3D.

1. **Right-click** on Volume and **Add**. It will insert an empty volume in the tree which is centrally positioned in the scene.
2. **Position** the volume: **Right-click** on <343-506 / 656-893 / 692-1156> and **go to** Display > Position.

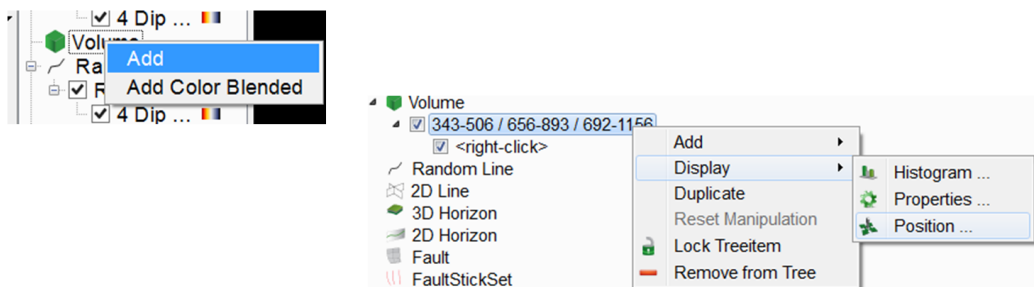

**Workflow cont'd:**

- It will launch a position dialog: **fill in** the ranges:  
Inline range: 100 – 300, Crossline range 900 – 1150, Time range: 432 – 600ms.  
**Press** OK.
- Select** Energy from the window in the Stored category and **Press** OK again.

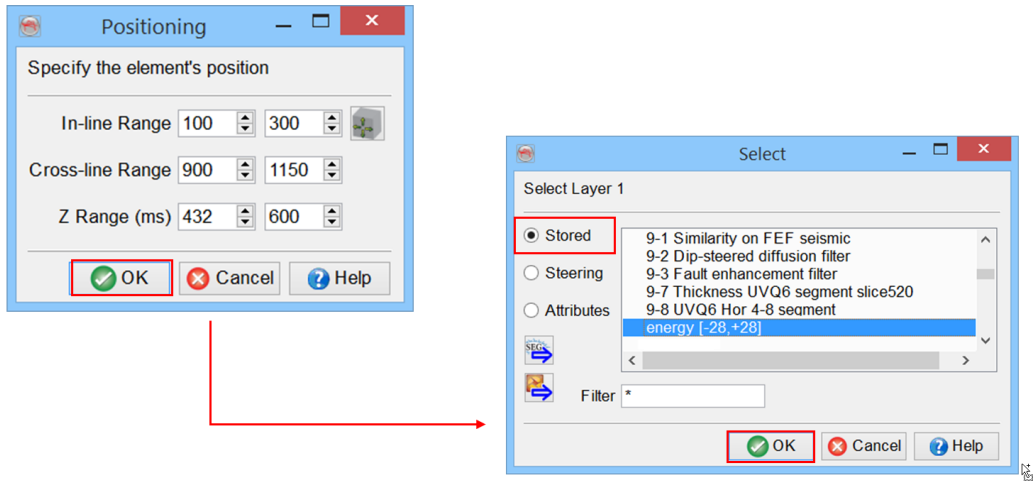

**Workflow cont'd:**

- Change** the color-bar to Chimney and optionally **adjust** the color range.



- In Position mode, **left-click** (keep pressed) and **drag** to re-position the surfaces of the volume or just **scroll** through in this manner to view the contents.

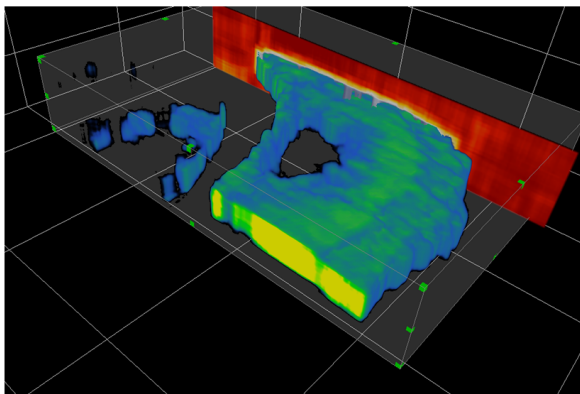

Attributes calculated on the fly can be displayed using the volume rendering. For large volumes, it is recommended to store them prior displaying to save time.

## 1.5.2a Spectral Decomposition

Required licenses: OpendTect.

### Exercise objective:

Study paleo-geomorphological features by displaying 3 iso-frequencies simultaneously with color stacking.

### Workflow:

1. **Right-click** on 3D Horizon in the tree and **click on** Add color blended...  
**Choose** horizon *Demo 1->MFS4* from the list of horizons.
2. Optionally, to speed up the exercise, **click** Select for area sub-selection and **set** inline range to 200-650; crossline range to 500-1000.  
**Press** OK to apply the changes and then **click** OK to display the horizon.

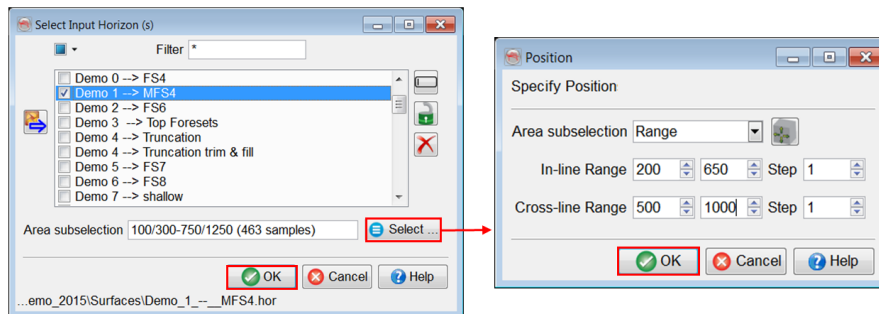
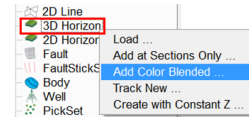

### Workflow cont'd:

In the tree, the horizon appears with 4 separate attribute layers. The three lowest attribute layers represent the RGB channels (see color flags next to each layer). Three attributes can thus be blended into a single display.

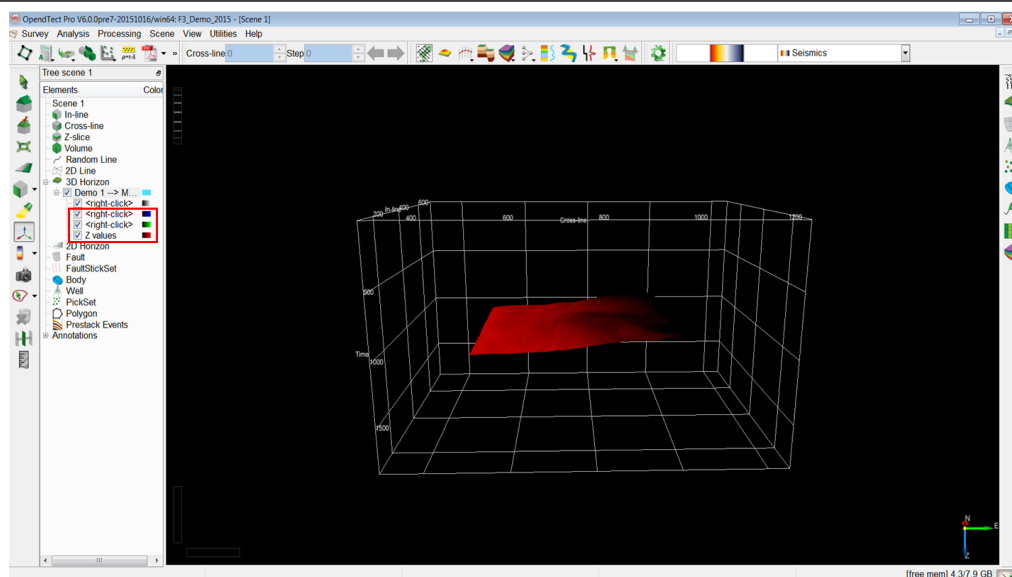



**Workflow cont'd:**

3. To define 3 different attributes that will be loaded to the RGB channels of the horizon, **open** an attribute set 3D: **click** on the  icon.
4. **Select** Spectral Decomposition as attribute and **set** the time gate to [-8,24]ms.

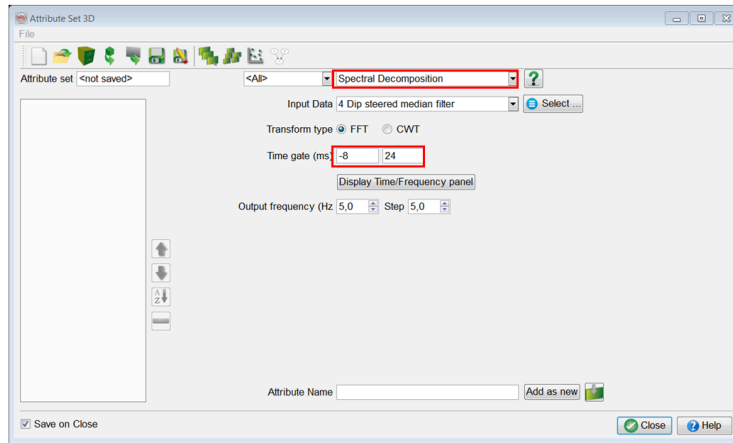

When the extraction of an attribute is done on a horizon, choosing the right time gate is critical. The time gate represents the interval of investigation. If a symmetrical time gate is chosen (e.g. [-28, +28ms]) the attribute will highlight geological features above and below the horizon. When an asymmetrical time gate is chosen (e.g. [-8, 24ms] or [-24, 8ms]) the attribute response will highlight geological features below or above the horizon.

**Workflow cont'd:**

5. **Right-click** on Inline in the tree > Add Default Data  
Inline 425 will be added to the scene.
6. **Reduce** Z ranges of the section, so that it just covers the horizon interval: **select** the inline and **drag** the green anchor vertically.
7. **Right-click** on the 4 Dip Steered Median Filter attribute and **select** Display > Amplitude Spectrum...

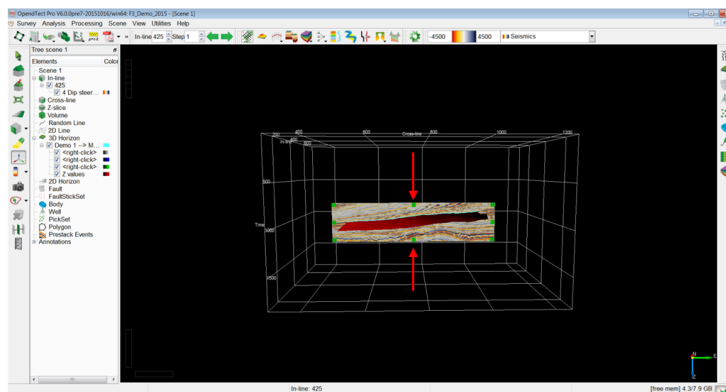
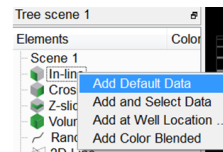

### Workflow cont'd:

8. Within the amplitude spectrum, **identify** the frequencies to be used as the low, middle and high frequencies: the low frequency can be selected as being the first peak (e.g. 24Hz), while the high frequency as the last peak (e.g. 64 Hz). After choosing the frequencies, **close** Amplitude spectrum window.

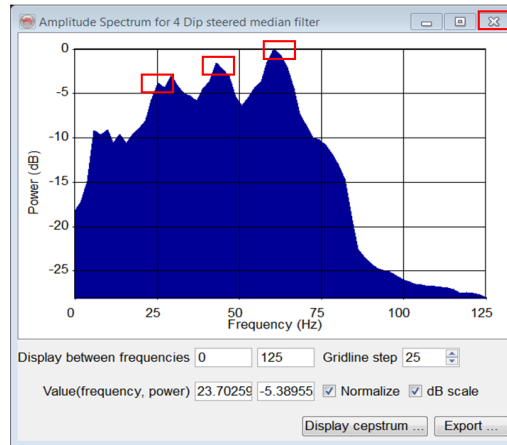

### Workflow cont'd:

9. Back to the attribute set window: **create** the first Spectral Decomposition attribute and **set** the input data to *4 Dip Steered Median Filter*.
10. **Set** output frequency to 24Hz with a step of 4Hz.
11. **Give** a name to a new attribute, e.g. *SD\_24Hz[-8,24ms]*, and **press** Add as new.

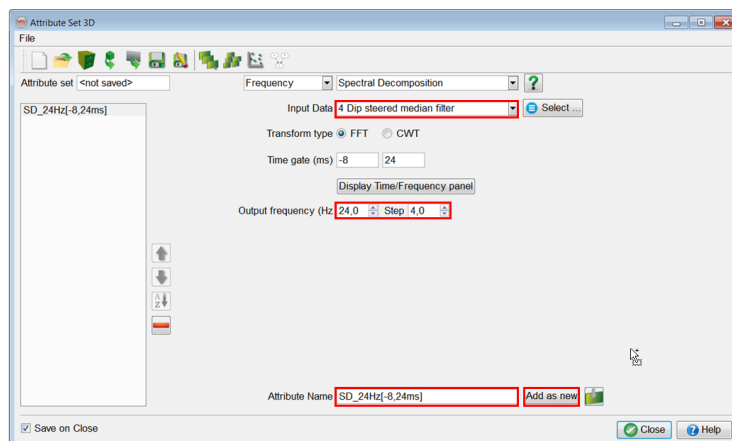

**Workflow cont'd:**

12. In the same manner, **create** the other two attributes for middle (44Hz) and high (64Hz) frequencies: **change** the output frequency value and the attribute name respectively. **Click** Add as new every time when a new attribute was defined.
13. **Click** on Close.  
Optionally, **give** a name to the new attribute set, e.g.: *Spectral Decomposition* (if Save on Close is toggled on).

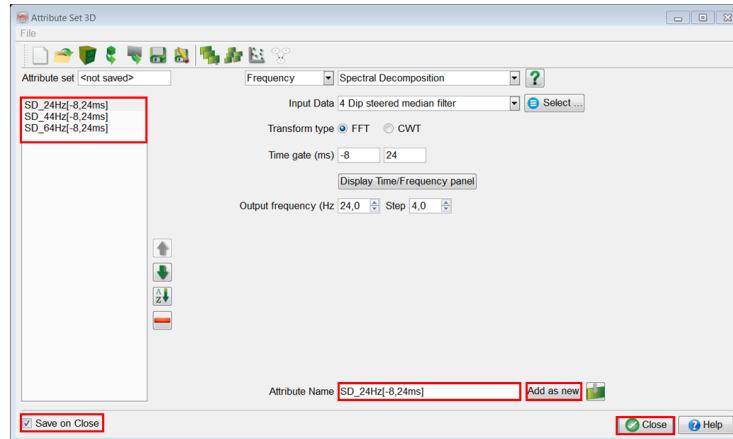

**Workflow cont'd:**

14. To convert your attributes into Horizon Data. **go** to Processing > Create Horizon Output > Attributes > 3D.

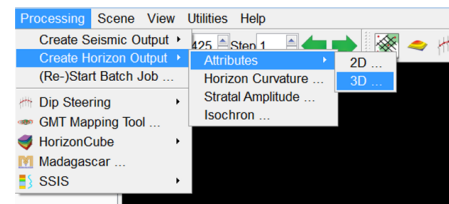

15. **Select** the *SD\_24Hz[-8,24]ms* attribute to output and the *Demo1->MSF4* horizon on which it will be output and **press** Run.
16. **Process** the two other attributes in similar way.

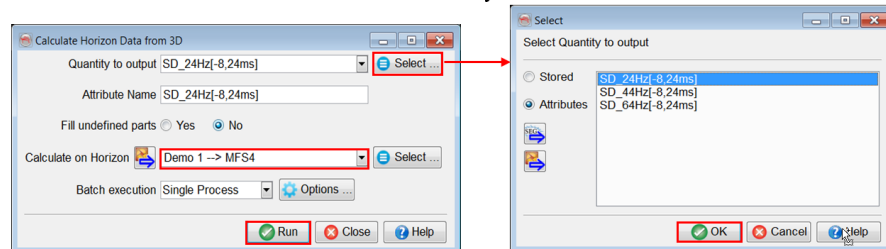

Saving as Horizon Data is faster than calculating on the fly along a horizon. Moreover, the process is done in batch, so can be preferred simultaneously for other Horizon Data.

**Workflow cont'd:**

17. **Display** the three new Horizon Data on *Demo1*-> *MFS4*: **right-click** the text adjacent to the red channel > Select attribute > Horizon Data and **select** *SD\_24Hz\_-[-8,24]ms*.

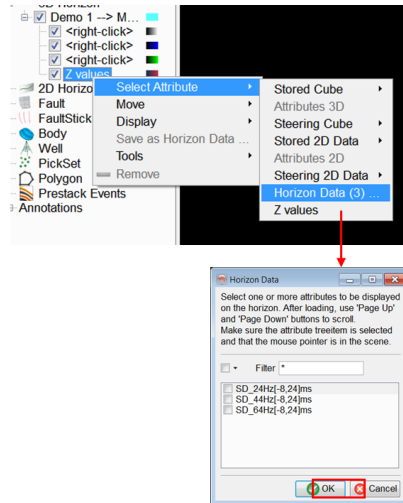

18. In the same manner, **select** *SD\_44Hz\_-[-,24]ms* data for the green channel and **select** *SD\_64Hz\_-[-8,24]ms* for the blue channel.

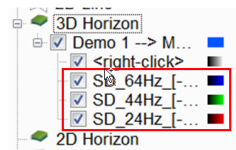

**Workflow cont'd:**

19. When blending the three inputs, the results should be similar to the one shown on the figure.

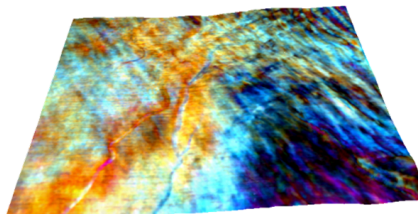

**Some extra steps:**

- Try to flip the green channel : **right-click** on the color bar, a menu pops up which allows you to flip the color bar).

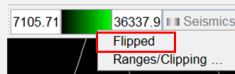

- What do you notice? Do you see one feature better than the other ones? Which paleo-geomorphological features can you interpret? What can you conclude in terms of depositional environments, water depth, litho-facies, and direction of currents?

**Workflow cont'd:**

We normally create RGB with three channels; Red, Green and Blue. A fourth attribute (called Alpha channel) can be optionally added to highlight structural features like faults/fractures.

20. To define 'Similarity' attribute and add it to the fourth layer, **open** the Attribute set 3D window with the  icon and **select** Similarity.

21. **Select** Extension: All Directions.

22. **Select** Min for Output statistics.

23. **Give** it a name (*Min\_Similarity*) and **click** Add as new.

24. **Close** the Attribute set window.

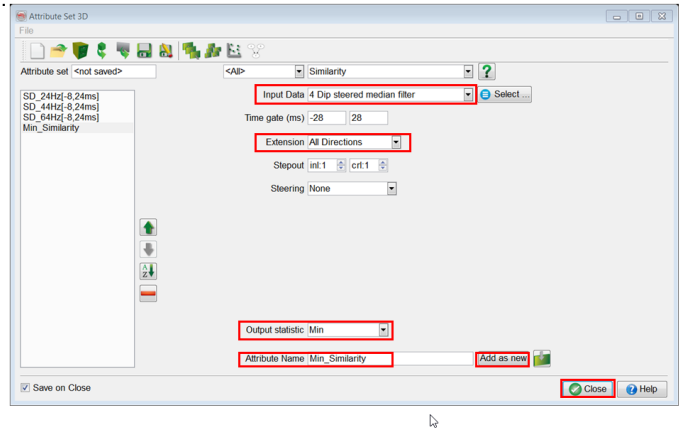

**Workflow cont'd:**

25. **Right-click** on the fourth element on *Demo1--> MFS4* > Select attribute > Attributes 3D and **select** *Min\_Similarity*.

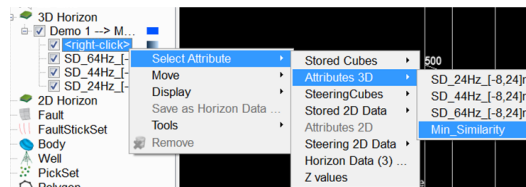

What do you notice? Do you see any structural features (faults, fractures)?

Extra Step: After processing several frequencies to a seismic volume, use PgUP and PgDN to toggle between the processed frequencies for the different channels.

## 2.3.1b Dip & Azimuth

### OpenText Pro, Dip-steering

#### Exercise objective:

Compute Dip and Azimuth attributes from a SteeringCube.

#### Workflow:

1. Go to the Attribute engine: Analysis > Attributes > 3D or click on the  icon > 3D
2. In the attribute set window, select Dip attribute.
3. Select 2 Steering BG Detailed as input and Polar dip as output.
4. Specify a name for the attribute (e.g. Polar Dip) and Add as new (optionally save it).

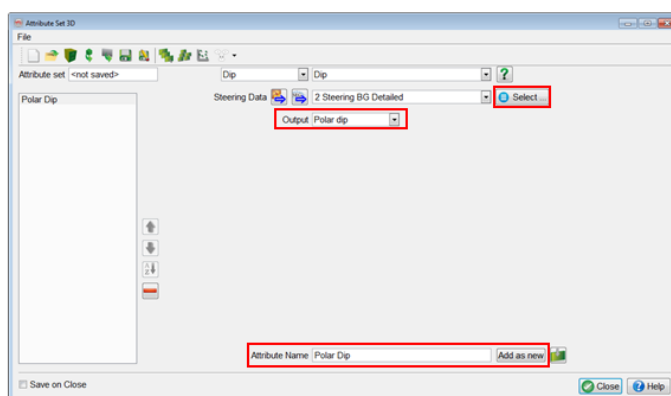
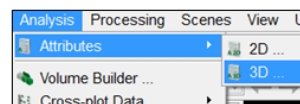

#### Workflow cont'd:

5. In the 3D scene, Load horizon Demo 1 --> MFS4 by right-clicking on 3D Horizon in the tree.

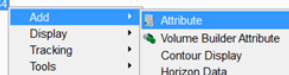
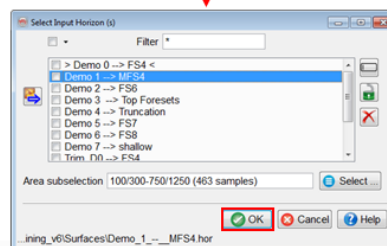
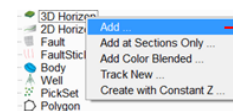

6. In the tree, right-click on the loaded horizon and follow Add > Attribute : select the Polar dip attribute. The attribute is calculated on-the-fly.

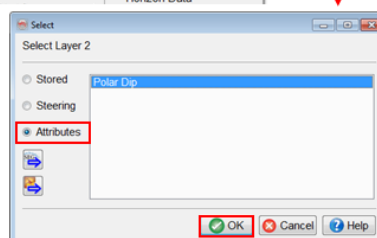

Alternatively, you could process the *PolarDip* attribute as horizon data and afterwards add it (see the section on Spectral Decomposition).

**Workflow cont'd:**

7. **Change** the colorbar to *Grey scales* and the range to 0 to 70.

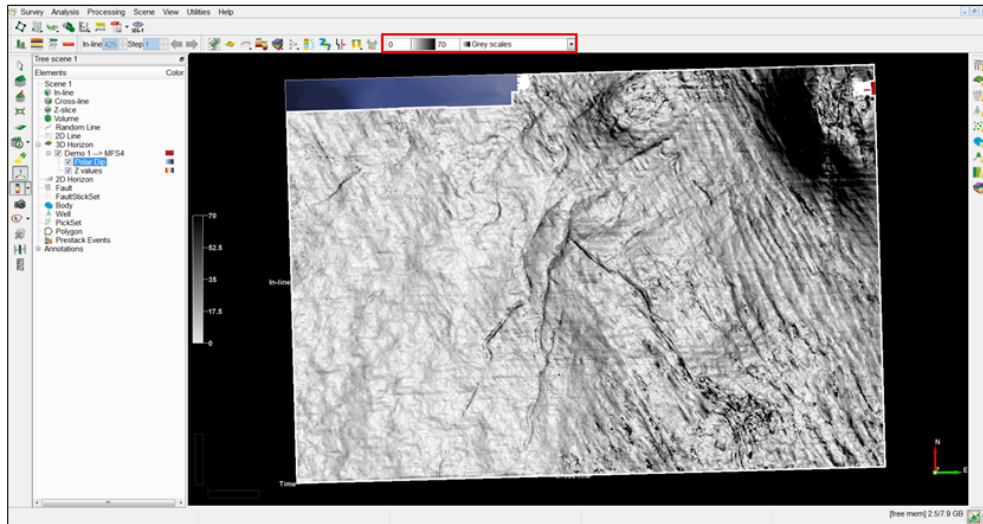

**Workflow cont'd:**

8. **Save** the attribute to the disk by **right-clicking** on it's name (i.e. *Polar Dip*), and selecting **Save as Horizon Data**.

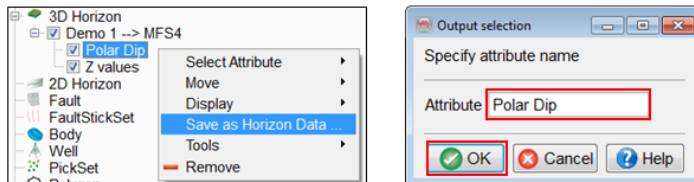

Try displaying the *Azimuth* attribute in the same way as *Polar Dip*. What differences do you see between the two?

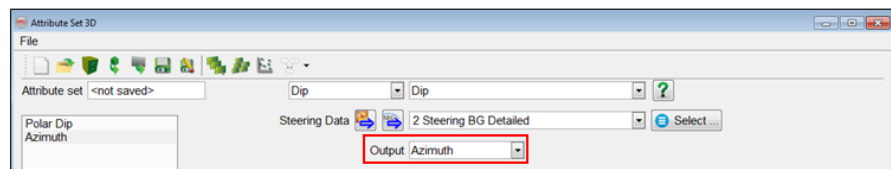

## 2.3.1c Dip-steered Similarity

Required licenses: OpendTect Pro, Dip-steering.

### Exercise objective:

Compute a Similarity attribute with and without dip-steering.

### Workflow:

1. **Go** to the Attribute engine: Analysis > Attributes > 3D or **click** on the  icon > 3D.
2. In the attribute set window, **select** Similarity attribute.
3. **Keep** the default Input Data 4 Dip steered median filter and default time gate [-28 +28] ms.

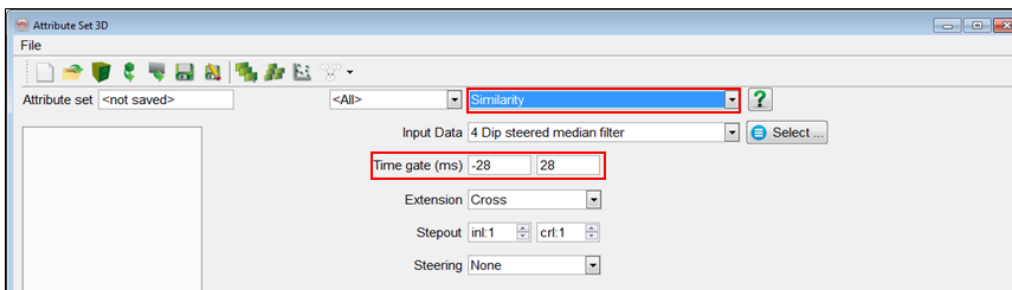
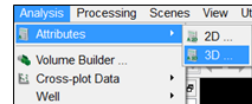

### Workflow cont'd:

4. **Select** Extension: All Directions.
5. **Keep** the default stepout, i.e. inl:1; crl:1.

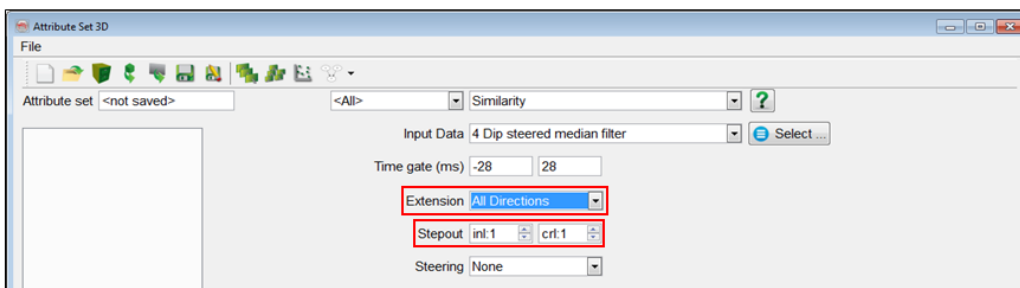



**Workflow cont'd:**

- Specify** Steering: Full and **select** 3 Steering BG Background.
- Choose** Output statistics: Min.
- Give** a name (e.g. *FS\_Similarity*) and **Add as new**.

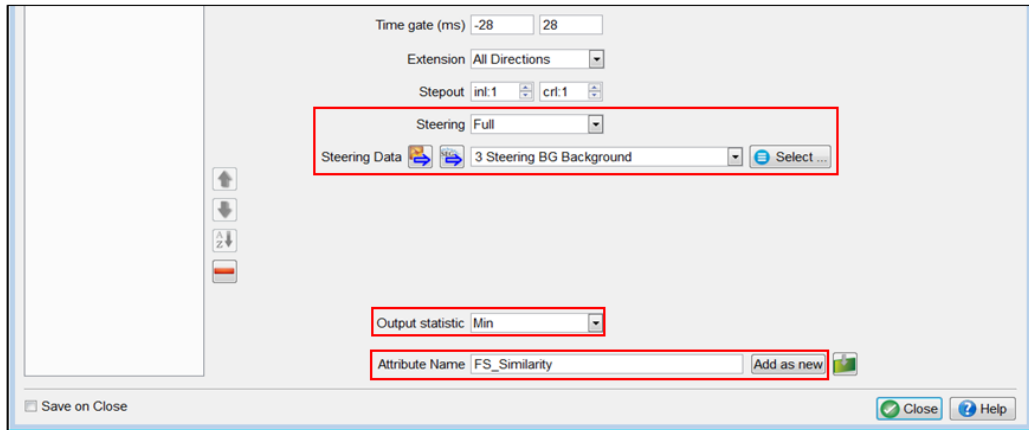

**Workflow cont'd:**

- In a similar way, define a non-steered Similarity attribute by **selecting** Steering: None.
- Give** it a name (e.g. *NS\_Similarity*) and **Add as new**. Optionally save the attribute set. **Click** on Close.

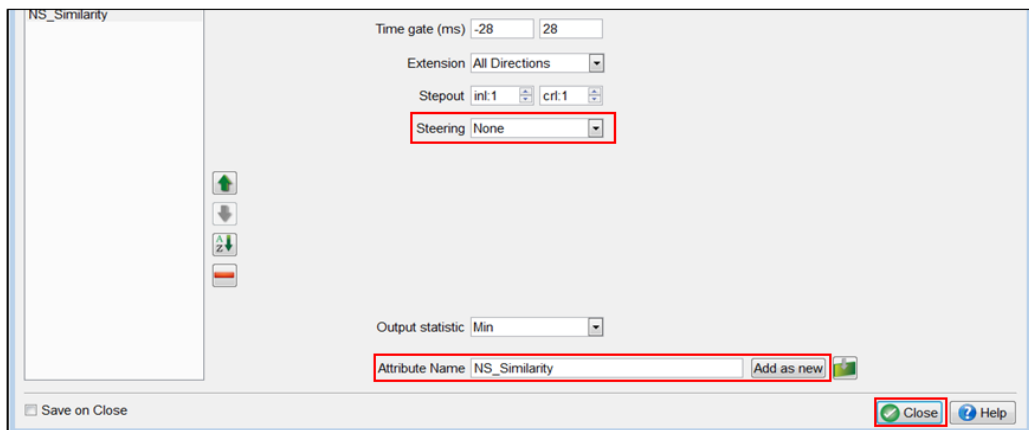

**Workflow cont'd:**

- Display** seismic data on inline 425 by **right-clicking** on In-line > Add and Select Data.  
Under the Stored tab **select 1 Original Seismics**.

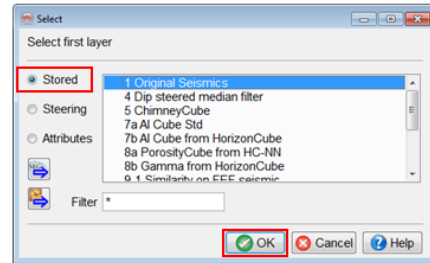
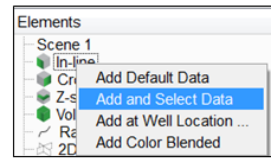

- Select** inline number 425 in the tree, **go** to the top toolbar, **change** it to 250 and **press** enter.

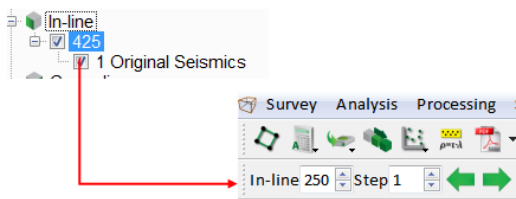

**Workflow cont'd:**

- Load** first the steered similarity attribute (i.e. *FS\_Similarity*) by **right-clicking** on inline number 250 > Add > Attribute.

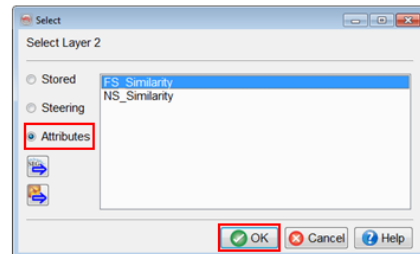
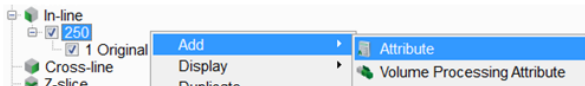

- Similarly, **load** the non-steered similarity attribute (i.e. *NS\_Similarity*).

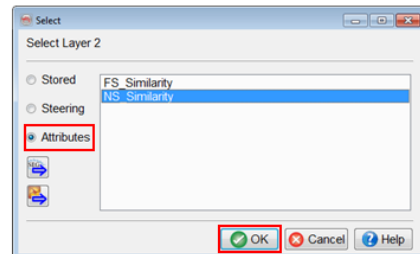
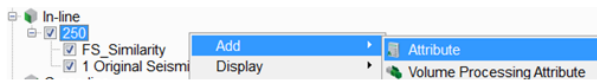

**Workflow cont'd:**

15. **Change** the color-bars of both the similarity attributes to *Similarity*.

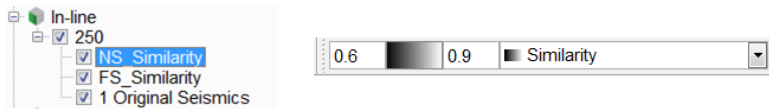

16. Compare the two similarities by **ticking on and off** the upper attribute (here NS\_Similarity).

What is the influence of dip-steering?

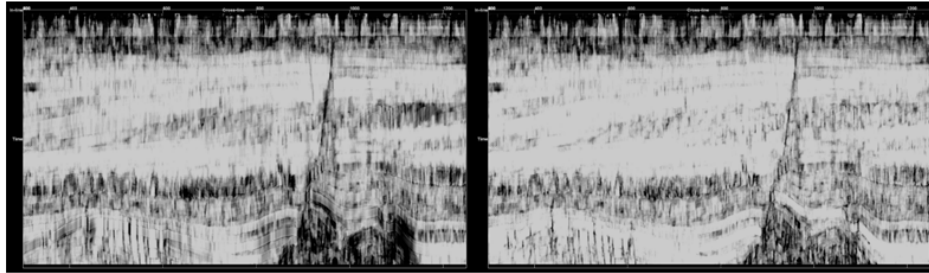

*In-line 250: Non-Steered Similarity (left) and Steered Similarity (right)*

## 2.3.1e Mathematics

Required licenses: OpendTect.

### Exercise objective:

Analyze the noise removed by the Dip-Steered Median Filter using the Mathematics attribute.

### Workflow:

Note: This exercise uses the attribute set from the previous exercise.

1. **Define** a new attribute (in addition to DSMF of previous exercise) of type Mathematics and **write** the formula: 'filtered – original' and **press** Set.

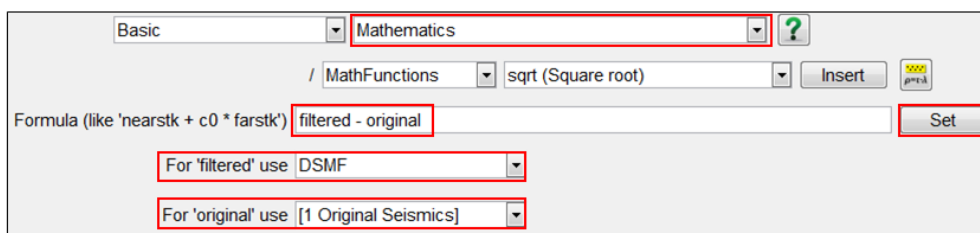

2. **Use** the previous attribute definition (i.e. *DSMF*) for filtered and the stored volume *1 Original Seismics* for original. **Give** the attribute a name (e.g. *Noise*) and **Add as new**.

### Workflow cont'd:

3. **Right-click** on inline number 425: Add > Attribute.
4. **Select** the Noise attribute.

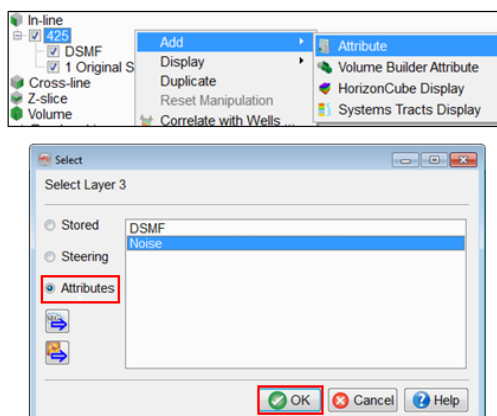

Use the same color-bar for original seismic, DSMF seismic and Noise for a fair comparison.

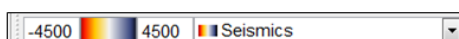

---

**Workflow cont'd:**

Your result should look like this.

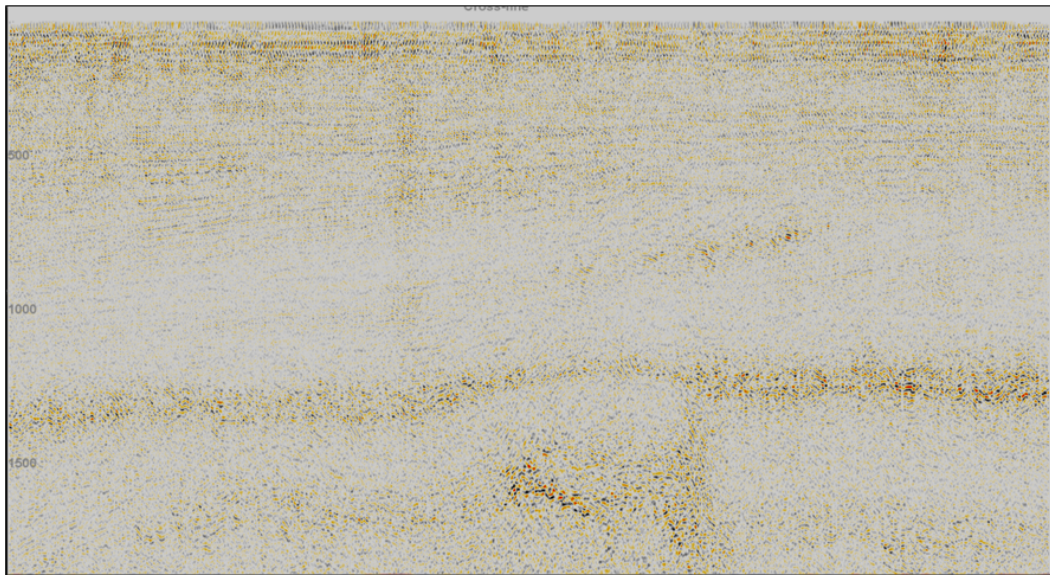

## 2.3.1h Unconformity Tracker

Required licenses: OpendTect Pro, Dip-Steering.

### Exercise objective:

Create two horizons: 1) a seismic event constrained by a few manually picked positions; 2) an unconformable event constrained by well markers.

### Workflow:

1. **Pre-load** the default seismic data set (4 Dip steered median filter).
2. **Add** an in-line (Add Default Data)
3. **Add** the stored Random Line called: "Random Line through wells"
4. **Add** all 4 wells
5. **Go** to 3D Horizon >  
New > Track Unconformity ...

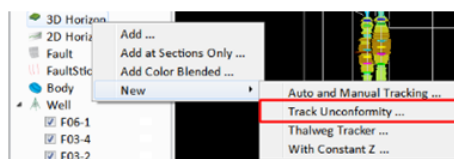

Traditional trackers follow amplitude and phase. Unconformities do not exhibit consistent amplitude / phase behavior and can thus not be tracked with a conventional tracker. The unconformity tracker flattens the dip field using a constrained inversion-based algorithm. Constraints are given in the form of picked positions and (optionally) a confidence weight volume.

### Workflow cont'd:

6. In the Unconformity tracker window, **select** the input steering cube for the tracking: 2. Steering BG Detailed.

Ideally, use a detailed steering cube (see Exercise 2.3.1a) calculated on enhanced seismic.

7. Optionally, **limit** the output extend by using the Volume sub-selection.

8. Optionally, **change** the names of Pickset and Horizon by double clicking on the respective fields.

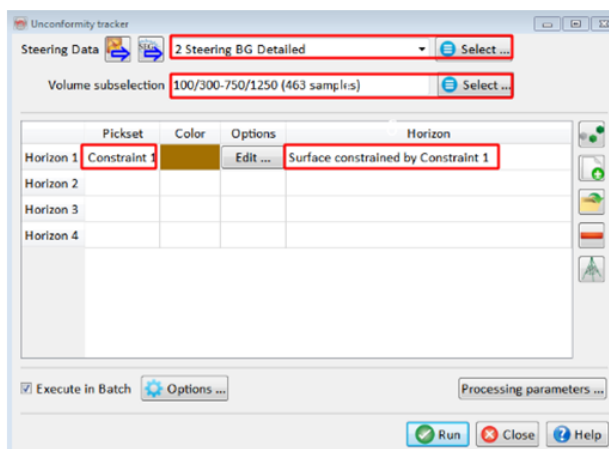

**Workflow cont'd:**

9. **Click** on the Pick Seeds icon  and pick a few points (minimum 3) on the event you want to track.

10. Optionally, **pick** more points on in-lines and cross-lines. Alternatively, open an existing pick set with interpreted points by clicking on the corresponding icon: 

11. For the second horizon **press** the wells icon  and select the FS7 marker from all wells.

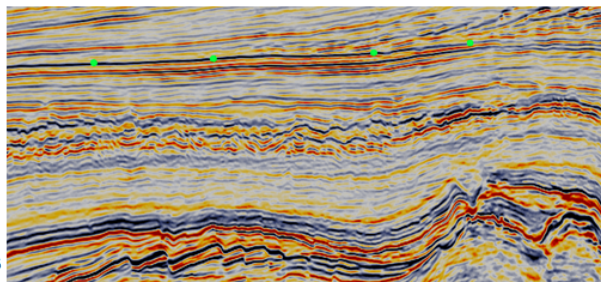

	Pickset	Color	Options	Horizon
Horizon 1	Constraint 1	Blue	Edit ...	Surface constrained by Const
Horizon 2	FS7	Green	Edit ...	Surface constrained by FS7
Horizon 3				

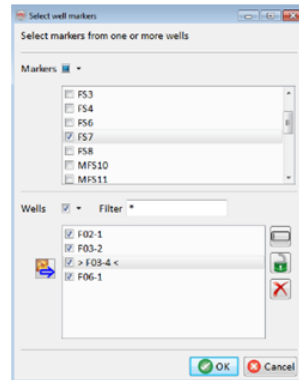

**Workflow cont'd:**

12. **Select** Processing parameters ... and read the information for each of the parameters.\*

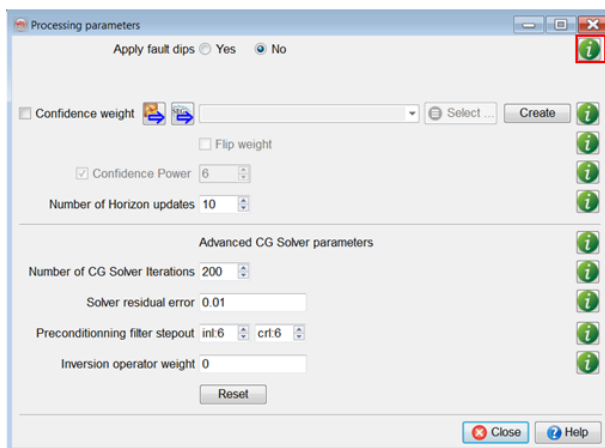

\* A good "Confidence weight" volume example is the Planarity volume.

**Workflow cont'd:**

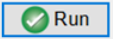
**13. Close** the Processing parameters window and start processing by pressing  Run

14. When the batch process is finished **Close** the window and **Add** the new horizons to the tree.

**15. Add** a random line to **QC\*** the horizons.

16. Improvements can be made by (if needed): adding more picks; adding a confidence weight volume and by changing the inversion parameters.

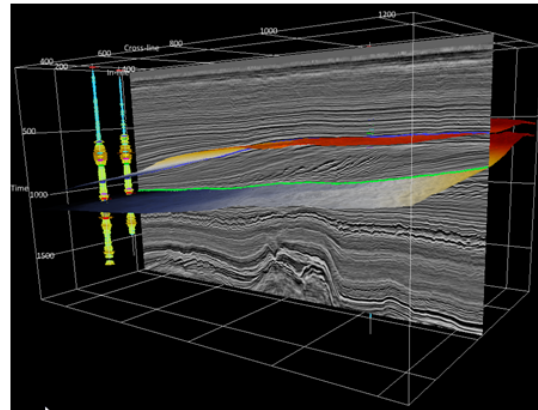

\*Tips: Change the color bar of the random line to grey scale; Show the horizons at sections only; Change the line thickness (Horizon -> Display -> Properties); Move and rotate the random line to check whether the horizon is following the events properly.



## 2.3.2a Thinned Fault Likelihood

Required licenses: OpendTect Pro, Faults & Fractures.

### Exercise objective:

Create Thinned Fault Likelihood attribute.

### Workflow:

1. **Launch** the Faults and Fractures Control Center by clicking this  icon.
2. **Select** 3D
3. **Select** the Thinned Fault Likelihood attribute from the list and **press** Go...

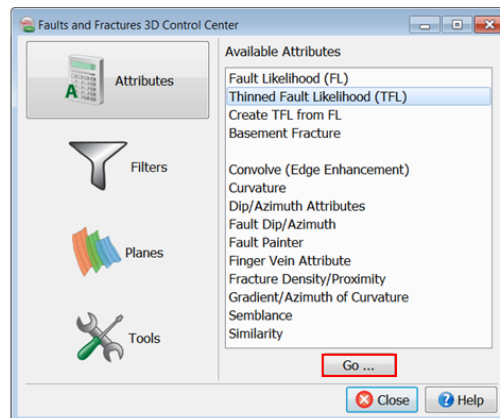
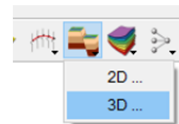

### Workflow cont'd:

3. **Specify** the Input Cube *4 Dip steered median filter*.
4. To speed up the process **set** Volume sub-selection to inline 120-400, crossline 350-600, z range 1400-1848.
5. **Choose** *Advanced Settings* to view the parameters.
6. **Keep** the default parameters, as shown in the image on the right and Close the advanced parameters dialog.
7. **Provide** an Output Cube name, e.g. Thinned Fault Likelihood, and **press** Run.

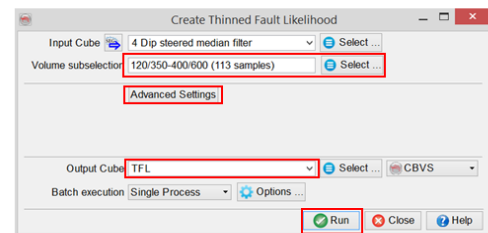

Keep a large Z stepout (recommended)

Smoothing along dip/strike increases the continuity of a fault plane. Over smoothing may also enhance outliers.

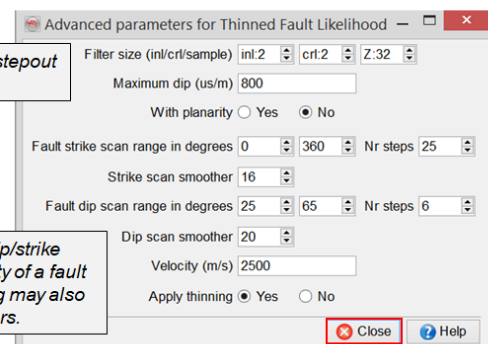

---

**Workflow cont'd:**

8. When processing is finished, **display** the Thinned Fault Likelihood on inline 200.
  - **Right-click** on inline > Add Default Data.
  - **Change** the inline number to 200.
  - **Right-click** on inline nr. (i.e. 200) > Add Attribute; Under the Stored section, **select** Thinned Fault Likelihood.
9. **Apply** semi-transparent color bar (e.g. Chimney) on it for better visualization.
10. The result should be similar to the one shown below.

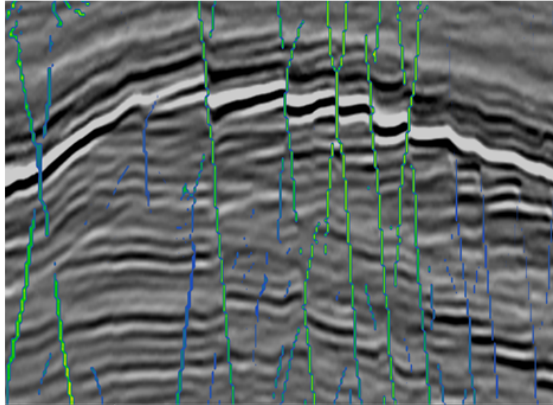

## 2.3.2b Volume Curvature And Others

Required licenses: OpendTect Pro, Dip-steering.

### Exercise objective:

Compute and compare various attributes that pick up faults and fractures.

### Workflow:

1. **Start** the 3D attribute engine: **Analysis > Attributes > 3D**.

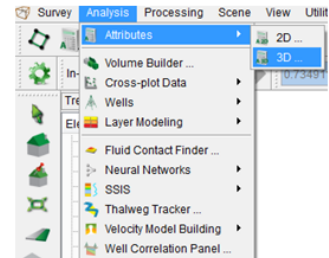

### Workflow cont'd:

2. **Select** Similarity attribute from the list of attributes.
3. Keep all the parameters by default and give it a name, e.g. *Non\_steered\_Similarity*.
4. **Press** Add as new.

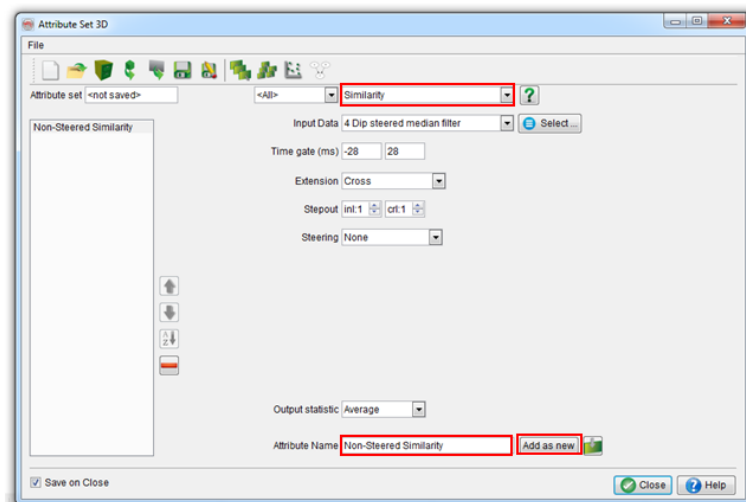

**Workflow cont'd:**

5. **Change** Steering to Full with 3 Steering BG Background.
6. **Type in a new name:** *Steered Similarity*.
7. **Press** Add as new.

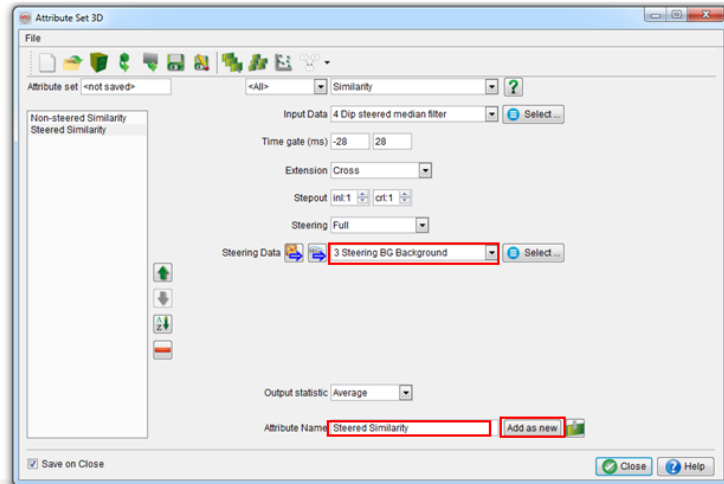

**Workflow cont'd:**

8. **Select** Curvature from the list of attributes.
9. **Change** output to Most pos curvature and **type in a new name**, e.g. *Most Positive Curvature*.
10. **Press** Add as new.

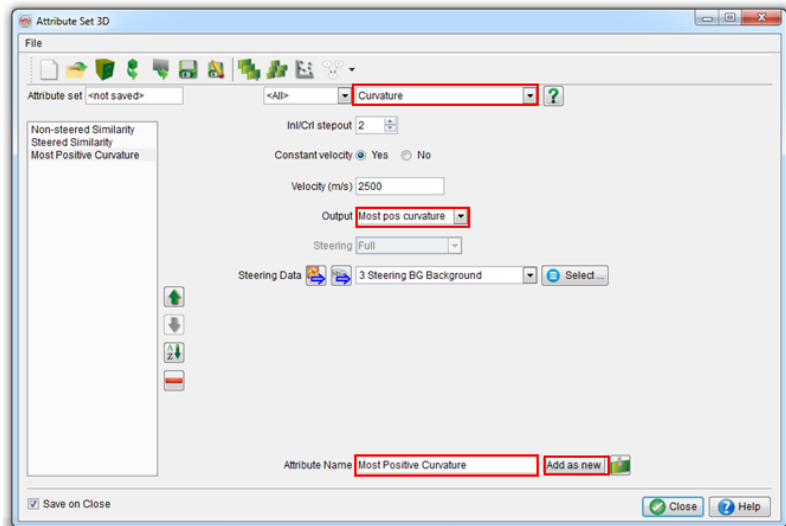

**Workflow cont'd:**

- 11. Change** Output to Most neg curvature and **type in a new name**, e.g. *Most Negative Curvature*.
- 12. Press** Add as new.

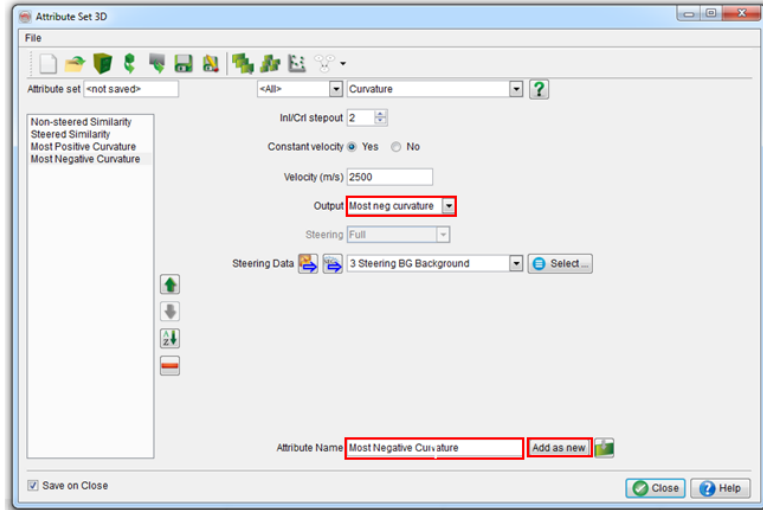

**Workflow cont'd:**

- 13. Select** Dip from the list of attributes.
- 14. Change** Output to Polar dip and **type in a new name**, e.g. *Polar Dip*.
- 15. Press** Add as new, **Un check** Save on close and **Close** the window.

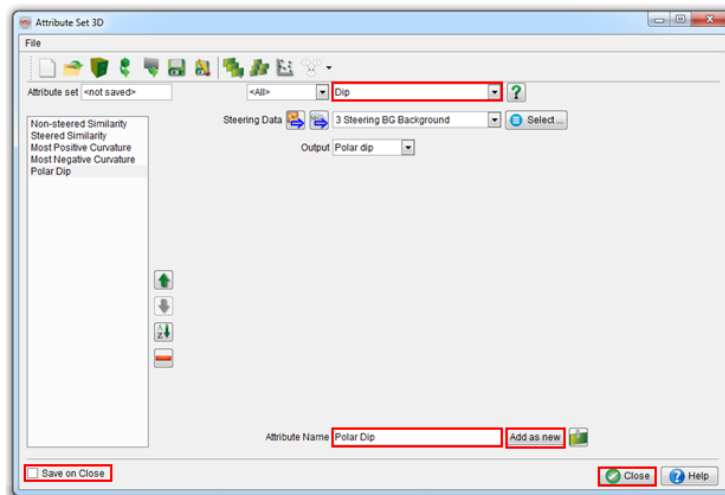

**Workflow cont'd:**

16. **Right-click** on Z-slice in the tree > **Add and Select Data**.

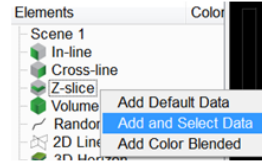

17. As visualization of the full z-slice will take some time, we will limit the inline and crossline ranges. So, **press Cancel** in the pop-up window.

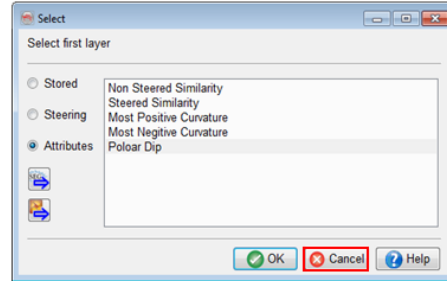

18. **Right-click** on the Z-slice number in the tree > **Display > Position**.

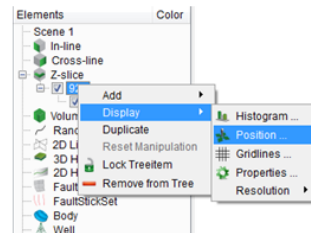

**Workflow cont'd:**

19. **Position** Z slice 1640ms between inlines 120-400 and crosslines 350-600 and **press OK**.

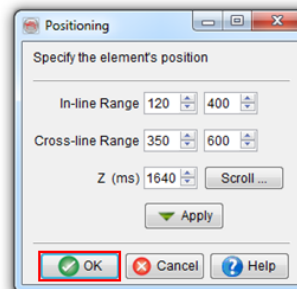

20. In the pop-up window **select Non-steered Similarity** from Attributes tab.

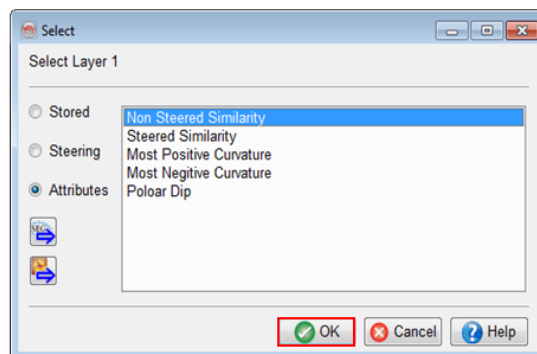

21. **Press OK** to display it in the scene.

**Workflow cont'd:**

22. **Right-click** on the Z-slice 1640 in the tree > Add > Attribute.

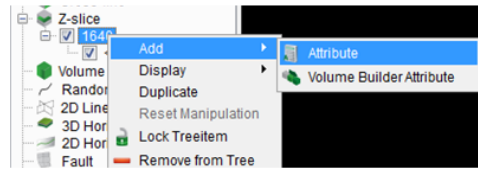

23. In the pop-up window **select** *Steered Similarity* from Attributes tab.

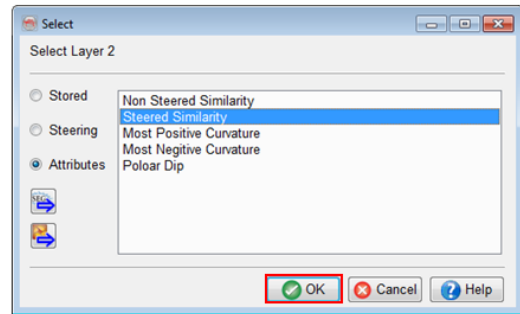

24. **Press OK** to display it in the scene.

25. In similar way **display** the rest three attributes.

**Workflow cont'd:**

26. Now you can compare them by checking/unchecking the attributes.

27. **Click** on an attribute in the tree to make it active and change the color bar to *Similarity*. Do the same for all the attributes.

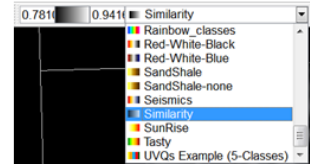

28. The result should be similar to the one shown below. Display and compare the different attributes. What do they highlight, and why? Which attributes are best under what circumstances, and for which purpose (fault or fractures)?

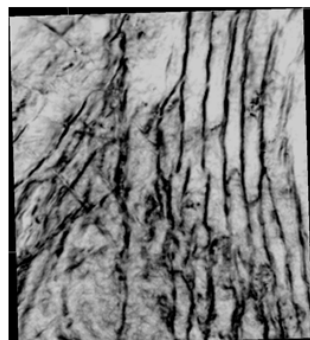

Steered Similarity

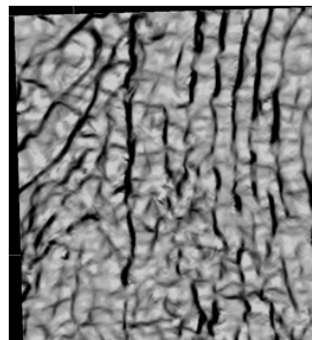

Most Negative Curvature

## 2.4.2g Stratigraphic Attributes

Required licenses: OpendTect Pro, HorizonCube.

### Exercise objective:

Define and understand the HorizonCube/SSIS attributes.

### Workflow:

1. Launch the **3D attribute** set window. 
2. **Select** a HorizonCube density attribute.

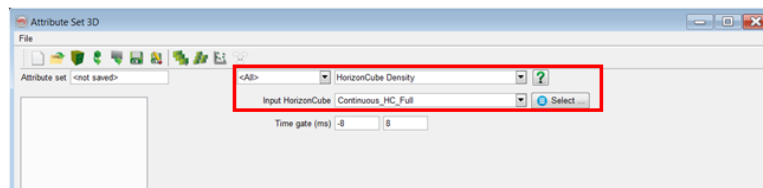

We suggest using a Continuous HorizonCube as an input for this attribute because it requires horizons within a specified time gate. The truncated HorizonCube removes such events and hence this attribute is not suitable for such inputs.

### Workflow cont'd:

3. **Specify** the attribute name and **add it as new**.

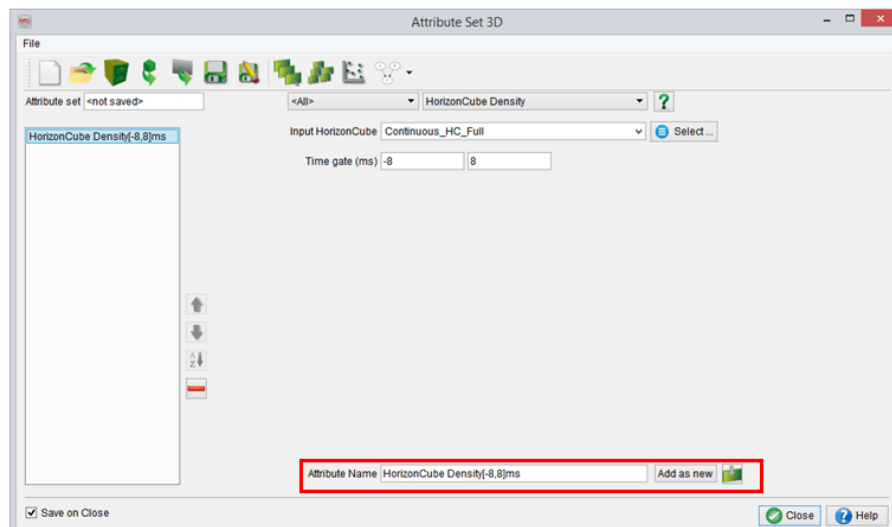



### Workflow cont'd:

- Following the previous steps (2-3), **define\*** a few more attributes e.g. HorizonCube layers and Systems tract (Common ID, Unique ID, and Isochron) attributes.

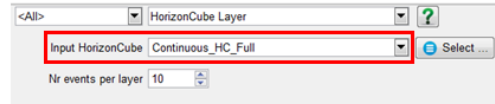

Note the input HorizonCube for this attribute is the truncated one because the interpretation is made on that input.

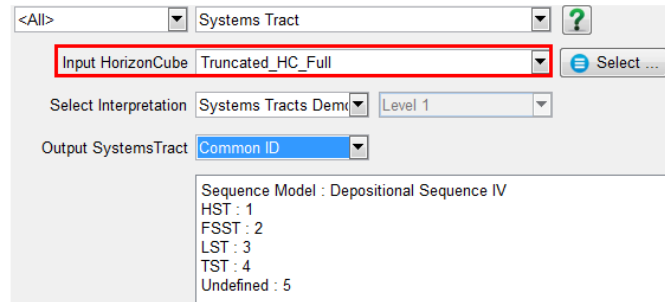

\* Per defined attribute, you will have to specify its name and press the button add as new.

### Workflow cont'd:

- Once you have defined these five attributes, **save**  the attribute set as e.g. *Stratigraphic Attributes*. If the name already exists, then overwrite.
- Close** the attribute set window.

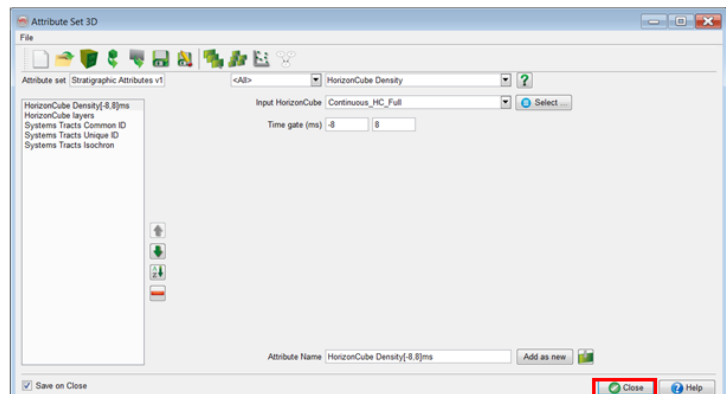
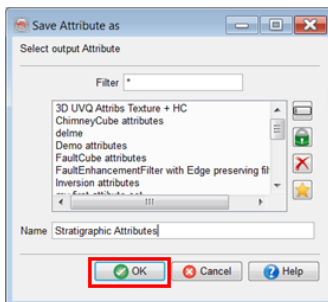

**Workflow cont'd:**

7. Next you may want to **display these attribute** on an inline before processing.

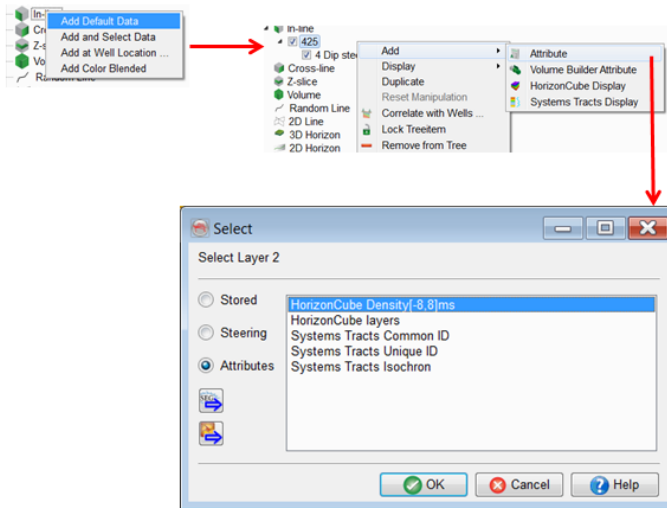

**Workflow cont'd:**

8. Following the same steps, **overlay the remaining** attributes on the same inline.

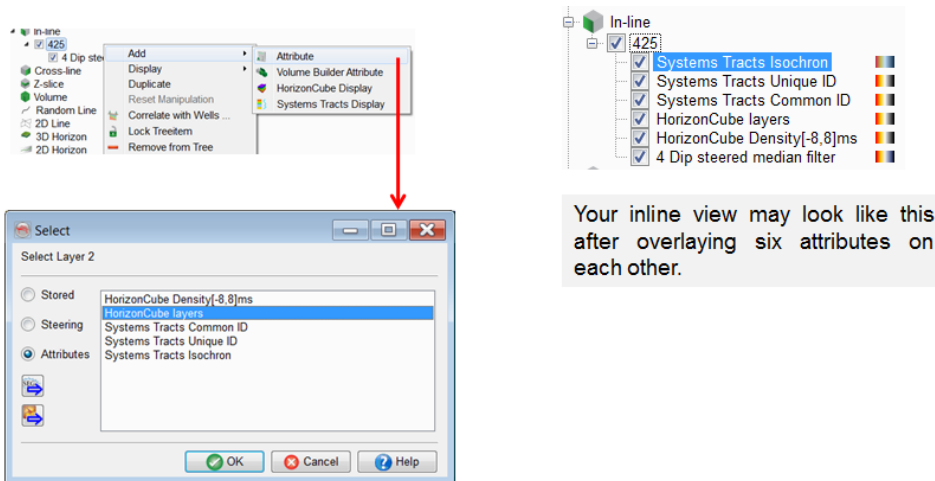

## Workflow cont'd:

- Your attributes may have a **green/yellow** coloured (default undefined values) areas which could be set to transparent by following these steps.

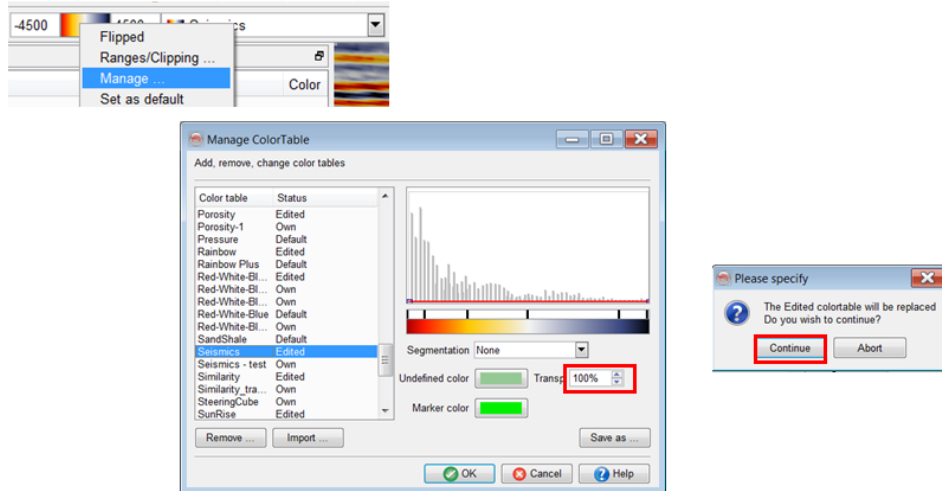

## Your results may look like this:

### HorizonCube Density:

Black regions in this case represent gaps in deposition e.g. unconformities and condensed sections.

### HorizonCube Layers:

This is like an input model containing layer definition per 10th event. A good input for geological/reservoir modeling.

### Systems Tracts Common ID:

A repetition of same colour in this case represents the same systems tract, which has a common ID in this volume. Again, this volume can be used for modelling or prediction purposes.

### Systems Tracts Unique ID:

All systems tracts have their own unique IDs in this volume.

### Systems Tracts Isochron:

This is a thickness volume per systems tract. A good product to explain the base-level variations based on your data. Or adding another dimension to the Wheeler diagrams when this attribute is used as an overlay in the Wheeler scenes (e.g. 4D Wheeler diagrams).

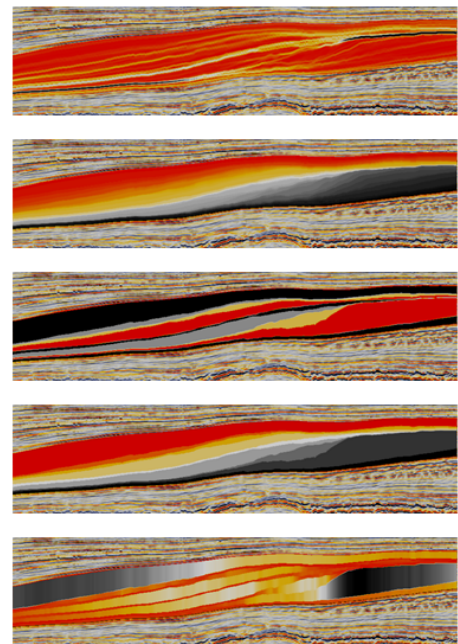

## 1.5.3a Attributes - Attributes

Required licenses: OpendTect.

### Exercise objective:

Analyze the attribute response of the bright-spot amplitude anomaly by cross-plotting the iso-frequency attributes

### Workflow:

1. **Right-click** on 3D Horizon in the tree and **click** on Add color blended...  
**Choose** horizon *Demo-6* -> *FS8* from the list of horizons.

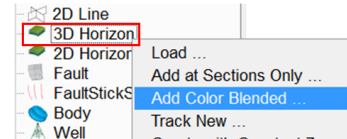

2. **Launch** the Attribute Set 3D window: **click** on the  icon.
3. **Choose** Spectral Decomposition from the list of attributes.

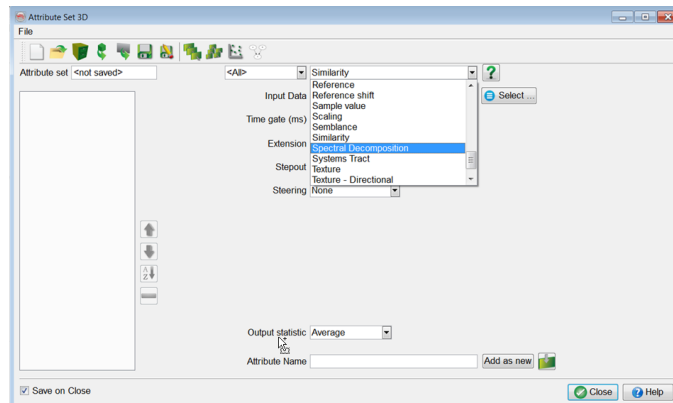

### Workflow cont'd:

4. **Change** the time gate to [-12,12]ms.
5. **Change** output frequency to 24Hz with a step of 4Hz.
6. **Give** it a name, e.g. *FFT [-12,12]ms 24Hz*, and **press** Add as new.

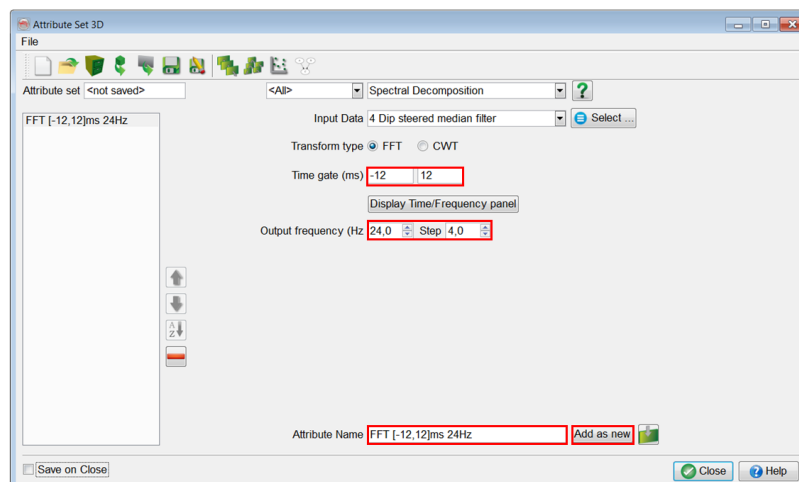

**Workflow cont'd:**

7. In similar way **define** two more Spectral Decomposition attributes of 44Hz and 64Hz.
8. **Give** them appropriate names, e.g. *FFT [-12,12]ms 44Hz* and *FFT [-12,12]ms 64Hz*, each time **pressing** Add as new.
9. **Uncheck** Save on Close and **press** Close.

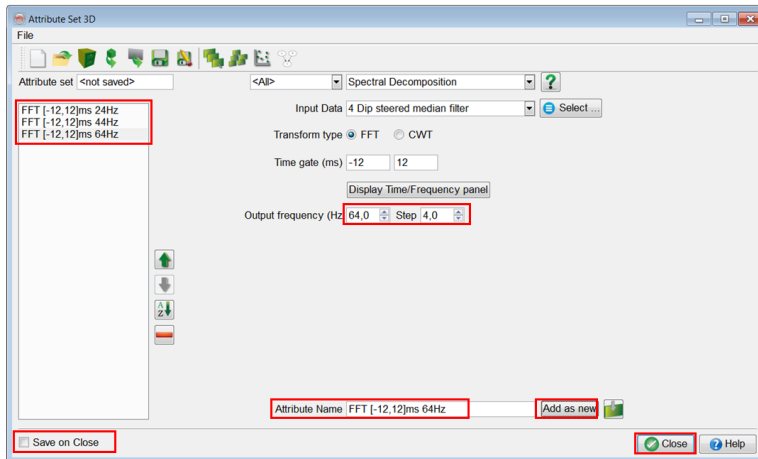

Optionally save the attribute set. In this case "Save on close" should be checked.

**Workflow cont'd:**

10. Apply these three attributes on the horizon (red-24Hz, green-44Hz, and blue-64Hz): **right-click** on the red channel and **go** Select attribute > Attributes 3D > *FFT [-12,12]ms 24Hz*.

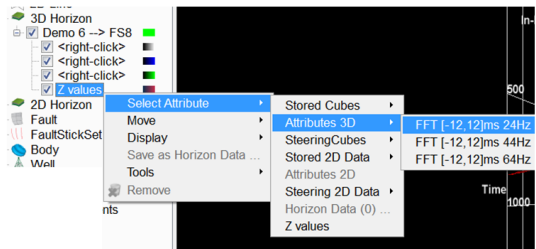

11. In the same manner **select** for the green (44Hz) and blue (64Hz) channels.
12. **Click** on the View icon  and **select** View North Z to observe the result.

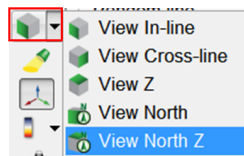

**Workflow cont'd:**

13. **Right-click** on the Polygon in the tree > New.

14. **Type in** the name *Shallow bright spot* and **Press** OK.

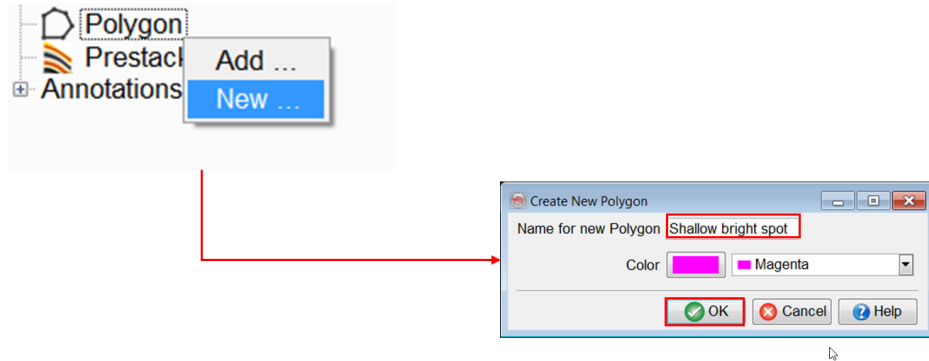

**Workflow cont'd:**

15. **Use** left mouse button to outline a polygon.

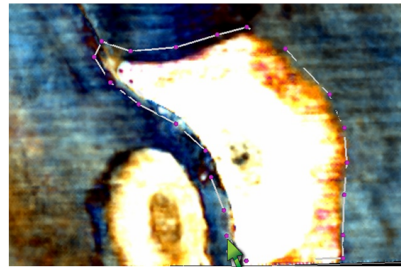

16. When finished, **right-click** on this newly added polygon in the Tree and **select** Close Polygon.

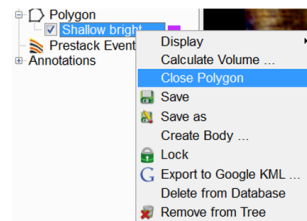

17. **Right-click** again on the polygon name and **Save**.

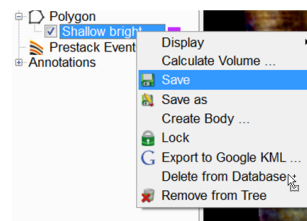

**Workflow cont'd:**

- 18. **Go** to the menu Analysis > Cross-plot Data > Attributes Vs Attributes... or **click on** the cross-plot icon.

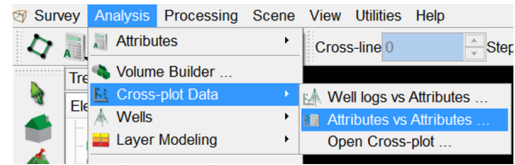

- 19. **Select** the three attributes just created.

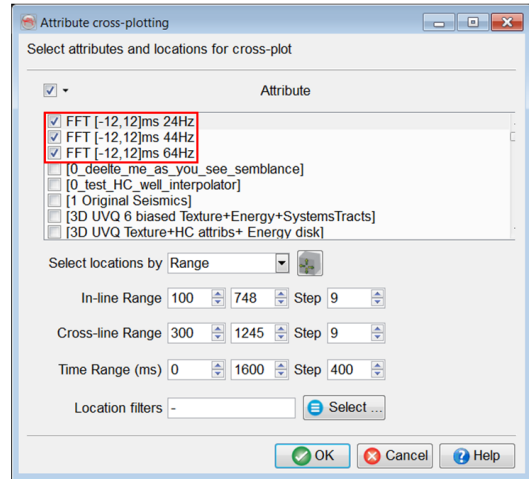

**Workflow cont'd:**

- 20. **Select** location by – Polygon.
- 21. **Select** *Shallow Bright Spot* polygon.
- 22. **Change** Inline & Cross line steps to 1 and time step to 4ms.
- 23. **Click** Select for Location filter.

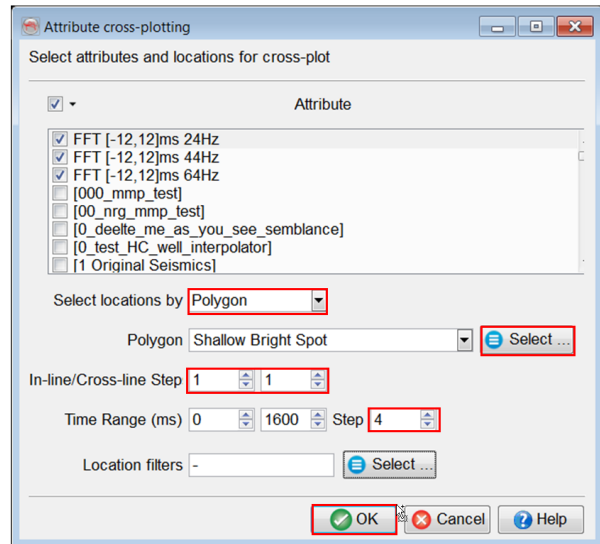

**Workflow cont'd:**

- 24. **Check** the Horizon option.
- 25. **Select** the horizon *Demo6 -> FS8*.
- 26. **Click** OK in both windows to proceed.

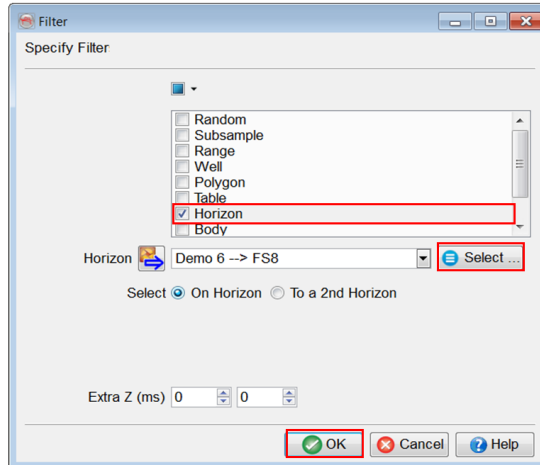

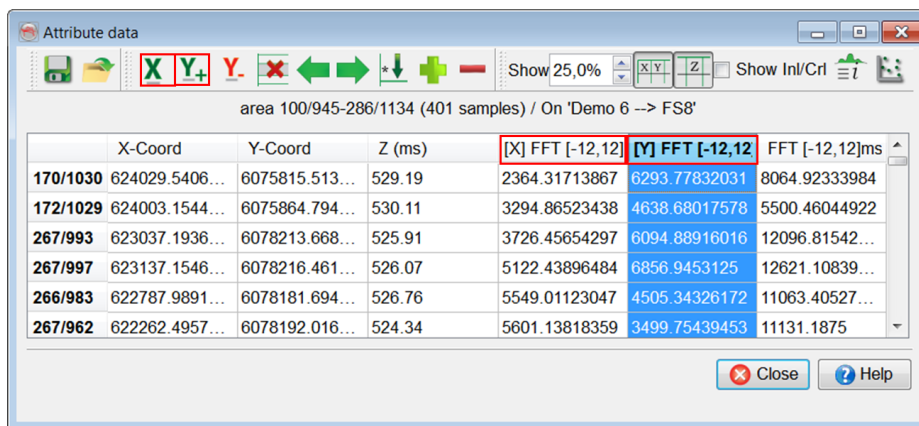

**Workflow cont'd:**

- 27. In the pop-up spreadsheet, **select** *FFT [-12,12]ms 24Hz* to be displayed along X-axis: **click** on *FFT [-12,12]ms 24Hz* column and then **click** on **X** icon.
- 28. **Assign** *FFT [-12,12]ms 44Hz* to Y-axis: **click** on *FFT [-12,12]ms 44Hz* column and then **click** on **Y+** icon.





**Workflow cont'd:**

29. Optionally add more attributes to the Y-axis by selecting a column and pressing **Y<sub>+</sub>** icon. Or remove the selection by pressing Unselect icon. **Y<sub>-</sub>**
30. **Click** on the Save icon  to save the crossplot data and **provide** a name and **click** OK.
31. **Press** Cross-plot icon  to plot the selected data.

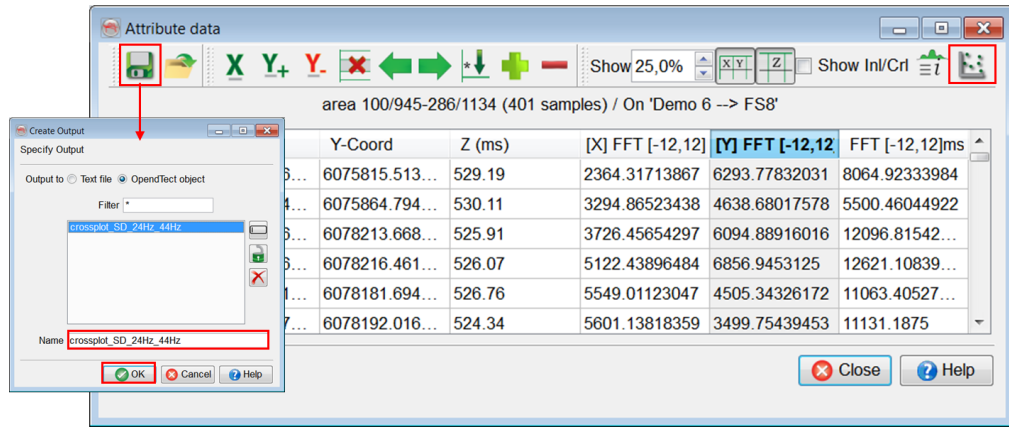

The screenshot shows the 'Attribute data' window with a table of data. A 'Create Output' dialog box is open, showing the name 'crossplot\_SD\_24Hz\_44Hz' and 'OK' button highlighted.



	Y-Coord	Z (ms)	[X] FFT [-12,12]	[Y] FFT [-12,12]	FFT [-12,12]ms
3...	6075815.513...	529.19	2364.31713867	6293.77832031	8064.92333984
4...	6075864.794...	530.11	3294.86523438	4638.68017578	5500.46044922
5...	6078213.668...	525.91	3726.45654297	6094.88916016	12096.81542...
6...	6078216.461...	526.07	5122.43896484	6856.9453125	12621.10839...
1...	6078181.694...	526.76	5549.01123047	4505.34326172	11063.40527...
7...	6078192.016...	524.34	5601.13818359	3499.75439453	11131.1875

**Workflow cont'd:**

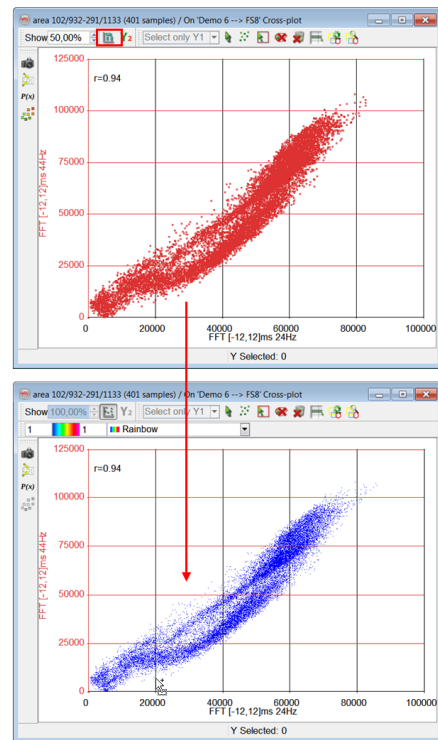
32. To have a better feel of the data's behavior **toggle** the density plot  button in the scattered cross-plot window.



**Workflow cont'd:**

- 33. **Click** on  icon to reverse the selection tool.
- 34. Using the selection tool  **draw** a free-hand polygon, as shown in green color on the figure.
- 35. **Click** Show points in 3D scene  button

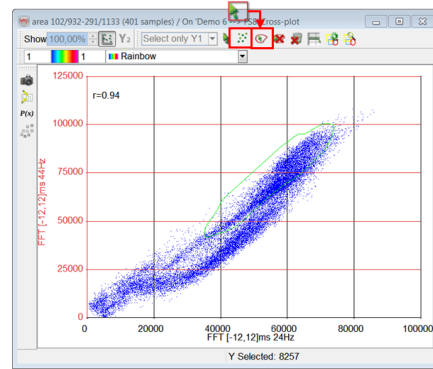

- 36. In the pop-up window **choose** an option Selected Points to display the selected scattered data and **Press OK**.

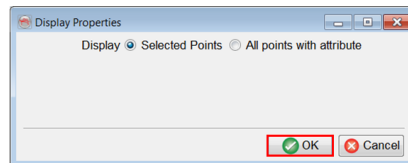

**Workflow cont'd:**

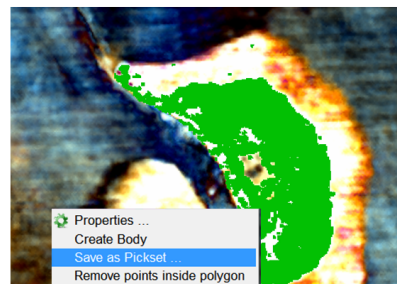

- 37. In the scene, **right-click** on the green colored displayed picks > Save as Pickset...

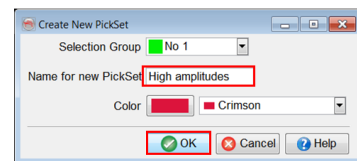

- 38. **Give it a name**, e.g. *High amplitudes*, and **press OK**.



**Workflow cont'd:**

- 39. In the Cross-plot window **click** on  icon to remove the previous selection.
- 40. **Draw** a new polygon as shown on the figure.
- 41. **Click** Show points in 3D scene  button

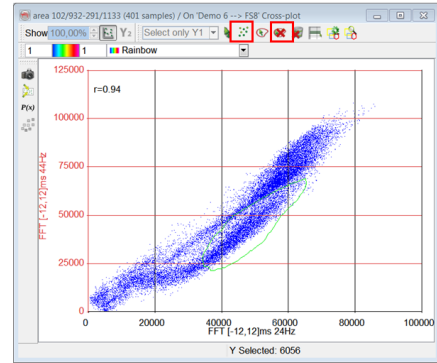

- 42. **Choose** an option Selected Points to display the selected scattered data > **Press** OK.

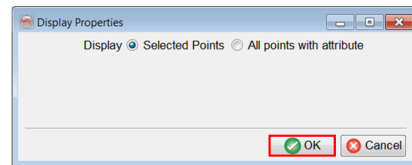

**Workflow cont'd:**

- 43. In the scene, **right-click** on the green colored displayed picks > Save as Pickset...

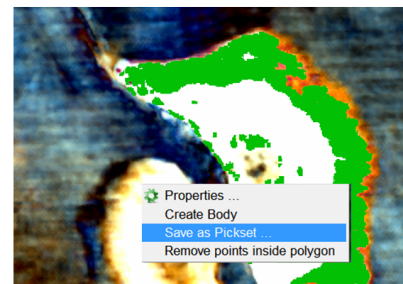

- 44. **Give it a name**, e.g. Low amplitudes and **press** OK.

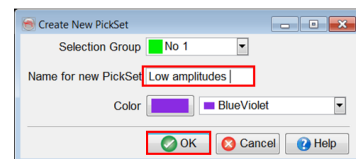

---

**Workflow cont'd:**

**Some extra steps:**

- The scattered data selected in the previous figure can be displayed as pick sets. Note that the separation of frequency highlights two different regions of the bright spot.
- The cross-plot has helped to identify the changes in the gas pocket that are possibly due to differences in saturation/thicknesses. Optionally, you can repeat the exercise to cross-plot all three attributes together FFT 24Hz, 44Hz and 64Hz.

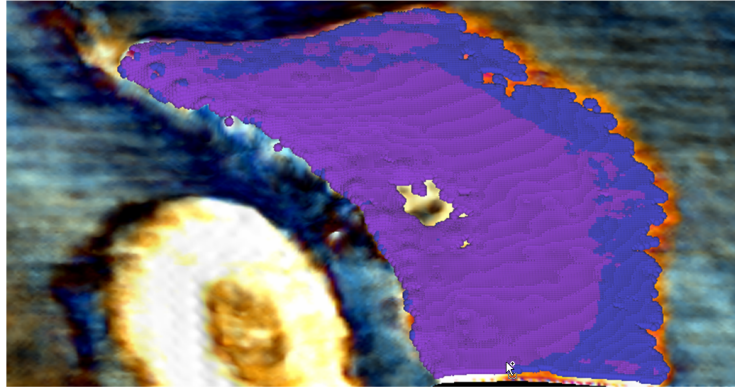

## 1.5.3b Attributes - Wells

Required licenses: OpendTect.

### Exercise objective:

Analyze relationships between seismic attributes and well logs using cross-plots.

### Workflow:

1. **Launch** the Attribute Set window  > 3D or **follow** Analysis > Attributes > 3D.
2. **Define** Instantaneous Amplitude attribute: **Select** Instantaneous from the list of attributes and keep all the default parameters for this exercise.
3. **Type in a name**, e.g. *Inst\_Amplitude*, and **Add as new**, so that the attribute appears in the list of defined attributes on the left-hand side.

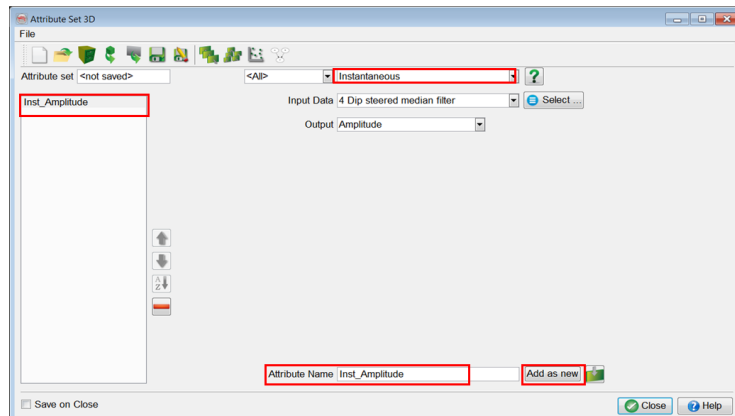

### Workflow cont'd:

4. In similar way **define** two more attributes: Energy and Dominant Frequency (Listed under "Frequency" option in the attribute list), using all the default parameters.
5. **Close** the window.

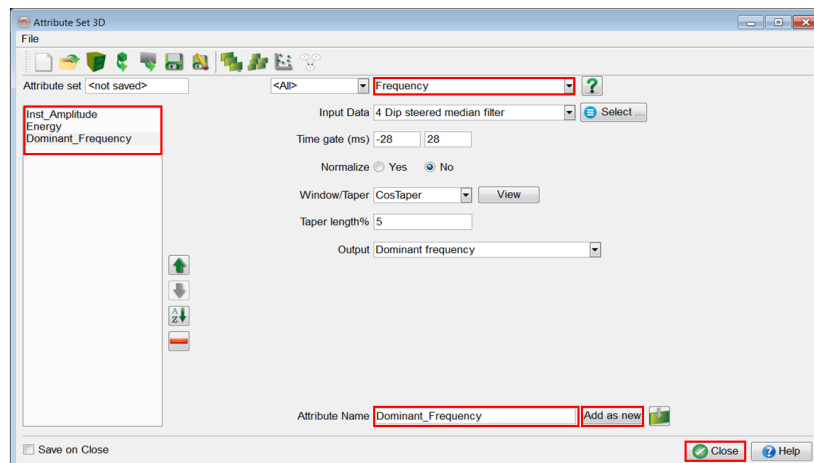

If the Save on Close box is ticked, the attribute set will be automatically stored when closing. When closing an unsaved attribute set, you will have the option to store it.

**Workflow cont'd:**

6. **Go to** the menu Analysis > Cross-plot Data > Well logs Vs Attributes... or **click** on the cross-plot  icon.

7. **Select** the three defined attributes in the Attribute section.

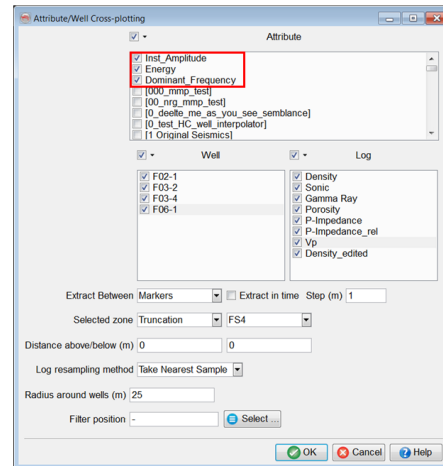
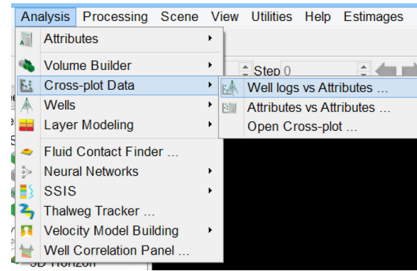

**Workflow cont'd:**

8. **Select** all available wells and logs.

Use Ctrl+A shortcut to select all items from the list or tick the box on top of the item list.

9. **Extract** between the Truncation and FS4 markers.

10. **Press** OK button to proceed.

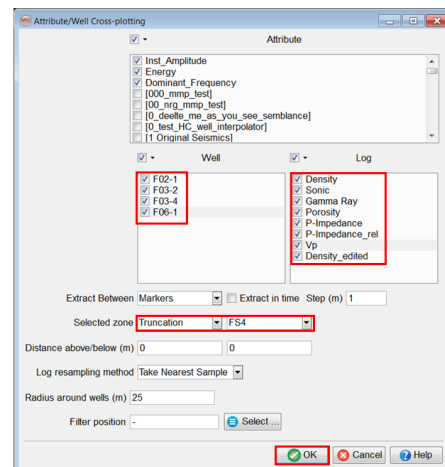

**Workflow cont'd:**

11. In the pop-up spreadsheet, **select** GR log to be displayed along X-axis: **click** on GR log column and then on **X** button.
12. **Assign** Dominant frequency attribute to Y-axis: **click** on Dominant Frequency column and then on **Y+** icon.
13. **Press** Cross-plot button  to plot the selected data.

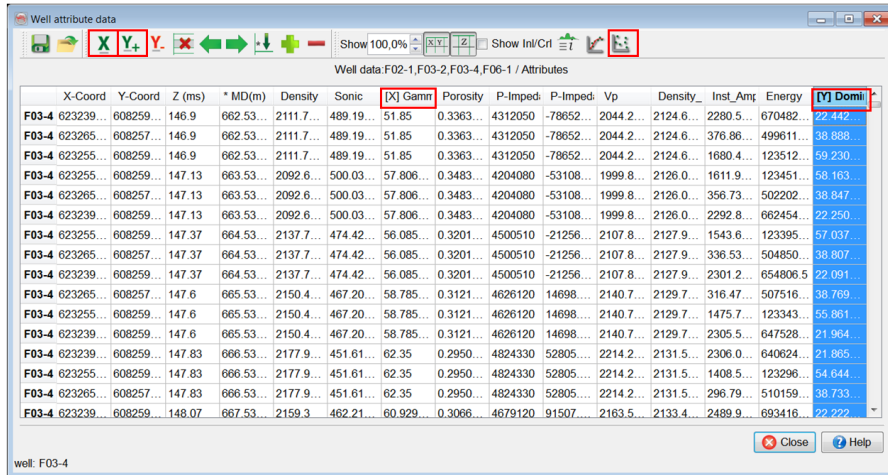



	X-Coord	Y-Coord	Z (ms)	* MD(m)	Density	Sonic	[X] Gamma	Porosity	P-Imped	P-Imped	Vp	Density	Inst_Amr	Energy	[Y] Domini
F03-4	623239...	608259...	146.9	662.53...	2111.7...	489.19...	51.85	0.3363...	4312050	-78652...	2044.2...	2124.6...	2280.5...	670482...	22.442...
F03-4	623265...	608257...	146.9	662.53...	2111.7...	489.19...	51.85	0.3363...	4312050	-78652...	2044.2...	2124.6...	376.86...	499611...	38.888...
F03-4	623255...	608259...	146.9	662.53...	2111.7...	489.19...	51.85	0.3363...	4312050	-78652...	2044.2...	2124.6...	1680.4...	123512...	59.230...
F03-4	623255...	608259...	147.13	663.53...	2092.6...	500.03...	57.806...	0.3483...	4204080	-53108...	1999.8...	2126.0...	1611.9...	123451...	58.163...
F03-4	623265...	608257...	147.13	663.53...	2092.6...	500.03...	57.806...	0.3483...	4204080	-53108...	1999.8...	2126.0...	356.73...	502202...	38.847...
F03-4	623239...	608259...	147.13	663.53...	2092.6...	500.03...	57.806...	0.3483...	4204080	-53108...	1999.8...	2126.0...	2292.8...	662454...	22.250...
F03-4	623255...	608259...	147.37	664.53...	2137.7...	474.42...	56.085...	0.3201...	4500510	-21256...	2107.8...	2127.9...	1543.6...	123395...	57.037...
F03-4	623265...	608257...	147.37	664.53...	2137.7...	474.42...	56.085...	0.3201...	4500510	-21256...	2107.8...	2127.9...	336.53...	504850...	38.807...
F03-4	623239...	608259...	147.37	664.53...	2137.7...	474.42...	56.085...	0.3201...	4500510	-21256...	2107.8...	2127.9...	2301.2...	654806.5	22.091...
F03-4	623265...	608257...	147.6	665.53...	2150.4...	467.20...	58.785...	0.3121...	4626120	14698...	2140.7...	2129.7...	316.47...	507516...	38.769...
F03-4	623255...	608259...	147.6	665.53...	2150.4...	467.20...	58.785...	0.3121...	4626120	14698...	2140.7...	2129.7...	1475.7...	123343...	55.861...
F03-4	623239...	608259...	147.6	665.53...	2150.4...	467.20...	58.785...	0.3121...	4626120	14698...	2140.7...	2129.7...	2305.5...	647528...	21.964...
F03-4	623239...	608259...	147.83	666.53...	2177.9...	451.61...	62.35	0.2950...	4824330	52805...	2214.2...	2131.5...	2306.0...	640624...	21.885...
F03-4	623255...	608259...	147.83	666.53...	2177.9...	451.61...	62.35	0.2950...	4824330	52805...	2214.2...	2131.5...	1408.5...	123296...	54.644...
F03-4	623265...	608257...	147.83	666.53...	2177.9...	451.61...	62.35	0.2950...	4824330	52805...	2214.2...	2131.5...	296.79...	510159...	38.733...
F03-4	623239...	608259...	148.07	667.53...	2159.3...	462.21...	60.929...	0.3066...	4679120	91507...	2163.5...	2133.4...	2489.9...	693416...	22.222...

**Workflow cont'd:**

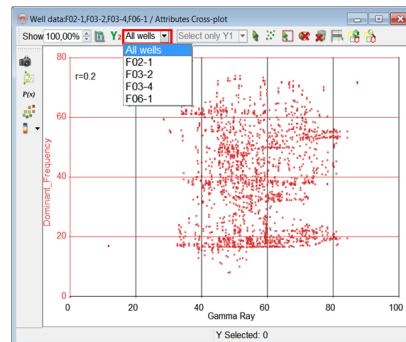
14. By default, it will plot scattered points of all wells vs. selected attribute(s). **Select** one well from the combo-box to cross-plot an individual well.



**Additionally:**  
Repeat the steps 12 to 14 by selecting exclusively logs for the X axis and for the Y axis. Optionally select consecutively two logs to be displayed on the Y axis. The second log will be displayed as Y2.

When selecting different X and Y quantities in the table, the crossplot display window will be automatically updated. Use the  and  arrows to change the Y column to the next (or previous) column.

## 2.3.2c Bodies

Required licenses: OpendTect Pro, Faults & Fractures.

### Exercise objective:

Create and rank fault bodies from a fault discontinuity attribute volume.

### Workflow:

1. **Click** on the Faults and Fractures icon .
2. In the Faults and Fractures control center: **Select** Voxel Connectivity tool in the Planes module.
3. **Press** Go.

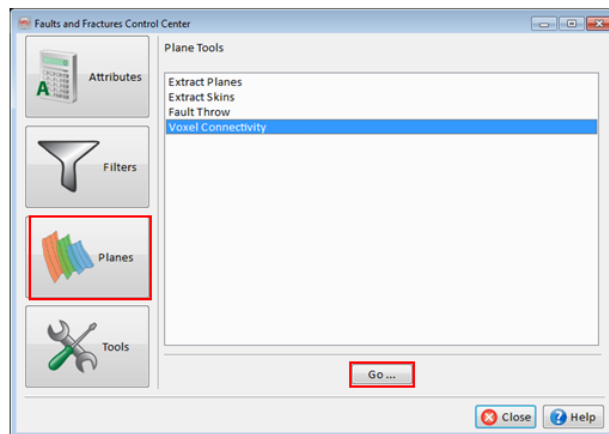

### Workflow cont'd:

4. **Define** the first step:
  - a. **Select** `Fault_Likelihood_Thinned_from_DSMF_seis` as Input Cube
  - b. **Give** a Name for this step and **click** Ok.

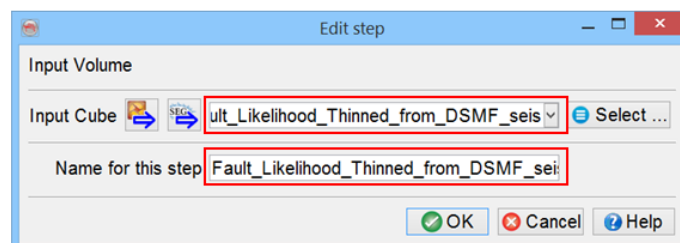



**Workflow cont'd:**

5. **Define** the second step:
  - a. **Select** the Voxel Connectivity Filter step and click on .
  - b. In the Edit step window, **Keep Values larger than 0.6**.
  - c. **Set** the body size threshold to 100.
  - d. **Set** the Kept output to Body-size.
  - e. **Give** a Name for this step.
  - f. **Click** on OK.

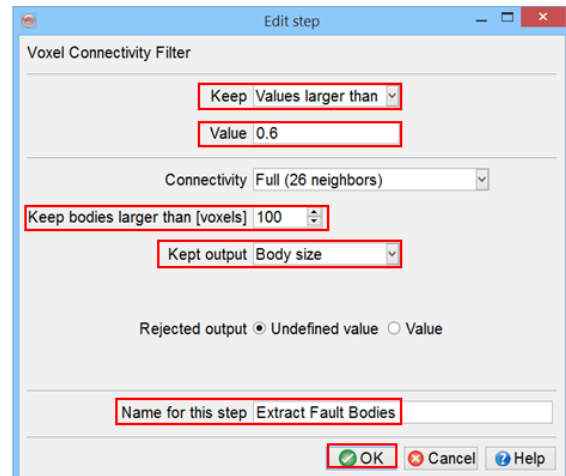



*Voxel Connectivity Filter* is a special tool to create continuous bodies based on the amplitudes in a stored volume. A voxel is defined as the volume around one sample. It is thus linked to the survey bin size and sampling rate.

**Workflow cont'd:**

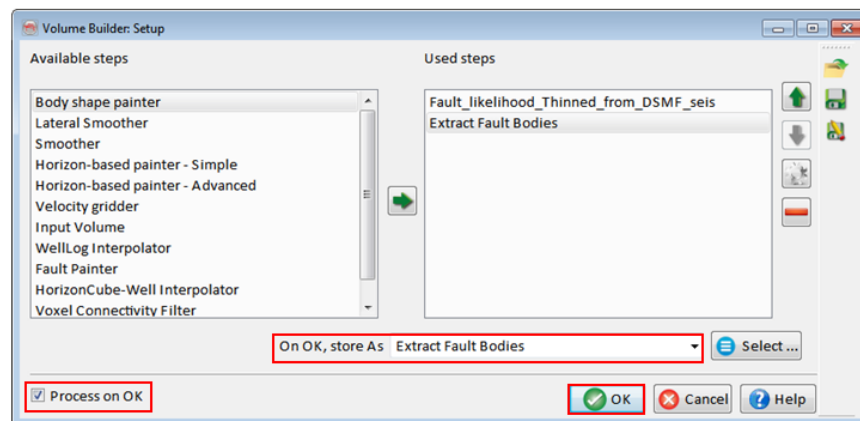
6. In the next Volume builder main window, **give** a name to the Volume builder setup.
7. Make sure the box Process on OK is **toggle**d on and **press** OK.



If the Process on OK box is toggled on, pressing OK will prompt you to save the Volume Builder setup and specify an output volume name. You can also save and retrieve setups with the icons:  and . Processing is then started from the Processing menu, option Volume Builder ...

**Workflow cont'd:**

8. In the Create output window, the active Volume Builder setup is selected by default.
9. **Reduce** the volume to process: **press** Select and **specify** Inline, Cross-line and Time ranges as shown.
10. **Specify** a name for the Output cube and **press** OK.

In-line Range	120	400
Cross-line Range	350	600
Time Range (ms)	1400	1848

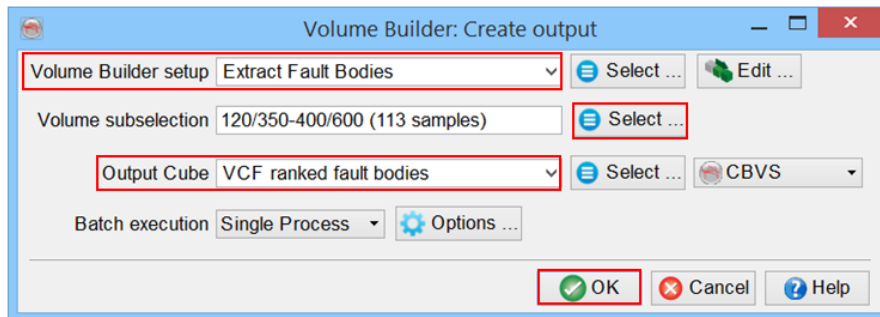

**Workflow cont'd:**

11. To display the created volume, **click** on Volume in the tree and **select** Add to add a volume viewer to the 3D scene.
12. Click on the new tree item and go to Display > position. **Set** the viewer to the ranges specified in the previous slide either using the menu. Alternatively use the  icon.

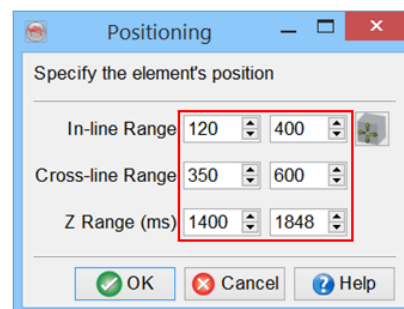
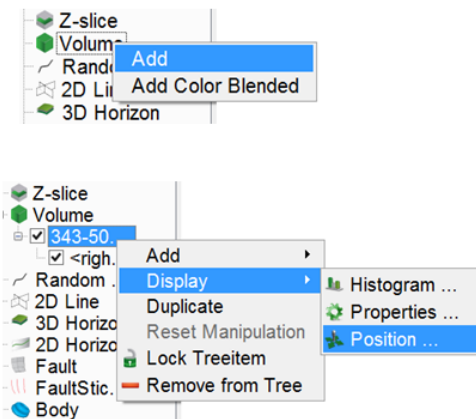

**Workflow cont'd:**

- 13. **Select** the volume you just created in the pop up window and **click** Ok.
- 14. **Select** a color bar (e.g. *Extremes*). Adjust transparency as needed and ensure that undefined values are displayed with 100% transparency.

To edit the colorbar: see Exercise 1.2.2

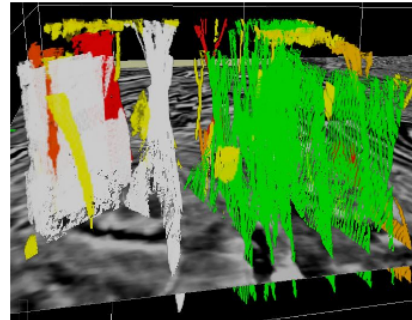
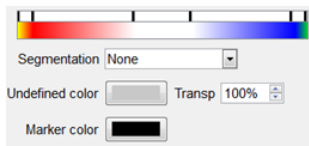
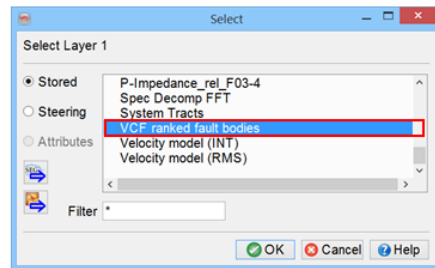

## 2.3.2d Planes

Required licenses: OpendTect Pro, Faults & Fractures.

### Exercise objective:

Extract fault planes from a Fault Likelihood volume.

### Workflow:

1. **Click** on the Faults and Fractures icon .
2. In the Faults and Fractures control center: **Select** Extract Planes under the Plane category.
3. **Click** on Go.

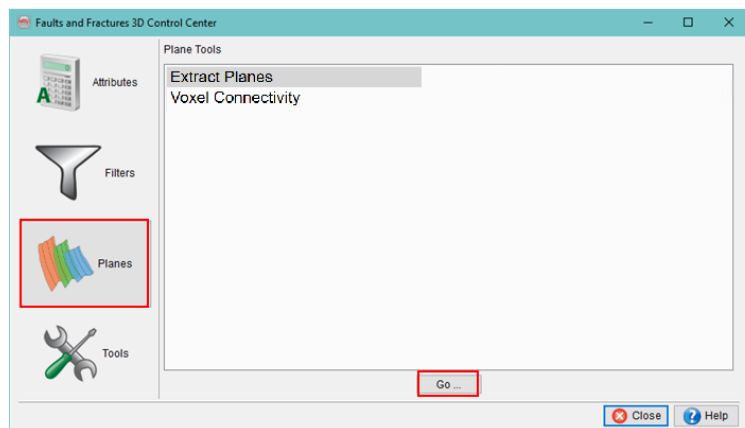

### Workflow cont'd:

4. In the Fault Skin Processing settings window **create** an input Fault Likelihood cube.

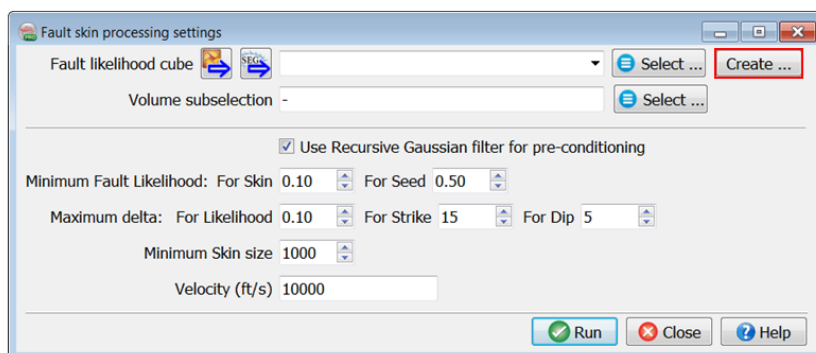

**Workflow cont'd:**

5. Select 4 Dip steered median filter cube and keep the processing parameters by default.
6. **Restrict** the volume subselection to inline 100-400, crossline 300-750, z range 1400-1848.

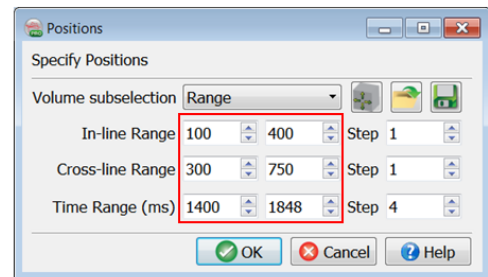
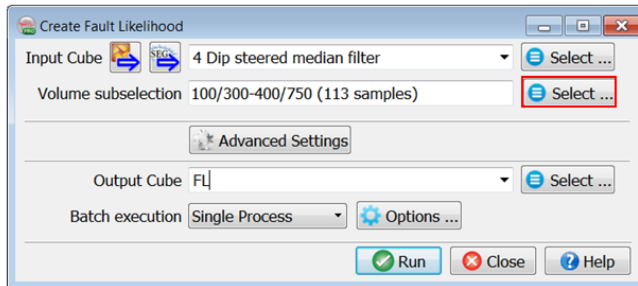

**Workflow cont'd:**

7. **Select** the processed Fault Likelihood volume.
8. Press **Run** to extract fault skins.

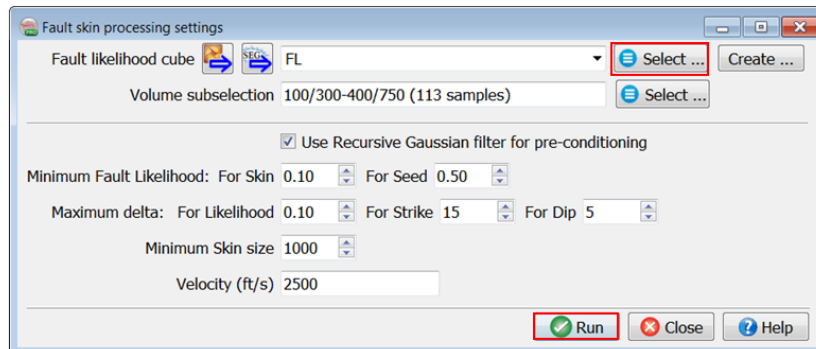

**Workflow cont'd:**

9. A set of fault skins is now displayed in the 3D scene along with Fault skin QC window.

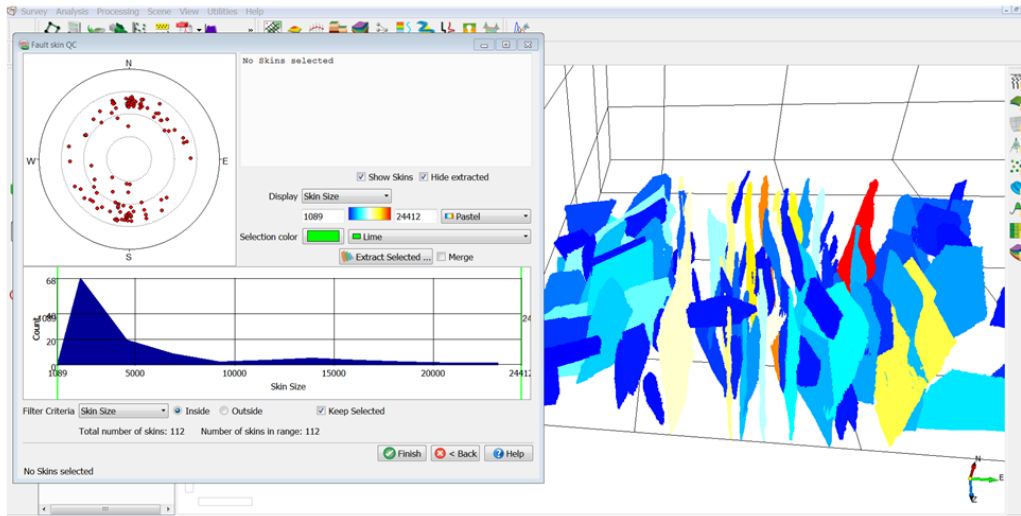

**Workflow cont'd:**

10. Select an individual fault by clicking on a skin (it turns green) and Extract Selected as an individual fault plane.

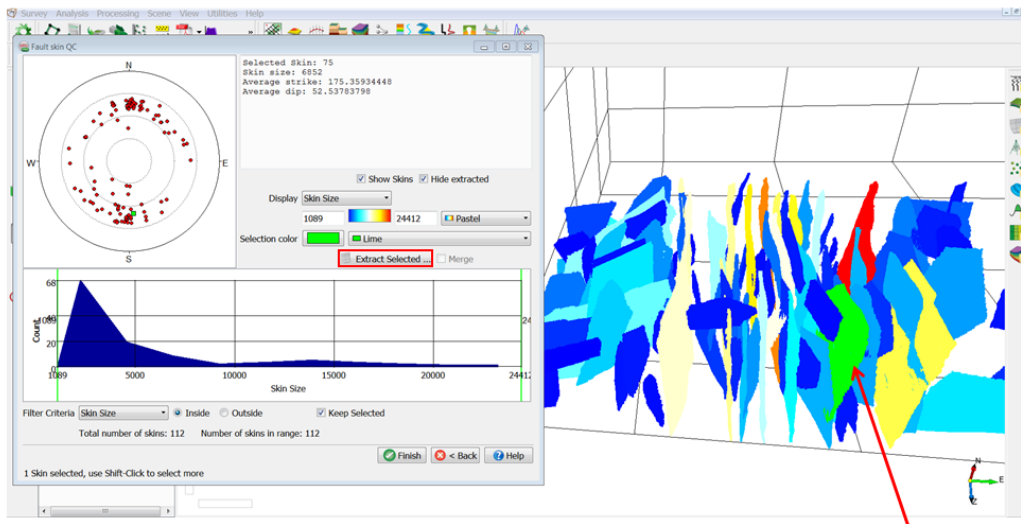

**Workflow cont'd:**

- 11. Select several skins using Shift + left mouse click.
- 12. Check the Merge option and extract the skins as one fault.

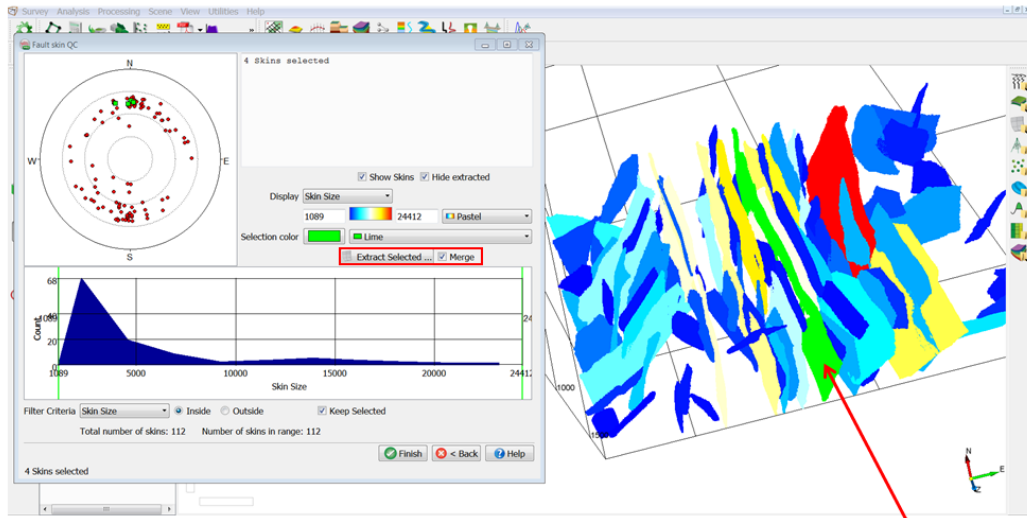

**Workflow cont'd:**

- 13. Select all skins using Ctrl+A.
- 14. Extract all skins as a Fault Set.

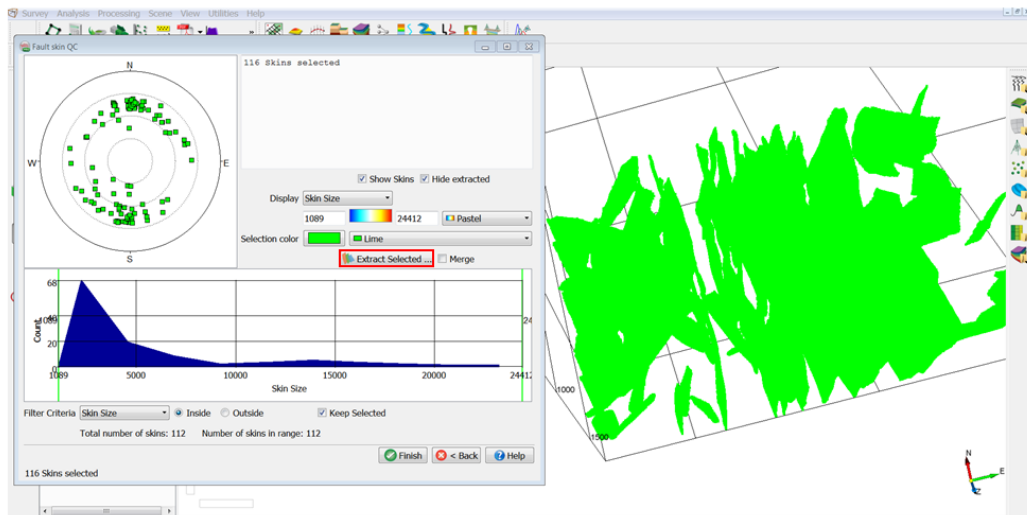

## 2.3.6a Waveform Segmentation - Quick UVQ

Required licenses: OpendTect Pro, Neural Networks.

### Exercise objective:

Visualize seismic pattern on a mapped horizon using Quick UVQ waveform segmentation.

### Workflow:

1. **Right-click** on 3D Horizon in the tree > Load... > **Choose Demo1** → MFS4.

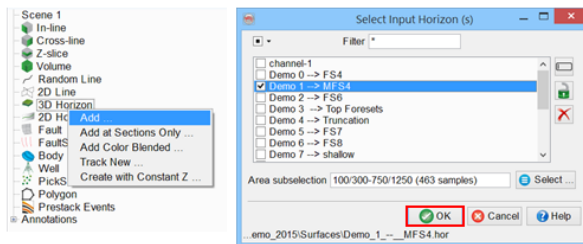

2. In the tree, **right-click** on Demo1 → MFS4 > **Workflows** > **Quick UVQ**.

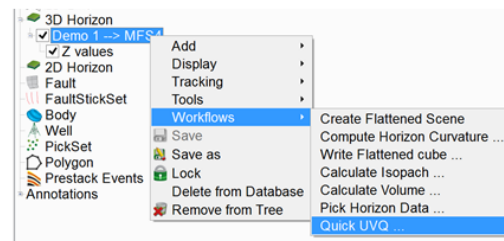

### Workflow cont'd:

3. In the Input Cube field the default *4 Dip steered median filter* volume is already selected.
4. Number of classes describe how many clusters the waveforms will be divided into.
5. The time gate describes the investigation window.
6. Optionally, a polygon can be used for sub-selection. Also, the neural network can be saved to disk.
7. **Click OK** to train a neural network and produce results.

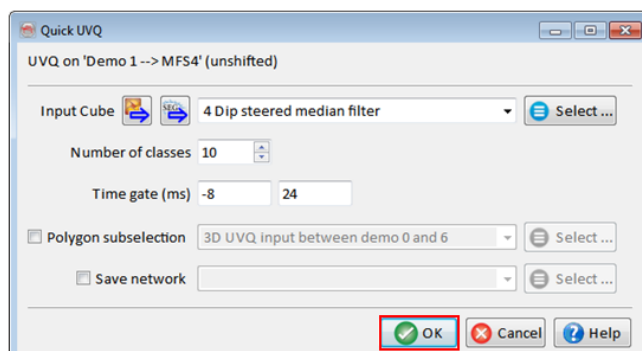

In practice, we always predict less number of classes (e.g. 5) to get a regional understanding of a depositional system. We then increase the number of classes to predict details.

Time gate can be adjusted relative to a horizon. In this case, -8ms is used considering a horizon is not perfectly snapped to a peak/trough. The focus is mostly below the horizon by setting 24ms.



**Workflow cont'd:**

8. A NN training window will pop-up. If the training is above 90% and flat, then you can **press** OK button.

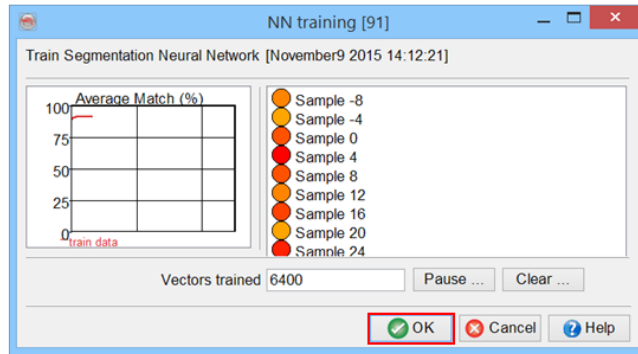

It will start applying the results on the input horizon.

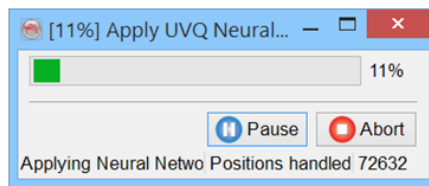

**Workflow cont'd:**

9. Once the NN processing is finished, you will see a NN Info window and two grids, (Class and Match) which are already displayed on the horizon.

**Tip:** If you are satisfied, you may want to save them as Horizon Data by right-clicking on each of them.

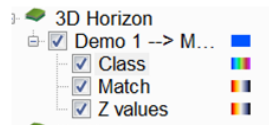

10. **Click** Display... to show class centers and **Close** the Info window.

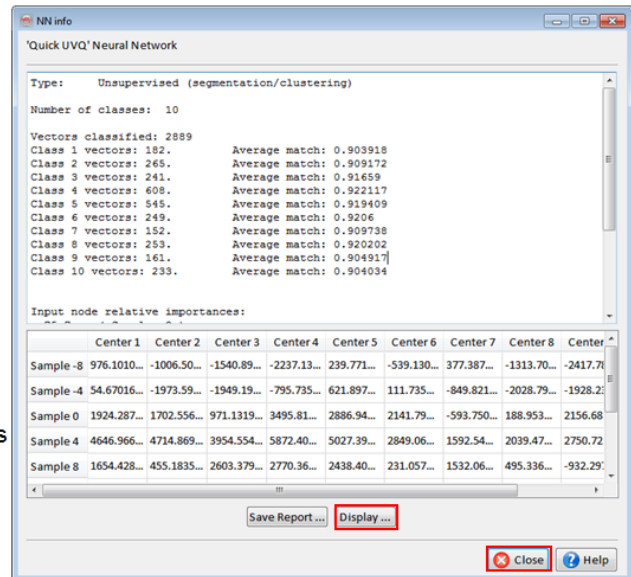

**Workflow cont'd:**

11. To match the colors, **click** on the Class grid, and choose Rainbow color bar.
12. Optionally, **click** on the color-bar icon in the class center if you want to change the color scheme there also.

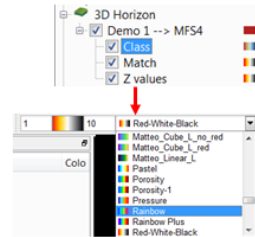

Colors are not matching....

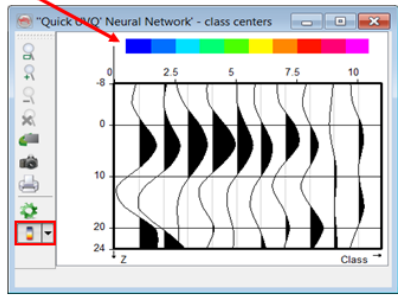
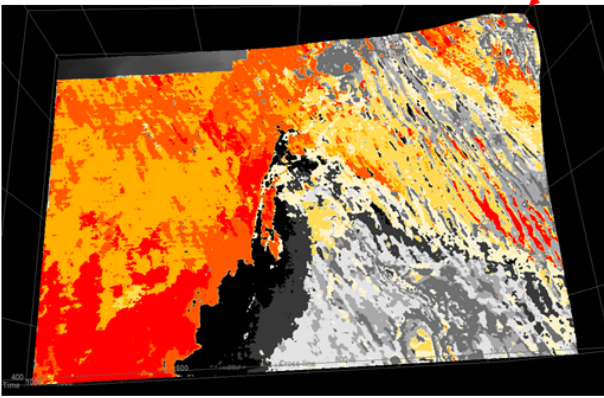

**Workflow cont'd:**

13. Your results may look like this.

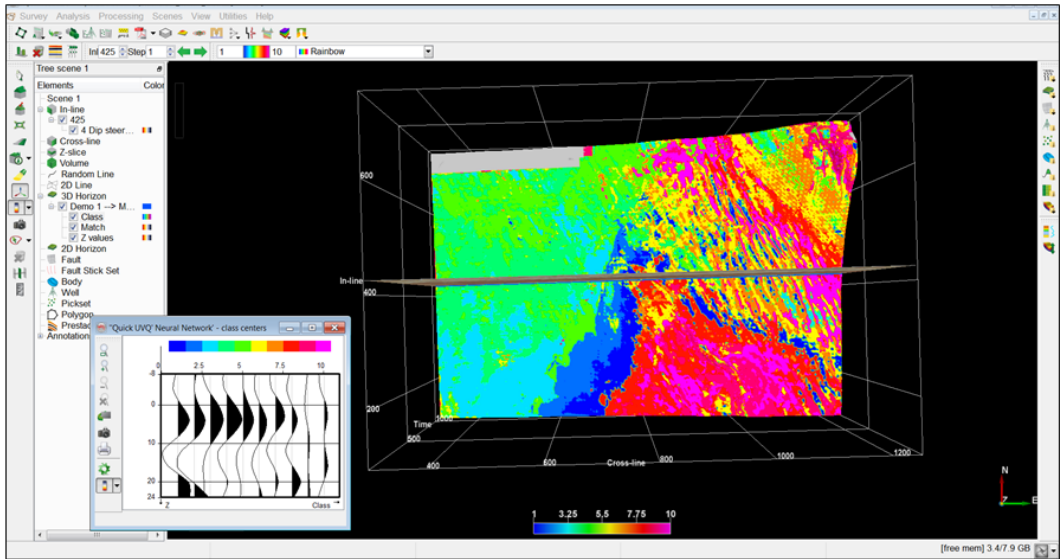

For segmented results such as UVQs, we prefer to use a segmented color bar. You can always change a color bar through manager (Survey > Manage > Colour tables).



## 2.3.6b Waveform Segmentation - Standard UVQ

Required licenses: OpendTect Pro, Neural Networks.

### Exercise objective:

Visualize seismic patterns on a mapped horizon using the standard unsupervised neural network method

### Workflow:

1. **Open** the Attribute set window  and select the default attribute set  named Workflow - Unsupervised Waveform Segmentation.
2. It will pop up a window asking to provide Input Seismics, the default volume is automatically selected. **Press** OK.

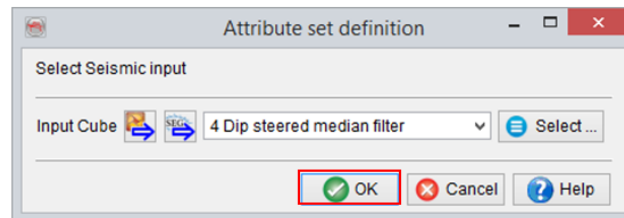

This default attribute set is designed to extract each samples within the time window [-100,+200]ms (with a step equal to the z step of the survey) regarding the application sample.

**Uncheck** Save on Close and close the Attribute Set 3D window.

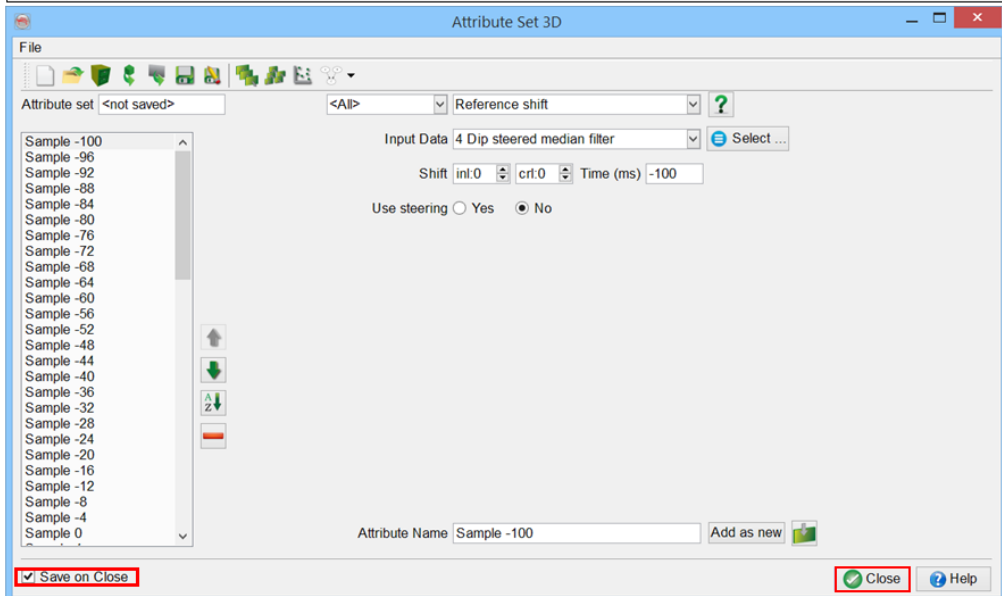

**Workflow cont'd:**

3. **Start** the 3D Neural Network plugin by clicking the  icon.

4. **Select** the option Pattern recognition [PickSets].

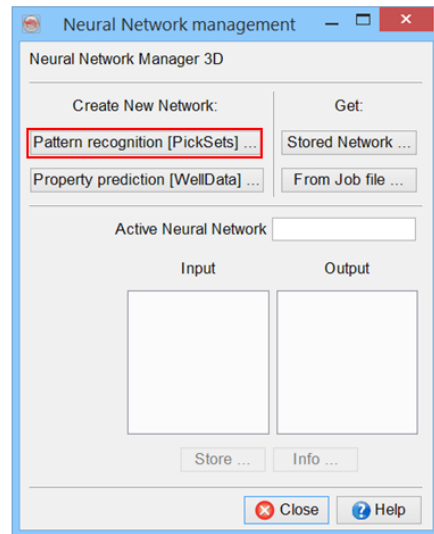

**Workflow cont'd:**

5. **Set** the analysis method to Unsupervised.

6. **Select** Samples within the window [-8,24]ms.

7. **Click** on Create button... to generate a random pickset.

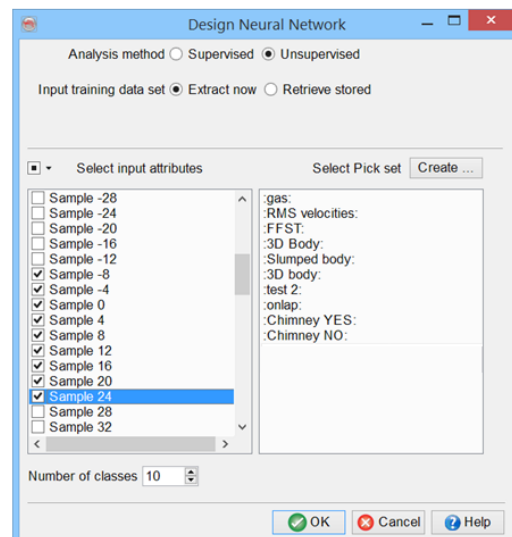

**Workflow cont'd:**

8. **Create** a pickset containing 1000 picks along the horizon *Demo1* → *MFS4*.
9. **Click** OK.

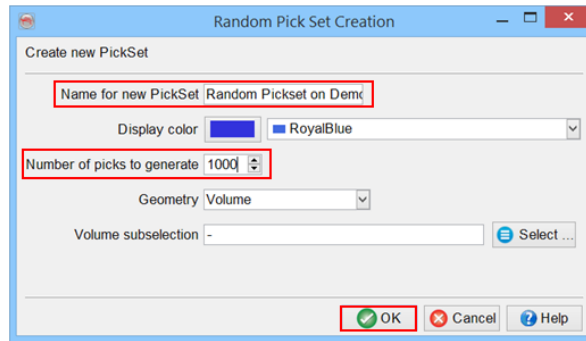

**Workflow cont'd:**

10. The pickset will appear in the list. Make sure that the correct set is selected.
11. **Click** OK.

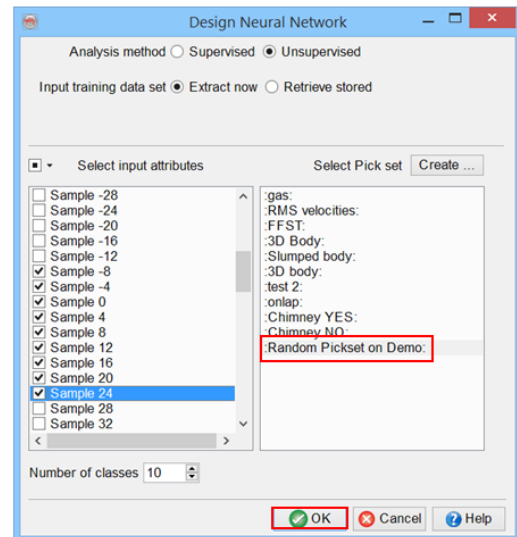

**Workflow cont'd:**

12. A spreadsheet with statistics will pop up. **Click** on Run.

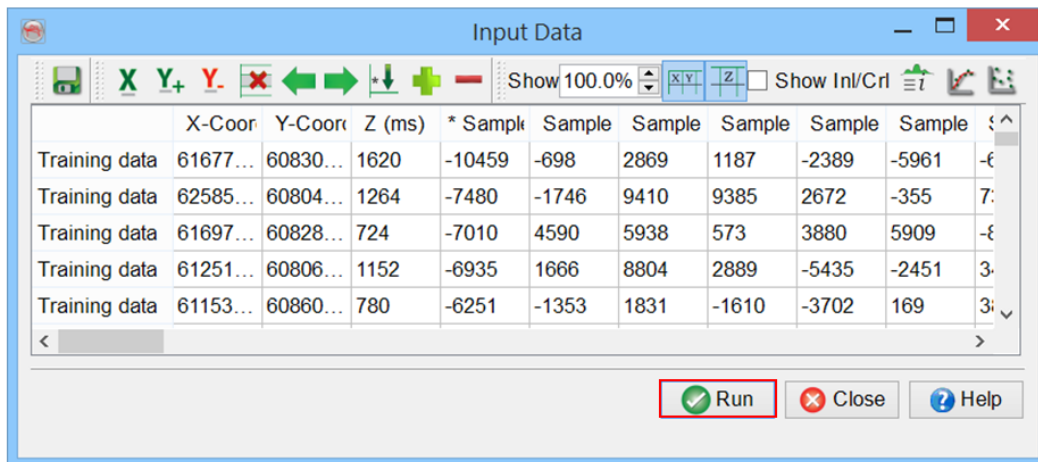

**Workflow cont'd:**

13. This will start the neural network training. After the Average Match curve becomes flat, **click** on OK. Training with a 90% (match) is considered as a good prediction.

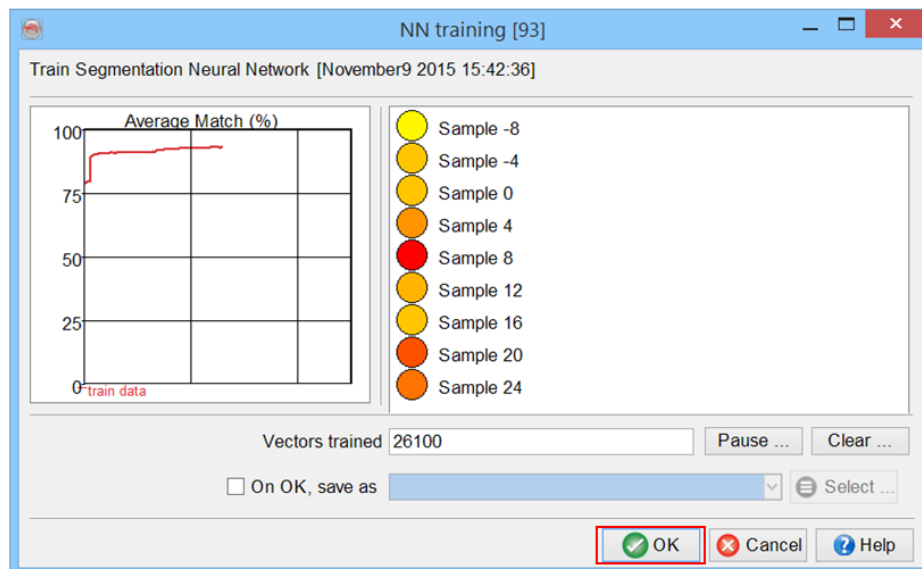

**Workflow cont'd:**

14. The trained neural network is now active, with appropriate input and output.

15. **Click** on Store .. to save the neural network to disk.

16. **Click** on Info...

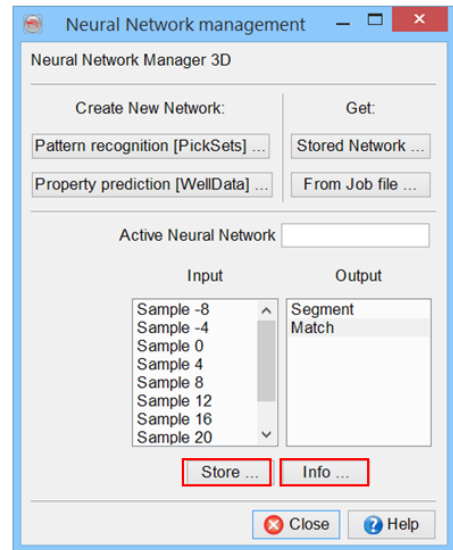

**Workflow cont'd:**

17. NN info window will pop up.

18. **Click** on Display to show Class Centers.

19. **Close** the NN info and the NN Management windows.

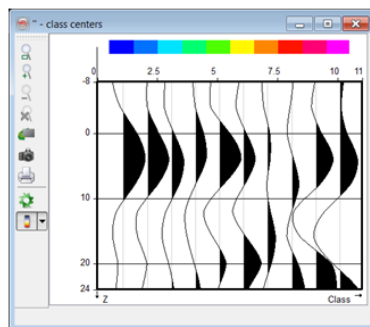

Type: Unsupervised (segmentation/clustering)  
 Number of classes: 10  
 Vectors classified: 395  
 Class 1 vectors: 0. Average match: 0  
 Class 2 vectors: 0. Average match: 0  
 Class 3 vectors: 0. Average match: 0  
 Class 4 vectors: 0. Average match: 0  
 Class 5 vectors: 0. Average match: 0  
 Class 6 vectors: 0. Average match: 0  
 Class 7 vectors: 0. Average match: 0  
 Class 8 vectors: 1. Average match: 0.914304  
 Class 9 vectors: 242. Average match: 0.889932  
 Class 10 vectors: 152. Average match: 0.852083

	Center 1	Center 2	Center 3	Center 4	Center 5	Center 6	Center 7	Center 8	Center 9	Center 10
Sample -100	-1049...	-1300...	-1123.5...	-899.8...	-1689...	-1202...	-442.8...	18.569...	-222.1...	571.72...
Sample -96	-40.10...	-628.9...	411.93...	518.22...	954.23...	877.26...	455.63...	1764.5...	-72.03...	347.22...
Sample -92	-1903...	-306.0...	-738.5...	-948.1...	-1312...	-1876...	552.48...	2.9334...	-73.05...	164.35...
Sample -88	-4134...	-2480...	-2090...	-4127...	-4037...	-4148...	-3620...	-130.8...	-325.2...	330.23...
Sample -84	-2163...	-1865...	-2520...	-3813...	-4273...	-4483...	-2036...	793.79...	-106.6...	-238.7...
Sample -80	1092.9...	500.38...	-44.23...	252.65...	1.3900...	644.92...	154.18...	2720.4...	534.54...	-1182...

**Workflow cont'd:**

20. **Add** a 3D horizon *Demo1* → *MFS4* in the tree. **Apply** the neural network to the horizon by **right-clicking** on the horizon name in the tree > Add > Attribute.

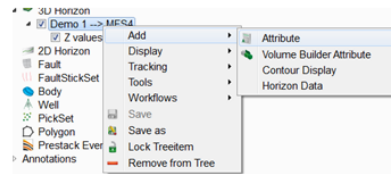

21. When prompted to select data, select *Segment* attribute from Neural Network tab.

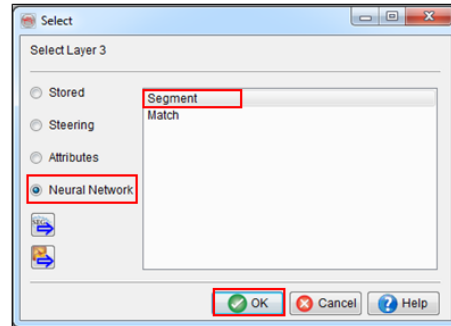

22. As *Segment* appears in the tree **change** the color bar to *Rainbow*.

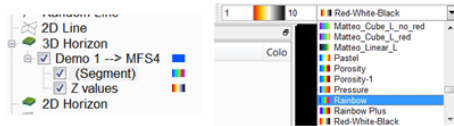

**Workflow cont'd:**

23. Your results may look like this.

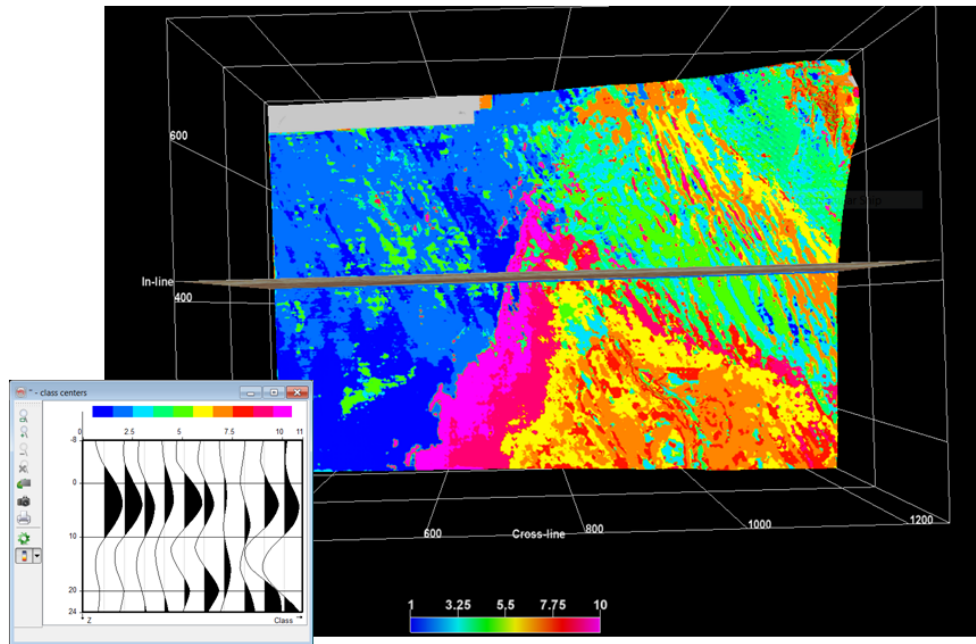





## 2.3.6c ChimneyCube

Required licenses: OpendTect Pro, Dip-steering, Neural Networks.

### Exercise objective:

Create a ChimneyCube with the supervised Neural Network approach.

### Workflow:

1. **Open** the attribute editor using the  icon and open the default attribute set *NN ChimneyCube* via the  icon and **click** on Ok.

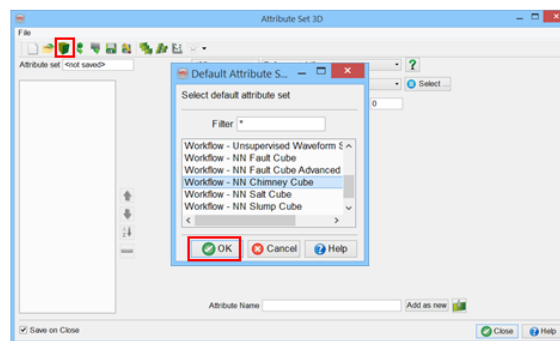
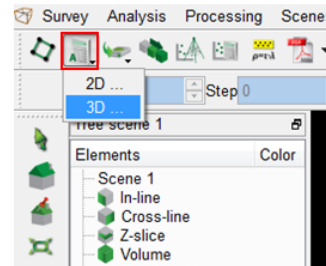

### Workflow cont'd:

2. A pop up message will **prompt** for seismic and steering data. Please select *4 Dip steered median filter* for *seismics* and *2 Steering BG Detailed* for *steering Data* and **click** on Ok and **close** the Attribute window.

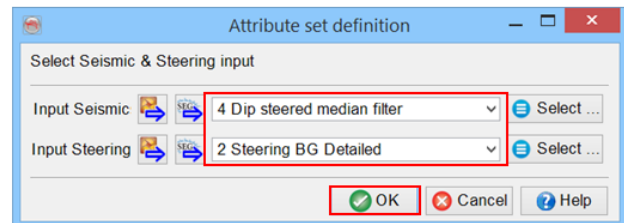

The attributes in this set should help differentiate *chimneys* and *background noise*. Visual inspection of the data shows chimneys present around inline 290 and 690. The chimneys appear as vertical noise trails

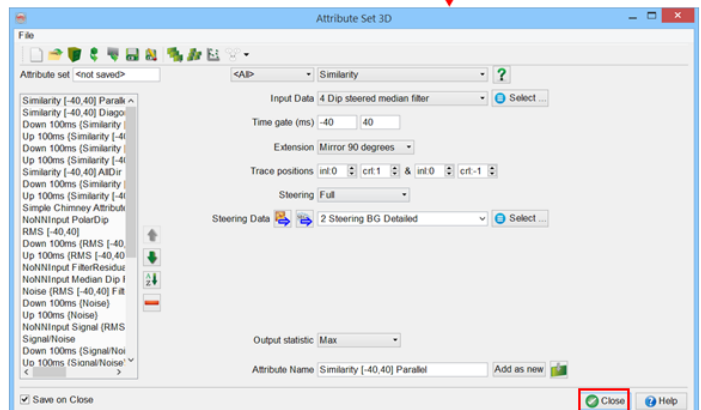

**Workflow cont'd:**

3. **Save** the Attribute set as *NN ChimneyCube Training* and **click** on Ok.

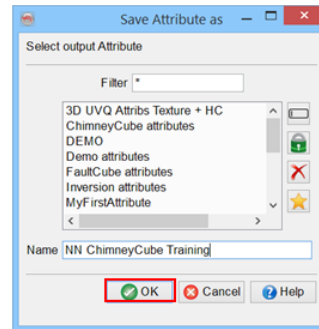

4. **Add** default data (i.e. *4 Dip steered median filter*) by **right-clicking** on inline.

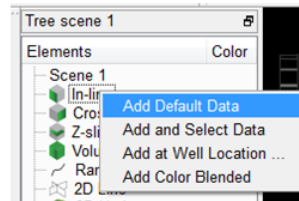

5. **Click** on the added inline number 425 and **change** it to 690 by entering it in the Inl box.

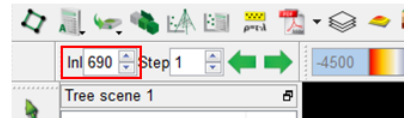

**Workflow cont'd:**

6. In order to **pick** chimneys and differentiate them from the background noise, two picksets are needed.

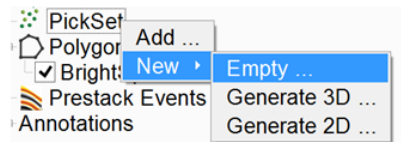

7. **Click** on Pickset in the tree > New Pickset > Empty. In the pop-up you will give a name to this as *Chimney\_Yes*.

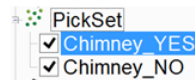

8. **Repeat** the Step 7 and create another pickset called *Chimney\_NO*.

**Workflow cont'd:**

9. **Highlight** the *Chimney YES* pickset and **pick** locations in the scene that appear as chimneys.
10. **Repeat** the process for the *Chimney NO* pickset, **pick** locations where chimneys are not expected. **Save** both picksets by **right-clicking** on their names.
11. Scroll to another inline using the  icons to make more picks. **Save** both picksets.

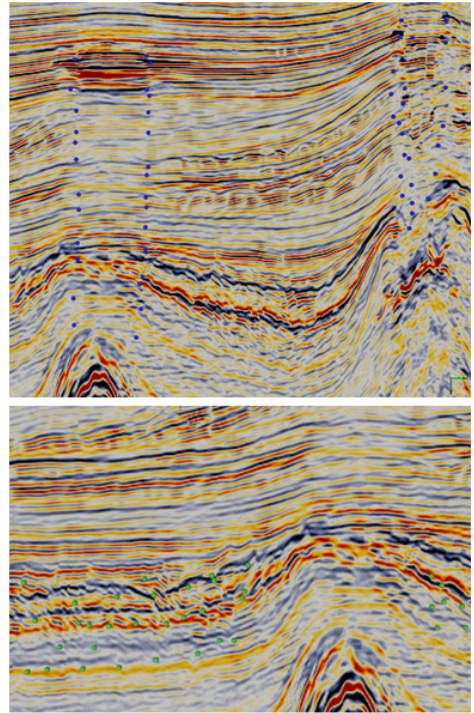

**Workflow cont'd:**

12. **Open** the 3D neural network by clicking on the  icon.
13. **Click** on Pattern recognition.

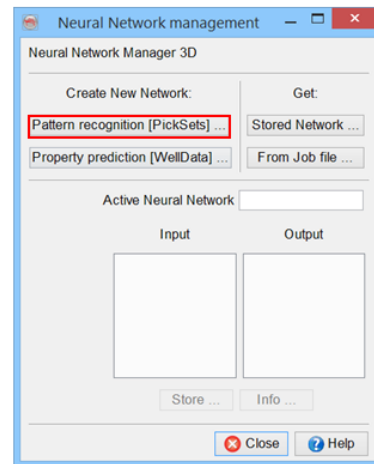
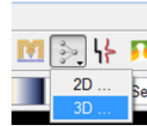

**Workflow cont'd:**

14. **Set** Analysis method to Supervised. **Deselect** attributes with prefix "*NoNN*" from the list. Select *Chimney\_Yes* and *Chimney\_No* picksets made by you. **Specify** 30% of the data for test set and **press** OK.

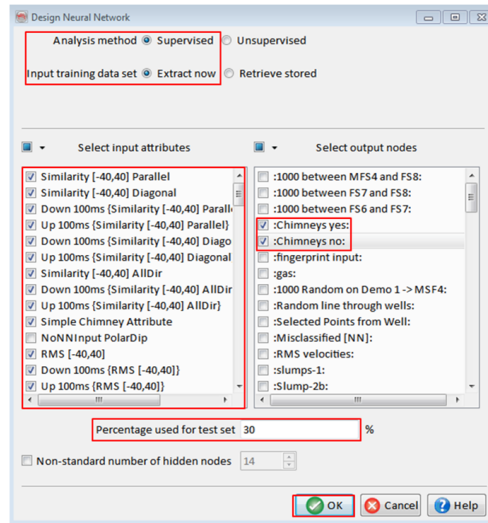

**Workflow cont'd:**

15. A spreadsheet with statistics will pop up, here you may edit and analyze the attributes by cross-plotting them against the *Chimney YES* and *NO* picksets. After investigating, **click** Run.

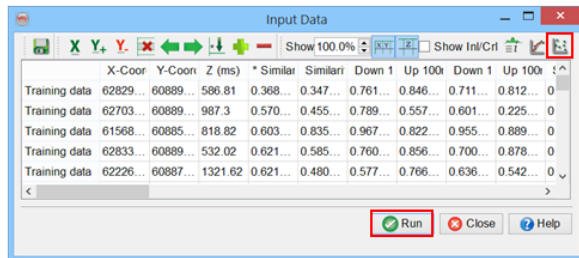

16. The neural network training will begin.

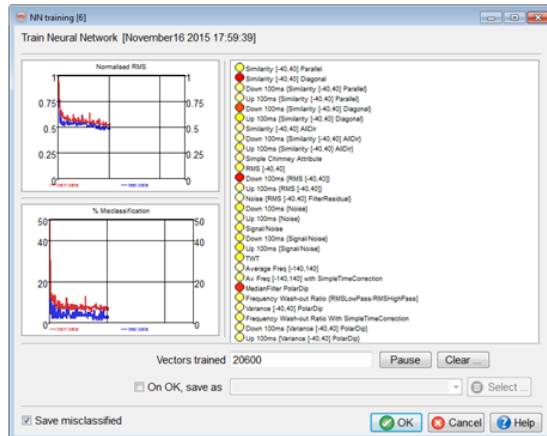

**Workflow cont'd:**

17. As the training of the neural network runs, the normalized RMS and % Misclassification curves will decrease. In order to avoid overtraining of the neural network, **click** OK as soon as the normalized RMS curve becomes flat.
18. If the training graphs become flat and are not changing, you may proceed and **click** OK button.

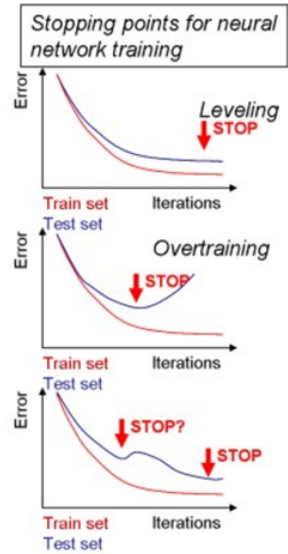
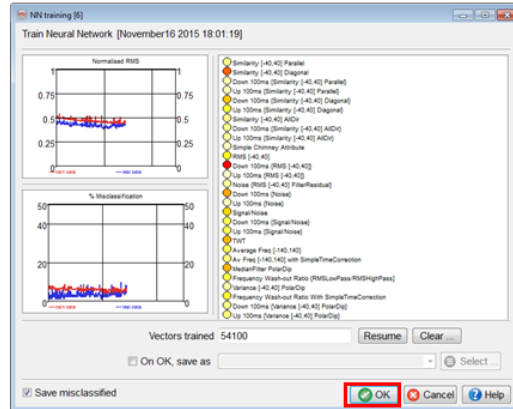

**Workflow cont'd:**

You can press clear to restart the training, for example if the neural network becomes over-trained

The colors of the input attributes change during the training. The colors reflect the weights attached to each input node and range from white via yellow to red. Red nodes have the most weights attached and are thus more important to the network for classifying the data.

Colors are very useful indicators on how to tune a network and discard attributes that may take up a lot of CPU time without contributing to the final result

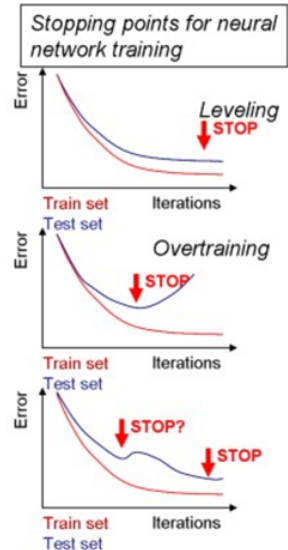

**Workflow cont'd:**

- 19. Optionally, **Store** the Neural Network (you will need to provide a new name).
- 20. **Close** the Neural Network Management window.
- 21. **Test** the training results on your data. Add the neural network attribute named *Chimney YES* by **right-clicking** an inline (e.g. inline 690) in the tree.

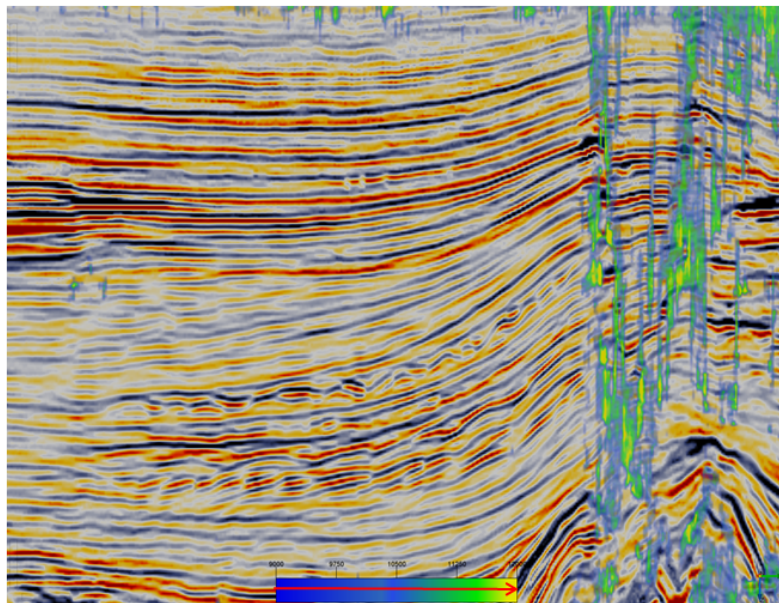
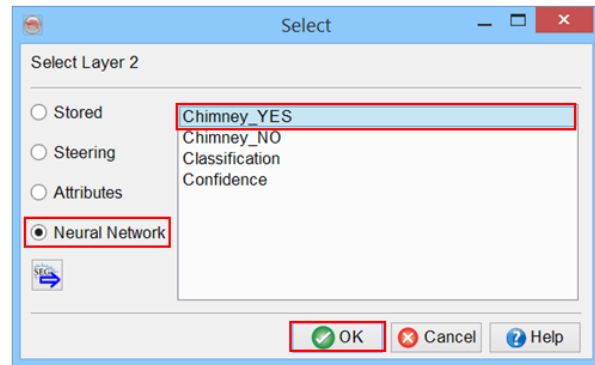
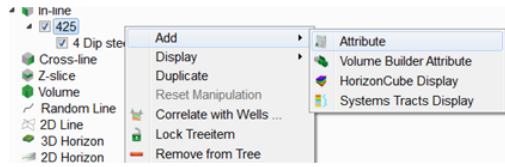
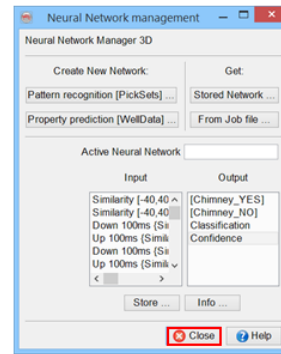

Example of chimney display on inline 690. The red arrow indicates increased likelihood of chimneys.

**Workflow cont'd:**

22. If you are not satisfied with the output, go back and **change** the location of your picks using the *Misclassified NN* pickset (generated automatically) by **right-clicking** *Pickset* in the tree

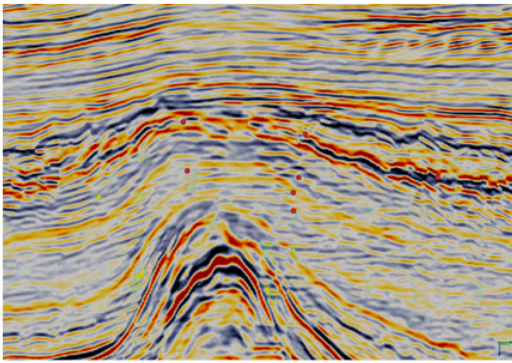
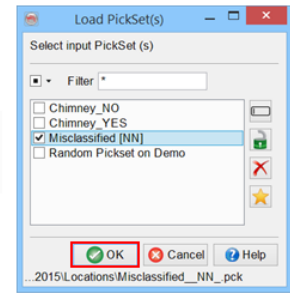
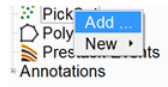

Misclassified NN pickset (in red) on inline 690

**Workflow cont'd:**

**Create Output Volume**

23. When satisfied with the results, the final step is to **output** the ChimneyCube volume as a seismic cube that is stored on disk via Processing > Create Seismic Output > Attributes > Single Attribute > 3D ...

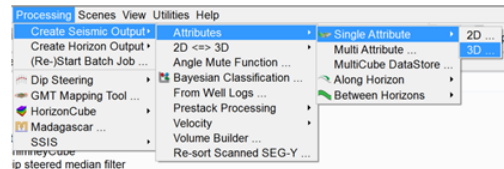

24. **Select** the *Chimney YES* attribute from the list, **give** the volume an appropriate name and **click** OK.

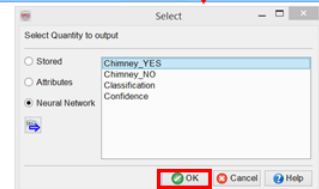
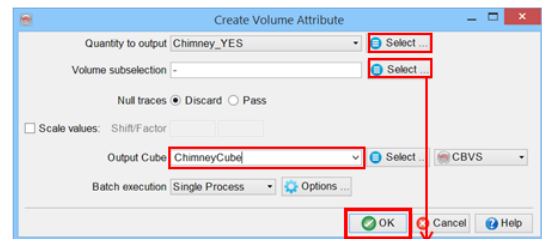

## 2.4.1a Data-driven HorizonCube

Required licenses: OpendTect Pro, Dip-steering, HorizonCube.

### A – Tracking based data-driven HorizonCube

#### Exercise objective:

Create a continuous, data-driven HorizonCube in order to understand the depositional history of a prograding system using principles of seismic sequence stratigraphy.

#### Workflow:

1. **Go to** Processing > HorizonCube > 3D...
2. **Select** the Create a HorionCube option and **click** the Go.. button in the HorizonCube 3D Control Center.

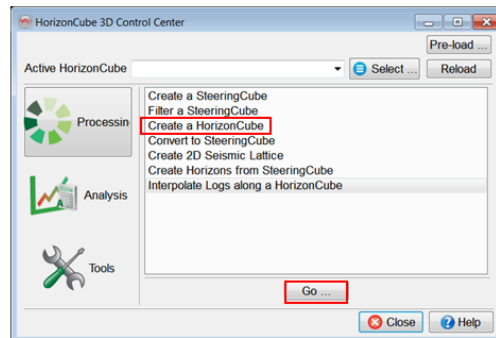
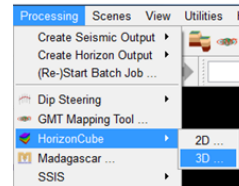

#### Workflow cont'd:

3. **Select** the horizons *Demo 0* → *FS4*, *Demo 4* → *Truncation* and *Demo 6* → *FS8*. **Click** on OK.

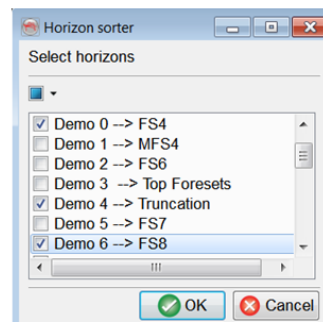



**Workflow cont'd:**

4. We will **create** a data driven HorizonCube in this exercise, i.e. the type that follows the SteeringCube. In Mode, **select** Data Driven: Tracking.
5. **Click** Settings... in the HorizonCube Creator 3D window.
6. **Set** the *Steering Data* to *3b FFT 225 MF113* and Start at to: Center. **Check** the Apply to all packages option and **click** OK.

Processing parameters include settings such as spacing at start position, number of iterations etc.

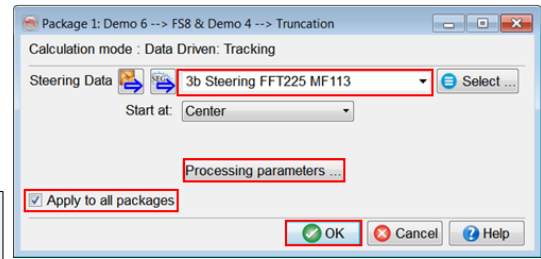
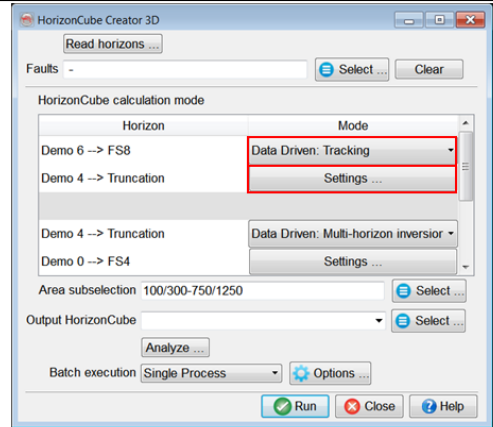

**Workflow cont'd:**

8. **Click** Select for Area subselection and **set** to inline range to 400 – 450. **Click** OK.
9. **Give** an appropriate name, e.g. *HorizonCube\_FFT225MF113*, in the Output HorizonCube field and **click** Run.

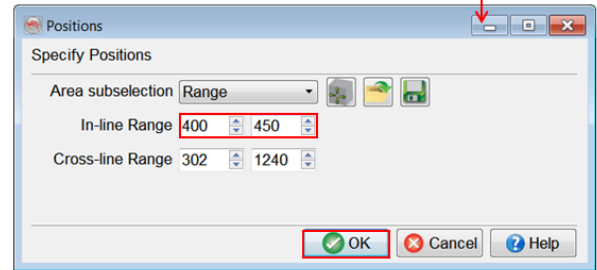
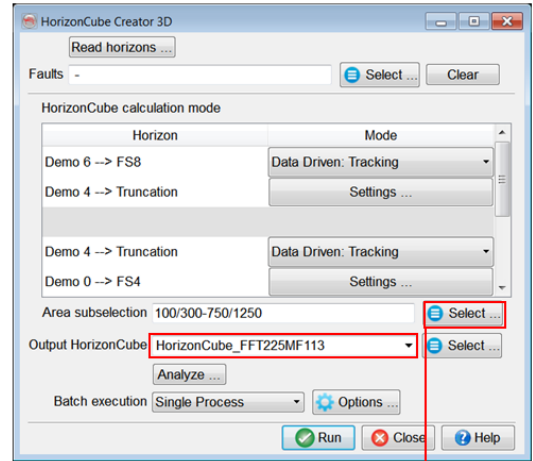

**Workflow cont'd:**

10. A Batch Processing window will pop up. Wait for the message **Finished Batch Processing** and close the window.

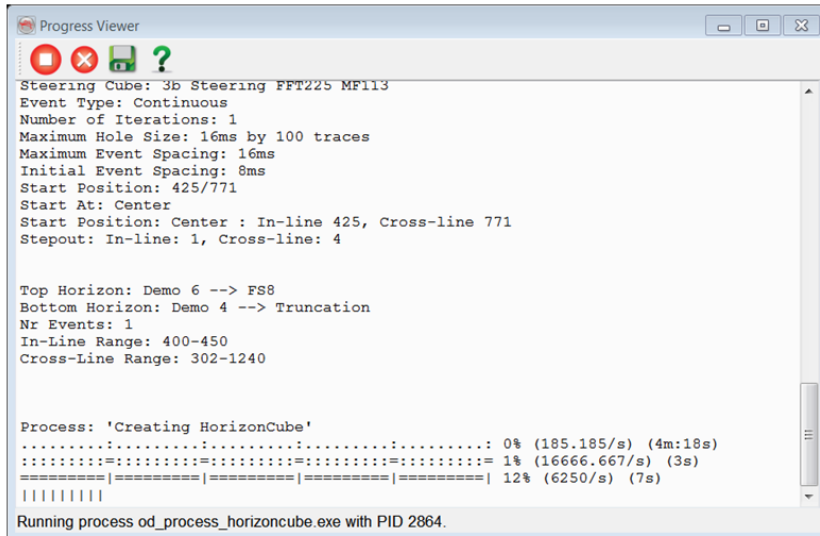

**Workflow cont'd:**

11. **Add** inline 425 in the scene and **select** the attribute *4 Dip steered median filter*.

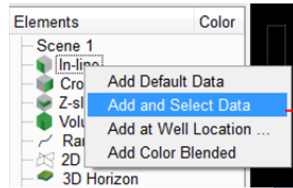

12. **Right-click** the inline number (i.e. 425) and **select** Add > HorizonCube Display

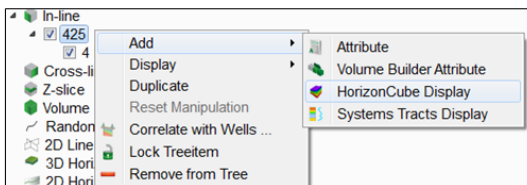
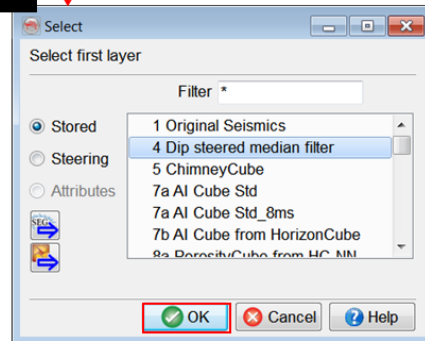

**Workflow cont'd:**

13. **Select** the *HorizonCube\_FFT225MF113* that you just created.

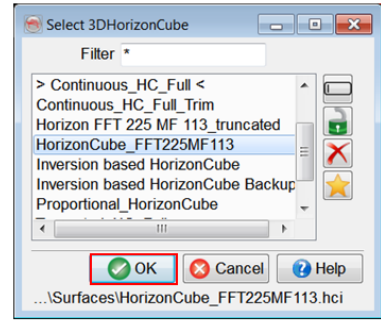

14. To explore HorizonCube display options **right-click** on the HorizonCube in the tree > Display > Properties. **Close** the window.

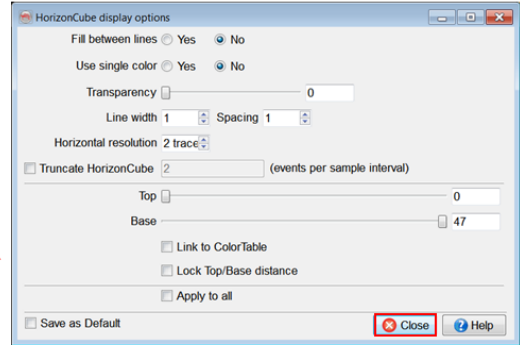
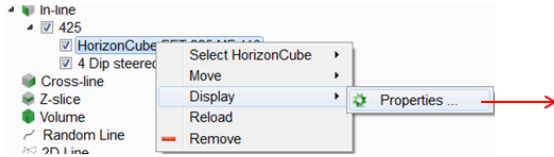

**Workflow cont'd:**

15. **Open** the HorizonCube slider by **clicking** the  icon.

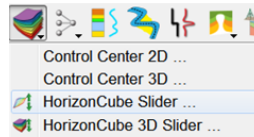

16. **Observe** and **QC** the results of your HorizonCube by using the Top and Base sliders.

The *HorizonCube slider* is a very useful tool to investigate your data and to make detailed observation of the depositional history of your sedimentary basin.

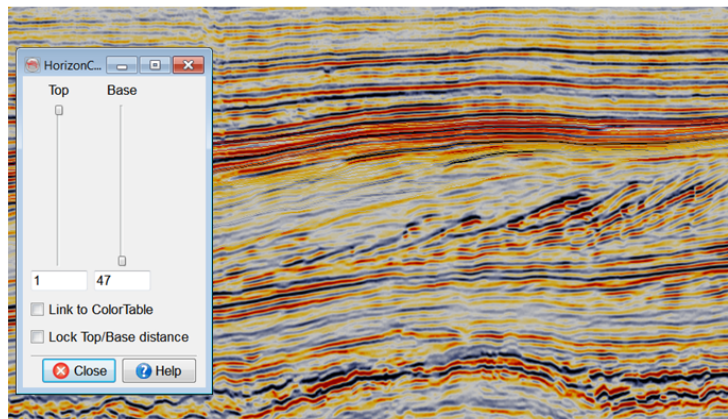

**Workflow cont'd:**

17. Observe how gaps are present in the prograding clinoforms. This is due to the HorizonCube being created with only one iteration. Iterations can be added later.

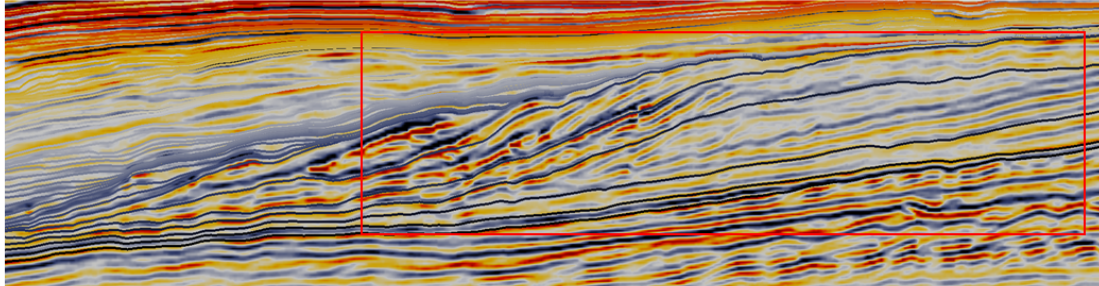

18. The gaps are filled by finding the gaps based on a given advanced setting. Advanced settings can be accessed by Processing > HorizonCube > 3D > Create > Settings > Processing parameters.

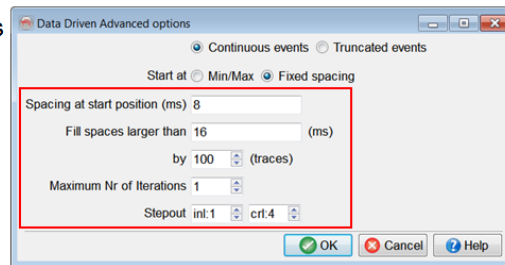

**Workflow cont'd:**

19. **Open** the HorizonCube 3D Control Center with the  icon.

20. In the Tools menu, **select** Add More Iterations and **click** Go.

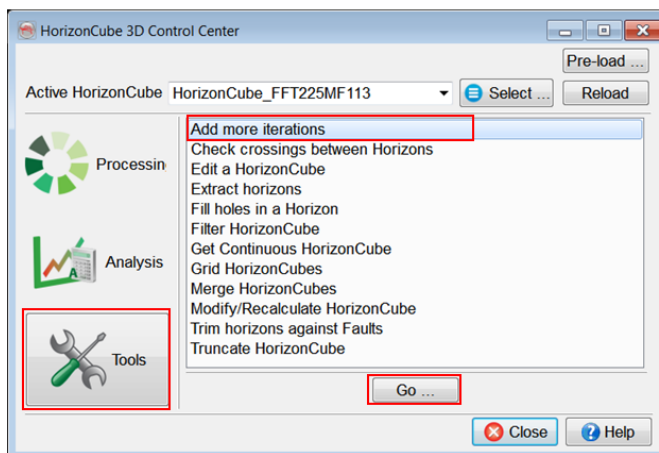

**Workflow cont'd:**

21. Leave the Extra Iterations option to 1, for each package.

22. **Save** with a new name, e.g. *HorizonCube\_FFT225 MF113\_2it*, and **click** OK.

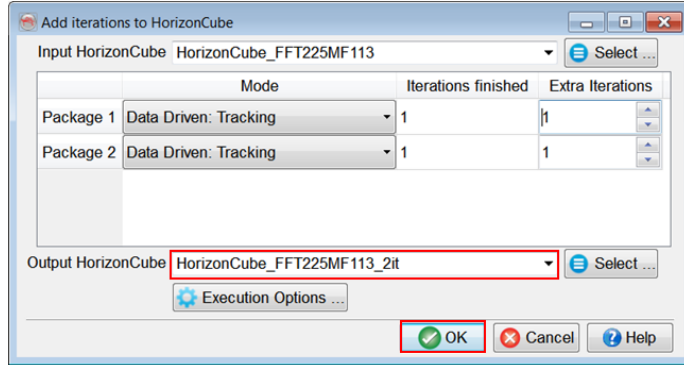

The first column Iterations finished shows how many iterations have already been processed. The tracked HorizonCube events from previous iterations will never change, only new events can be inserted between already existing ones

**Workflow cont'd:**

23. See the difference between output images of Iteration 1 and Iterations 2.

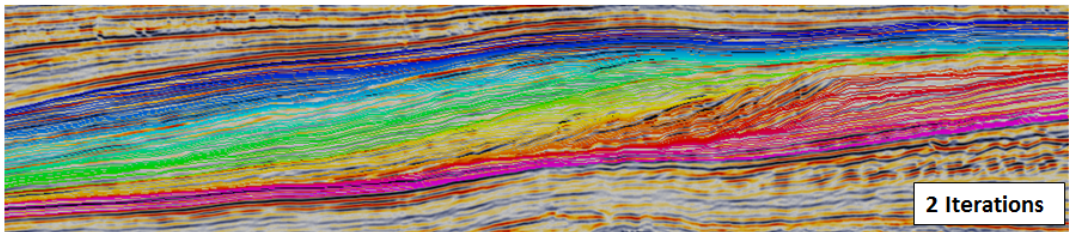
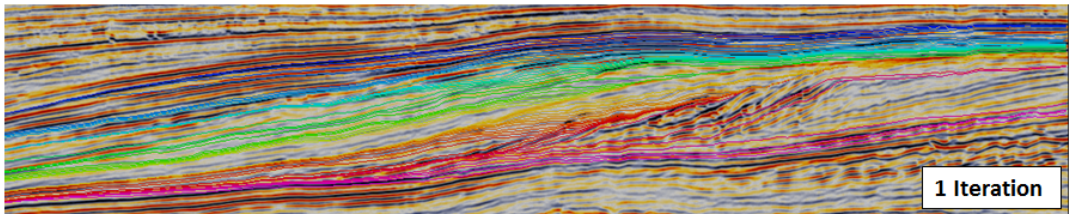

Note the gaps are filled by adding more data-driven horizon during the 2<sup>nd</sup> Iteration. Further gaps can be filled by adding one or more Iterations.

**Workflow cont'd:**

24. **Change** the active HorizonCube either by **right-clicking** the HorizonCube in the tree:

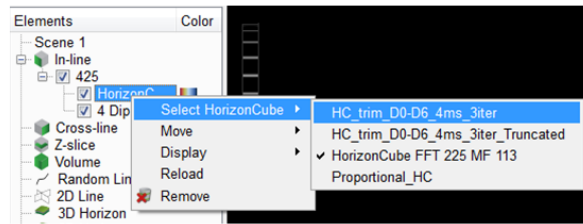

or by **selecting** it in the HorizonCube control center 

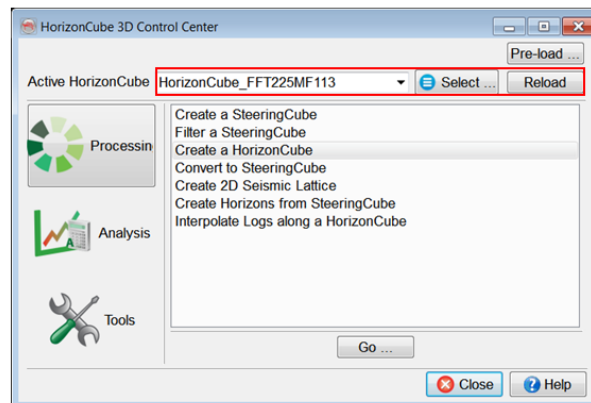

Only one HorizonCube can be active at any time in OpenTect.

## B – A Global Inversion based data-driven HorizonCube

### Exercise objective:

Create a continuous and data-driven HorizonCube based on inversion algorithm to understand the depositional history of a prograding system using principles of seismic sequence stratigraphy.

### Workflow:

1. Go to Processing > HorizonCube > 3D...
2. Select the create a HorizonCube option and click the Go.. button in the HorizonCube 3D Control Center.

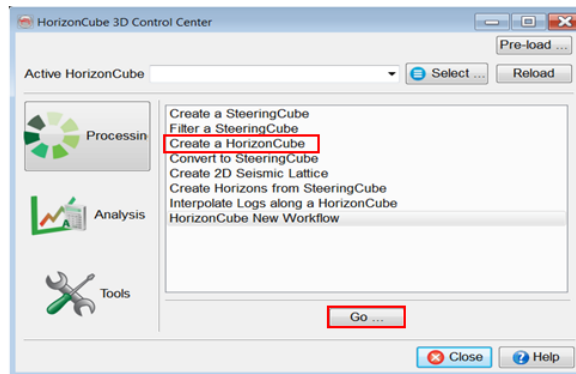
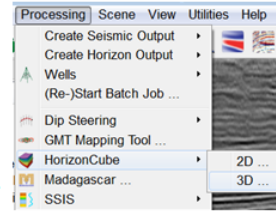

### Workflow cont'd:

3. A data-driven HorizonCube is created in a package defined by top and bottom horizons. At least two horizons are required. Select the horizons *Demo 0* → *FS4*, *Demo 4* → *Truncation* and *Demo 6* → *FS8*. Click on OK.

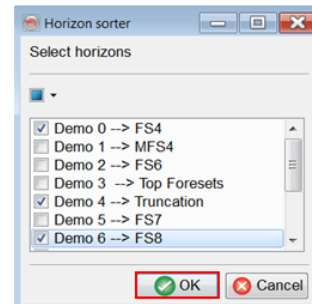

4. Optionally, Faults can be selected

In the HorizonCube creator, you choose an algorithm, settings etc.

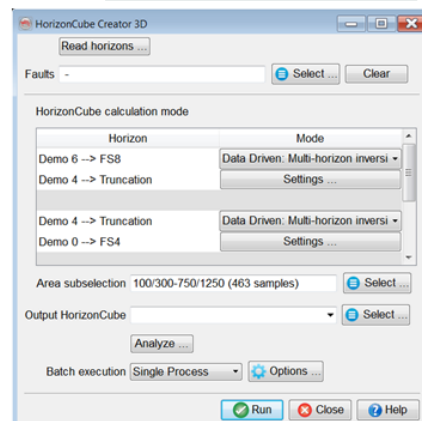

**Workflow cont'd:**

5. We will **create** a data driven HorizonCube using inversion based algorithm. *Data Driven: Multi-horizon inversion* is defined by default.
6. **Click** the Settings button for the upper most package.
7. **Set** the *Steering Data* to *PCA 111*.
8. **Click** on the *Processing Parameters*.

In each package, we will be using a same initial model (Proportional). Each proportional horizon will be updated using the defined processing parameters. **Apply to all packages** option will set the same settings to all packages.

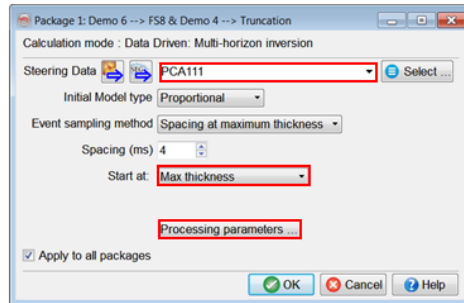
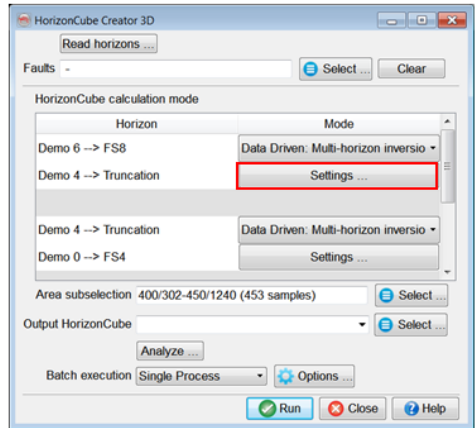

**Workflow cont'd:**

- **Fault dips** will be calculated from interpreted fault planes and merged with reflection dips from the Steering Cube if toggle is Yes.
- **Confidence weight** assigns weights to the Steering Cube. Planarity is a good confidence measure that can be calculated here, or in the Faults & Fractures plugin.
- **Confidence power** increases the contrast between planar and non-planar features.
- **Number of horizon updates** are typically between 10 or 20.
- **Number of CG solver iterations** are used to solve the gradient equations.
- **Pre-conditioning smoothing** reduces spikes in the output horizons.

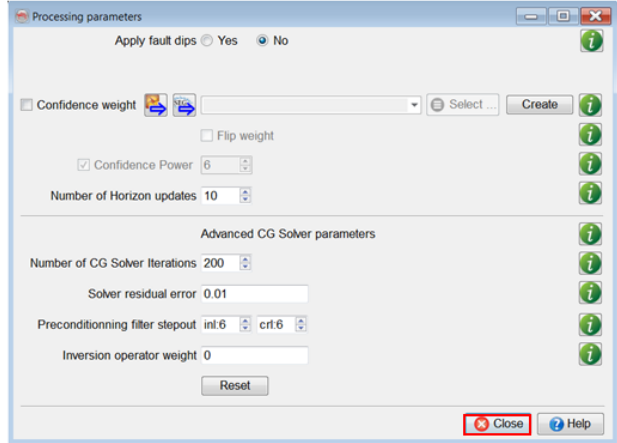

In this case stick to the defaults, hence press **Close** to continue.

CG – Conjugate Gradient



**Workflow cont'd:**

9. We will **sub-select** the processing area to 400 – 450 in-lines.
10. Provide an output name: *Inversion based HorizonCube*.
11. Press **Run** to create this HorizonCube output.

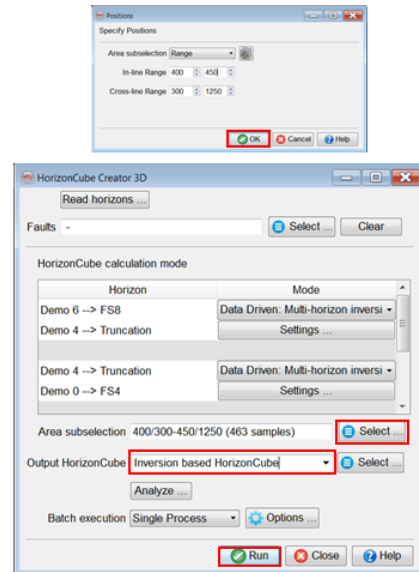
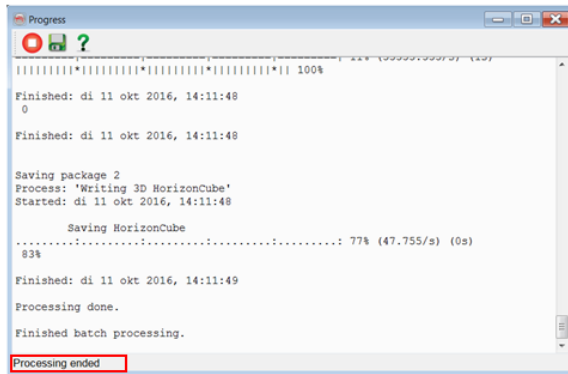

**Workflow cont'd:**

12. When processing is finished, **Add** inline 425 in the scene and **select** the attribute *4 Dip steered median filter* and **OK**.
13. **Right-click** the inline number and **select** Add > HorizonCube Display

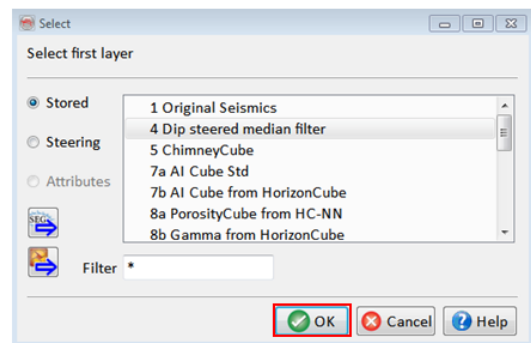
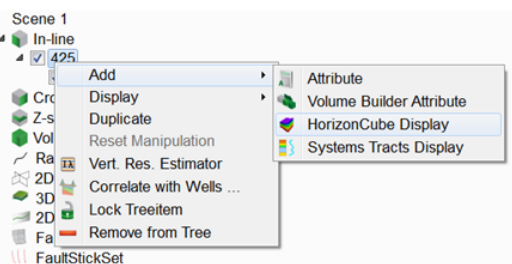
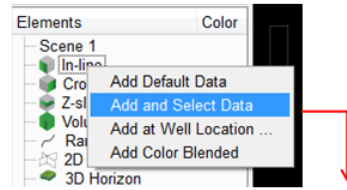

**Workflow cont'd:**

14. **Select** the *HorizonCube Inversion based HorizonCube* that is just created.

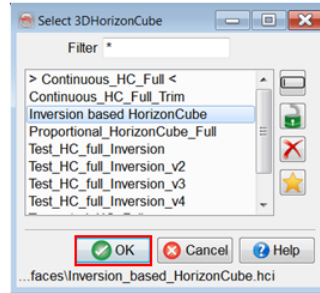

15. To explore HorizonCube display options **right-click** the HorizonCube in the tree > **Display > Properties**. **Close** the window.

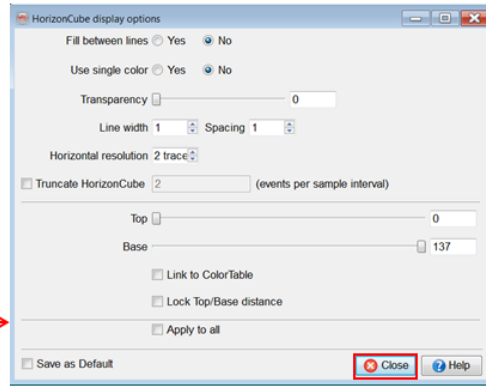
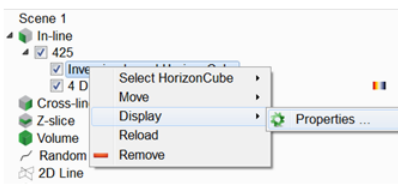

**Workflow cont'd:**

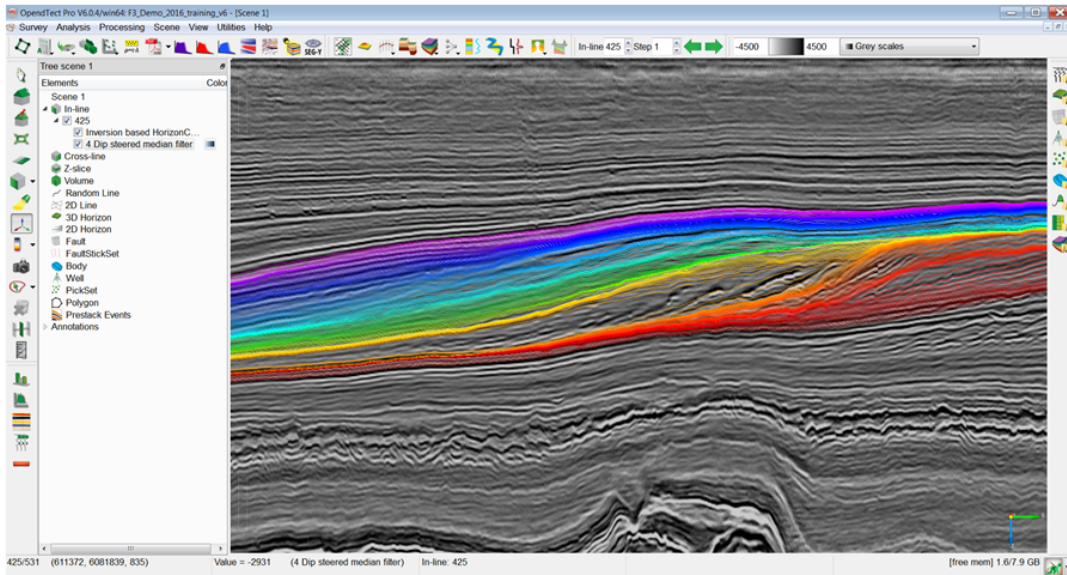

An example of this HorizonCube overlain on inline 425.

**Workflow cont'd:**

16. **Open** the HorizonCube slider.

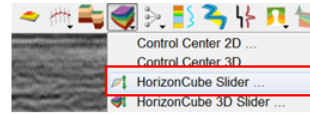

17. **Observe** and **QC** the results of your HorizonCube by using the Top and Base sliders.

The **HorizonCube slider** is a very useful tool to investigate your data and to make detailed observations of the depositional history of a sedimentary basin.

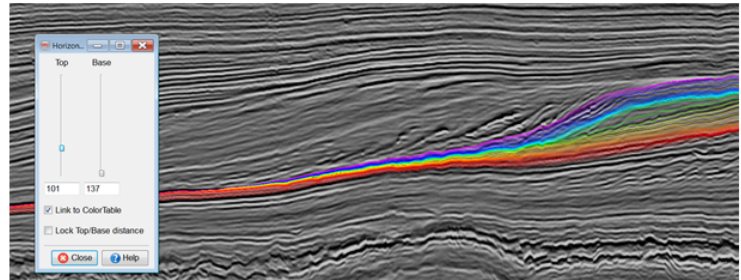

**Workflow cont'd:**

**Optional Steps (Filling the gaps):**

You may want to fill the holes by taking some events from a HorizonCube and re-computing the packages using the horizons. This workflow is presented in the following slides.

18. **Choose** the events defining a gap from this HorizonCube. Use **Top** slider to know which events are needed (e.g. events **86 & 91**).

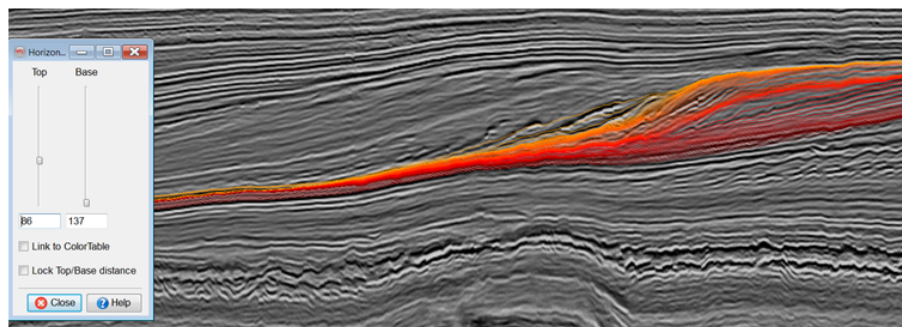

### Workflow cont'd:

19. **Open** the HorizonCube manager.
20. **Copy** the *inversion based HorizonCube* with a new name since we will be changing this one and the other one will be our backup. Once done, close the HorizonCube manager.

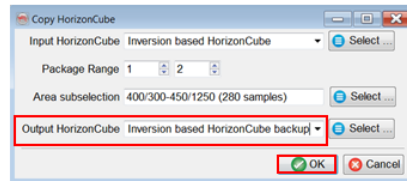
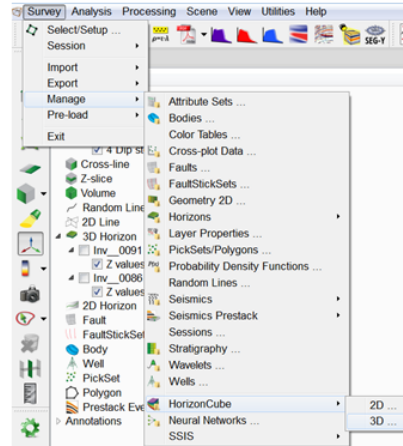
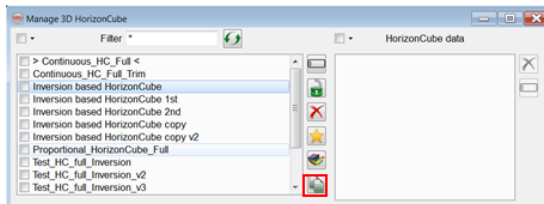

### Workflow cont'd:

21. From the HorizonCube manager, **extract** events **86 & 91** from the selected HorizonCube. 
22. The base name will be set as a prefix with an automatically generated suffix (e.g. Inv\_0086 will be a name of the output horizon). Press **OK**.
23. Once done, **close** the HorizonCube manager. At this moment, we are ready to modify an existing HorizonCube using these two horizons.

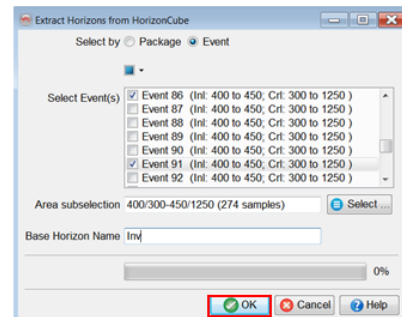

**Workflow cont'd:**

24. **Open** the HorizonCube control center.

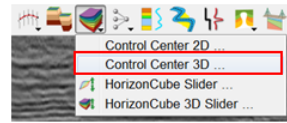

25. **Set** active HorizonCube to *Inversion based HorizonCube*.

26. **Go to** Tools and Select *Modify/Recalculate ...*

27. **Press** Go.

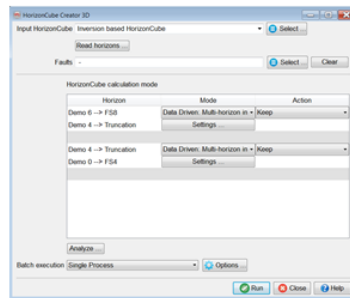
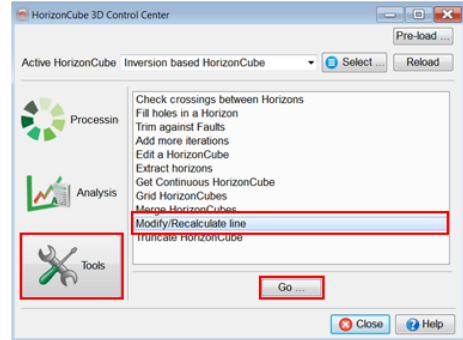

**Workflow cont'd:**

28. **Select** the HorizonCube: *Inversion based HorizonCube*.

29. **Read horizons:** (e.g.) Inv\_0086 and Inv\_0091

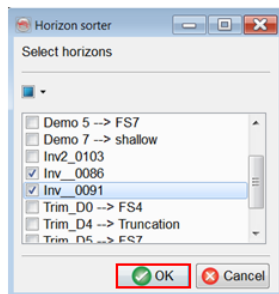
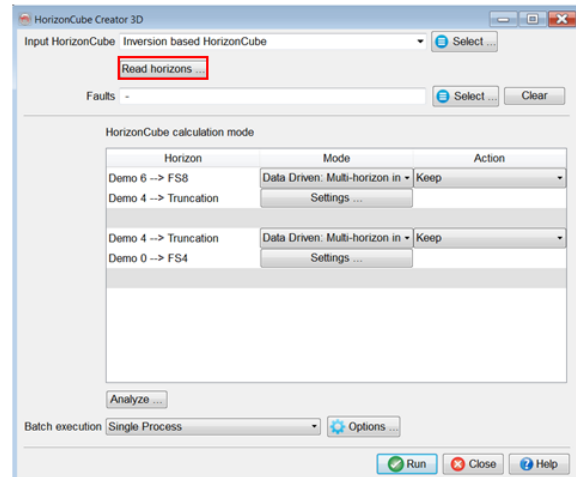

We will only select the horizons which we extracted in the previous steps.

**Workflow cont'd:**

- 30. We will choose Action **keep** for the first package and **compute** for the rest of packages.
- 31. **Ensure** that the three packages for **compute** have the **same algorithm** i.e. Data Driven: Multi-horizon inversion.
- 32. **Run**

**Optionally:** You may choose a different algorithm and settings (such as start position) for each package. It depends on the nature and data quality in a package.

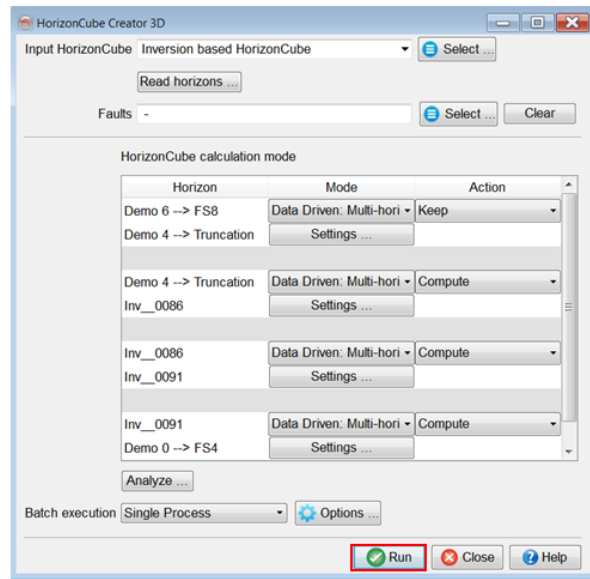

**Workflow cont'd:**

- 33. Once the processing is finished, **Reload** the HorizonCube: Inversion based HorizonCube.
- 34. The results may look like this after filling the gaps:

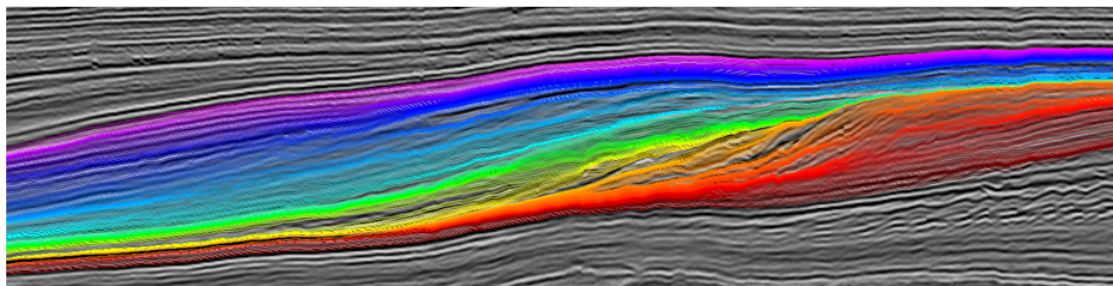
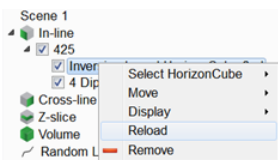

## 2.4.1b 3D Bodies From HorizonCube

Required licenses: OpendTect Pro, HorizonCube.

### Exercise Objective:

Visualize a HorizonCube in 3D by using the 3D Slider - an add-on to perform analysis in 3D along iso-timelines.

In this exercise we will investigate a prograding system in 3D by making thickness maps and geo-bodies.

### Workflow:

1. **Open** the *HorizonCube* 3D Control Center with the  icon.
2. **Select** an active HorizonCube *Continuous\_HC\_Full*.
3. **Click** the Analysis button, **Select** the 3D slider and **press** Go.

Keep the 3D slider window open. You may close the HorizonCube 3D control center window.

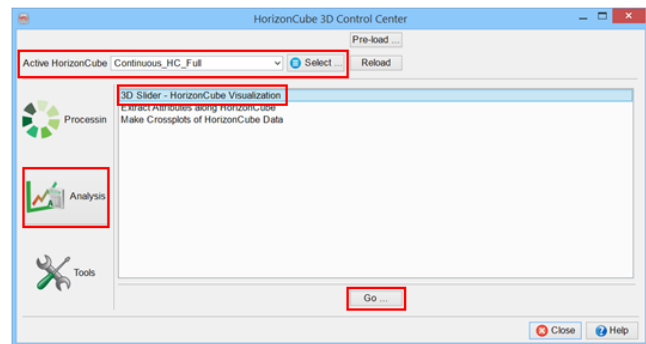

### Workflow cont'd:

4. **Add** Default data for inline 425.

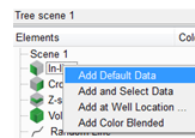

5. **Right-click** on the inline number > Add > HorizonCube Display.

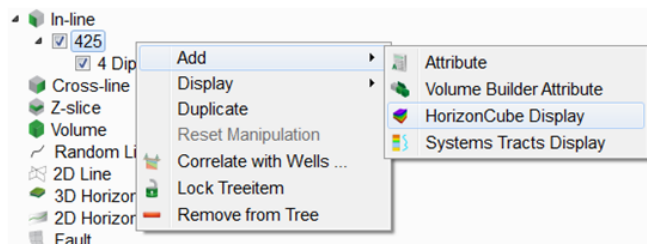

**Workflow cont'd:**

6. In the 3D slider window, **click on** Change to pre-load the HorizonCube *Continuous HC Full*.

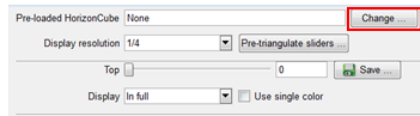

7. In the Pre-load Manager **press** Load 3D...

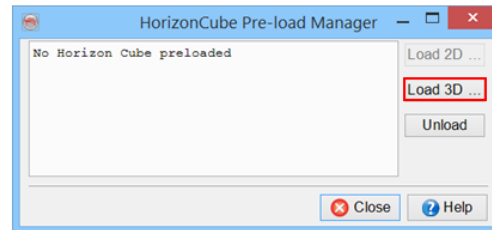

8. **Set** the Event range from 260 to 310.

9. **Press** OK and **close** the HorizonCube Pre-load Manager window.

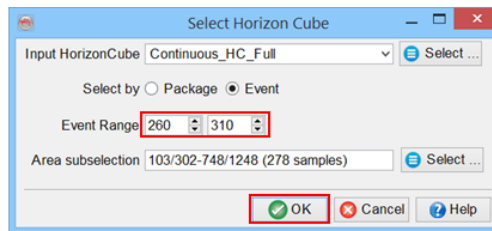

Always preload with limited range when using small RAM (under 8GB).

**Workflow cont'd:**

10. **Set** the Top horizon display: None and Base horizon display: In full.

11. **Check** Link to 2D displays option to see the HorizonCube events on the sections within the selected range.

12. **Set** Display data to Top-Base Isochron.

13. **Press** the Calculate button.

**Note:** The scene will be updated once you press the calculate button.

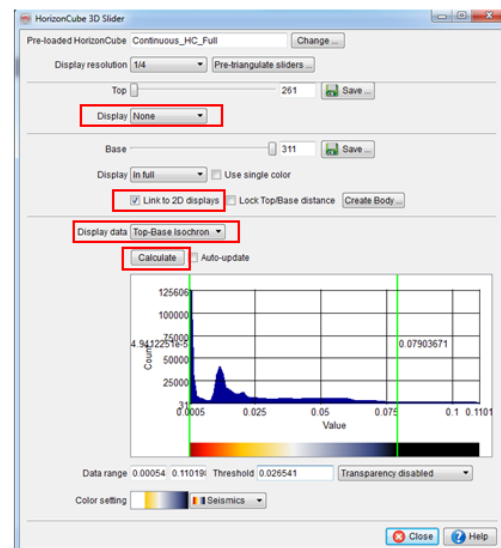



Workflow cont'd:

### Making Thickness Maps

14. **Set** the top slider to 302 (press ENTER to update) and the Base slider to 310 (press ENTER to update) and **click** Calculate.
15. The result will appear automatically in the 3D scene on the base horizon after clicking Calculate.

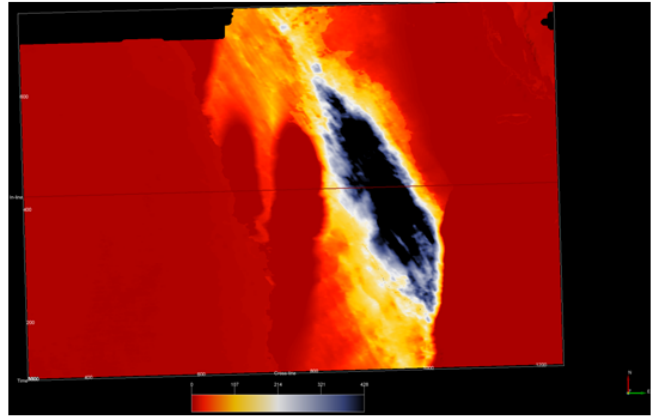

Example isochron map between events 302 and 310

Workflow cont'd:

16. **Repeat** the exercise for the following horizon pairs and observe the shifts in the depositional center. **Press** Enter and **Calculate** every time after updating the numbers for the Top and Base sliders.

Top: 285, Base 302

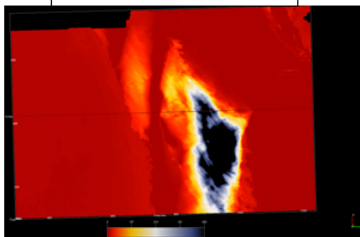

Top: 275, Base 285

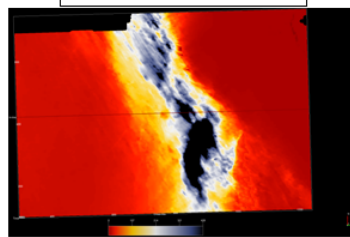

Top: 265, Base 275

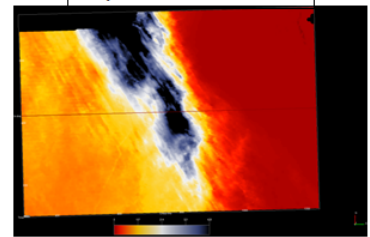

**Workflow cont'd:**

**Extracting Geobodies**

17. For this exercise we will apply a transparency threshold for all thinner regions below the cut-off to preserve and outline of a thicker region.

18. At the bottom of the 3D slider, **specify** Threshold = 0.02 (**Press Enter**) and **set** the transparency to Transparent below threshold. (In the histogram, a thin vertical red line will appear, which corresponds to transparency).

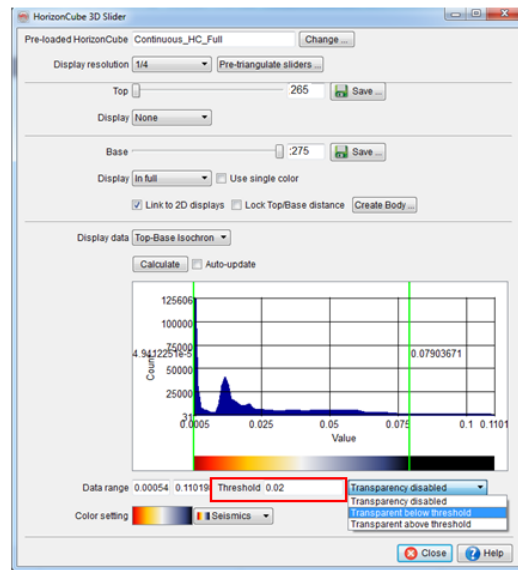

**Workflow cont'd:**

**Extracting Geobodies**

19. **Press** the Create Body button.

20. **Set** mode to Automatic filling, the threshold value will remain unchanged.

21. **Set** the Body value option to Above threshold. **Click** Run.

22. **Close** 3D Slider.

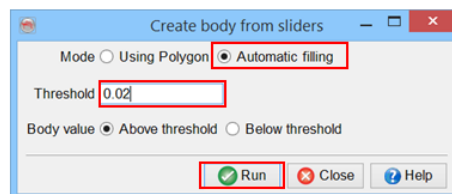
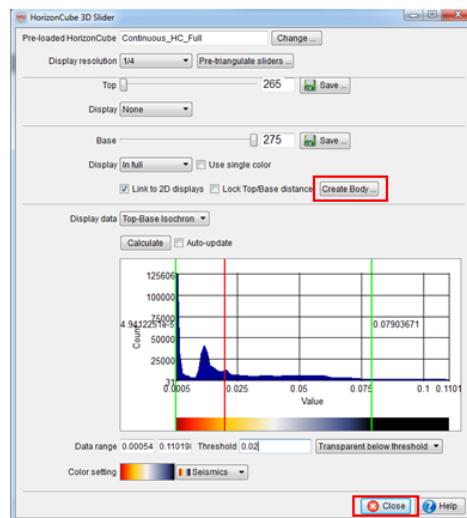

---

## Workflow cont'd:

### Extracting Geobodies

23. The body will appear in the scene. If you are satisfied with the geobody you may save it to disk by right-clicking on the <New Body > in the tree > Save as..

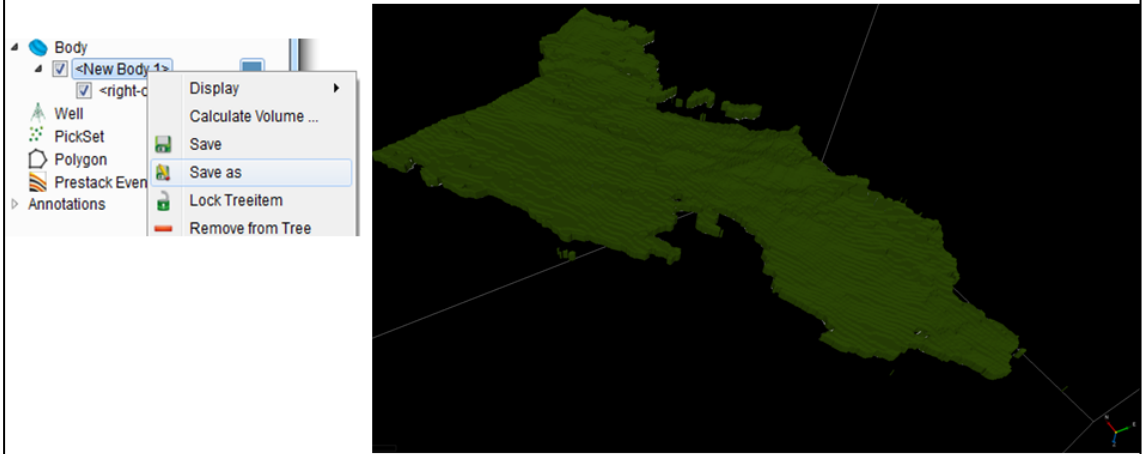

## 2.4.1c Truncate HorizonCube

Required licenses: OpendTect Pro, HorizonCube.

### Exercise Objective:

Truncate a HorizonCube to prepare Wheeler diagrams and perform seismic sequence stratigraphic interpretation.

1. **Open** the HorizonCube 3D Control Center with the  icon.

2. **Select** the Truncate HorizonCube option from the Tools menu and **click** Go...

There are two types of HorizonCubes: continuous and truncated

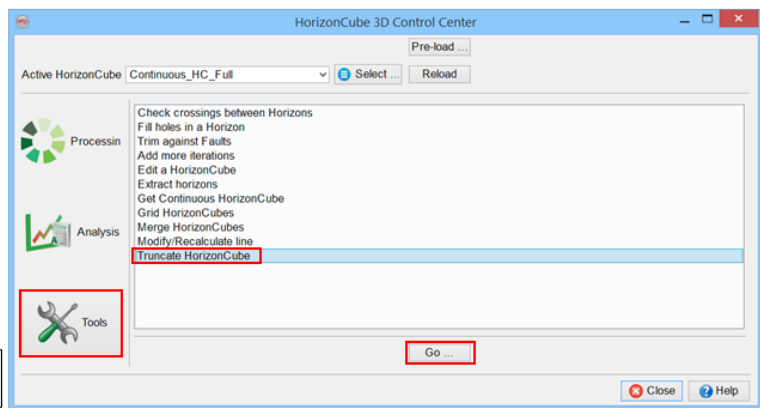

### Workflow cont'd:

3. **Select** *HorizonCube FFT 225 MF 113* (created in previous exercise) as Input HorizonCube.
4. Leave the area sub-selection and minimum spacing as default.
5. **Give** an appropriate name, e.g. *HorizonCube FFT 225 MF 113\_truncated*, and **press** OK.

Tip: If the truncated HorizonCube includes too much irrelevant events (noise), go back and increase the *Maximum density*

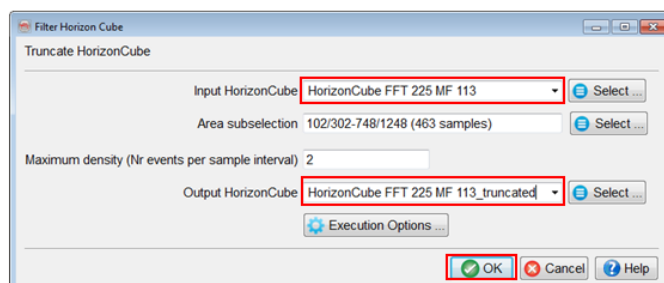

**Workflow cont'd:**

6. Batch processing window will pop up.
7. **Leave** the process running until you **read** the message: Finished batch processing.

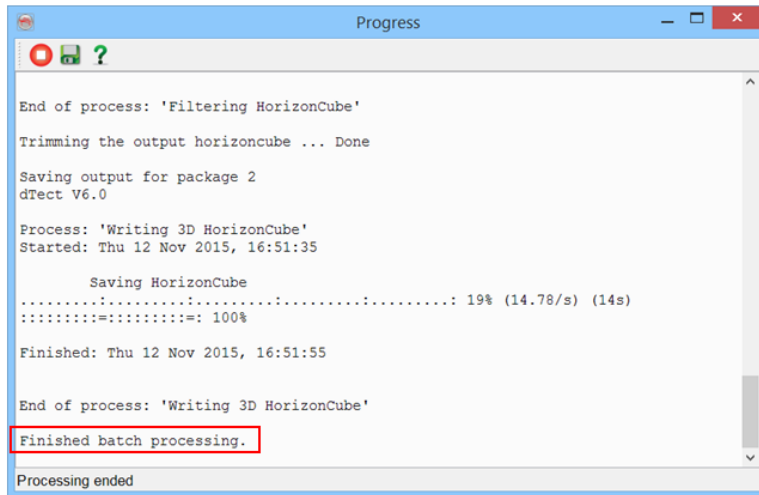

**Workflow cont'd:**

8. After processing, **switch** to the truncated HorizonCube via HorizonCube 3D Control Center  by **selecting** *HorizonCube FFT 225 MF 113\_truncated*.
9. **Close** HorizonCube 3D Control Center.

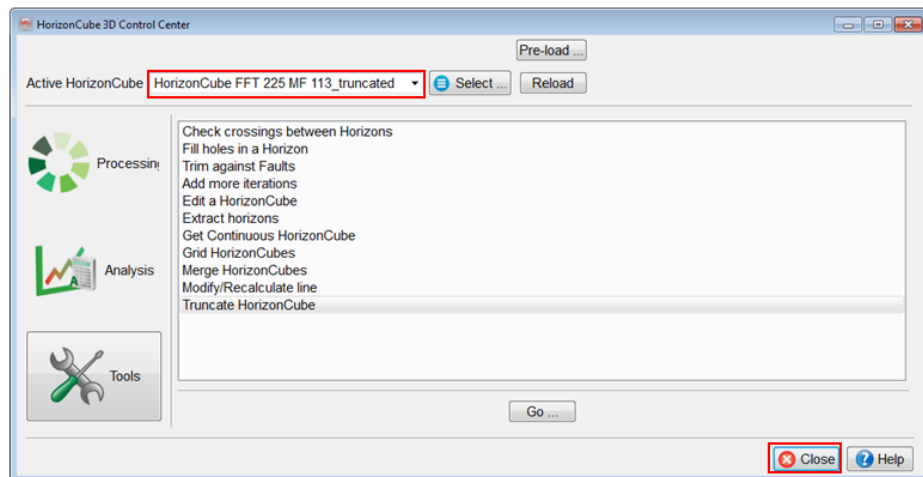

**Workflow cont'd:**

10. **Right-click** on In-line in the tree > Add Default Data.

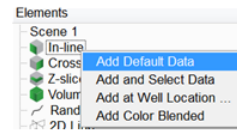

11. **Right-click** on the inline 425 > Add > HorizonCube Display, to display the truncated HorizonCube in the scene.

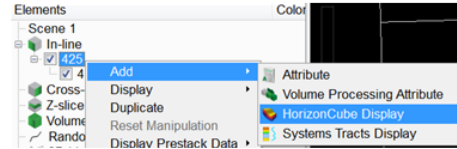

12. Switch back to the continuous HorizonCube by **right-clicking** on HorizonCube name > Select HorizonCube, to compare the two results.

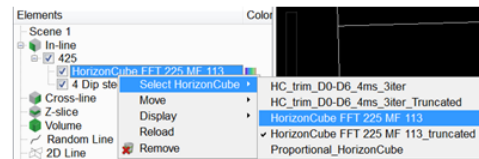

The results should be similar to the ones shown below

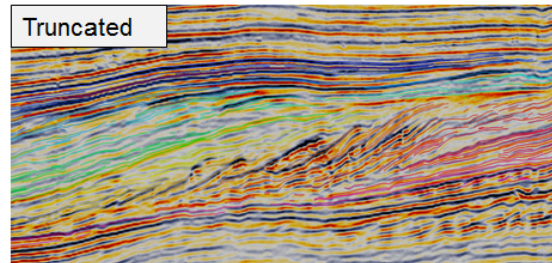
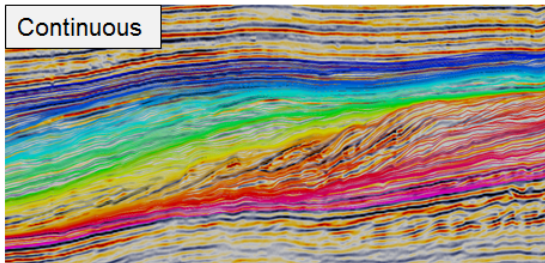

## 2.4.1d Horizons From HorizonCube

Required licenses: OpendTect Pro, HorizonCube.

### Exercise Objective:

Extract multiple horizons from a HorizonCube.

### Workflow:

1. **Add** the default data by clicking *inline* in the tree. Next, **add** a HorizonCube overlay. Select the active HorizonCube *Continuous\_HC\_Full* if prompted.
2. **Open** the *HorizonCube* 3D Control Center with the  icon.
3. **Select** Extract Horizons under the *tools* menu and **click** Go ...

The active HorizonCube is automatically displayed

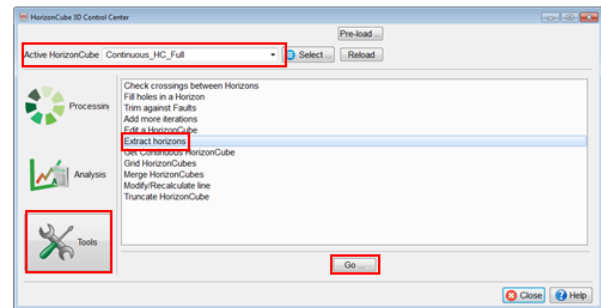
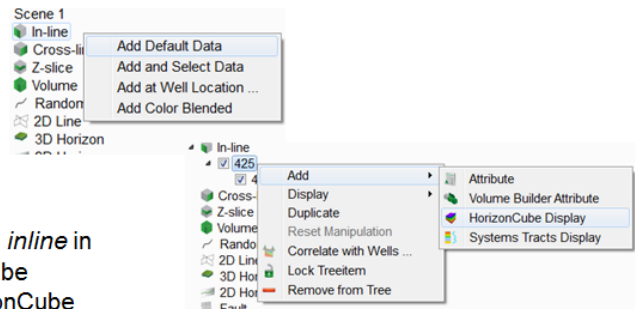

### Workflow cont'd:

4. **Scroll** up and down using the slider, while **observing** the HorizonCube events in the scene.
5. When you locate a horizon you wish to extract, **click** on Pick Horizon. A separate pop-up window will appear.
6. **Give** an appropriate output name and **click** OK.

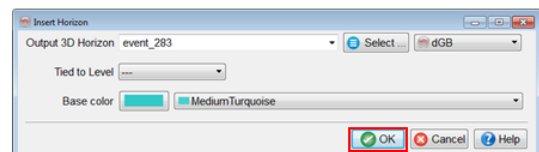
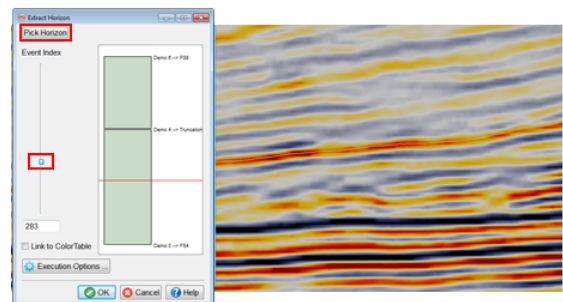

**Workflow cont'd:**

7. **Repeat** the exercise a few times for the events you wish to extract. Then **click OK**.

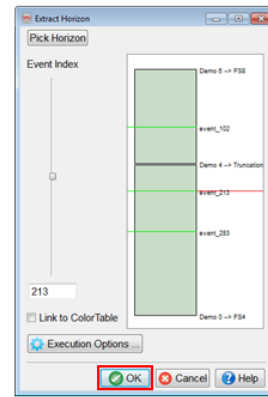

Picked horizons in the slider

8. A separate *batch processing* window will **open**. After the processing is done, the extracted horizons can be **loaded** via *horizons 3D > Load...* in the tree.

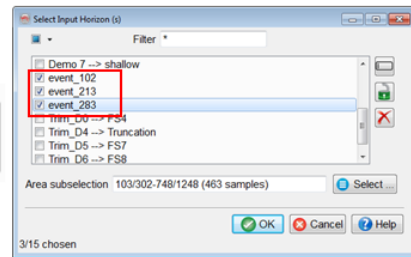
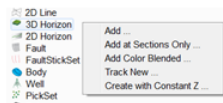



## 2.4.2a Stratal Terminations

Required licenses: OpendTect Pro, SSIS.

### Exercise objective:

Annotate stratal terminations and lap-out patterns using standard **Arrows**.

### Workflow:

1. **Add** inline 425 using default data.
2. **Expand** the Annotations item.
3. **Click** on Arrows and **select** New Arrows Group...
4. Name the arrow group to *Stratal Termination* and press **OK** to add this to the tree.

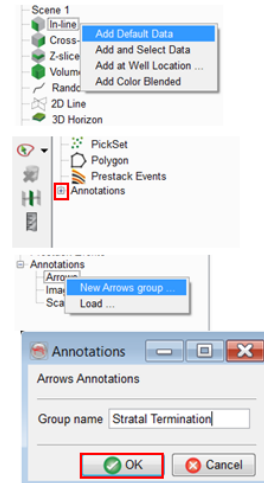

OpendTect annotation (arrows, images, and scale) are handy tools to highlight and describe features of interest. In seismic sequence stratigraphic interpretation arrows are used traditionally to map lapout patterns and truncations.

### Workflow cont'd:

5. *Stratal Termination* element should be active in the tree (a click on the name activates the item). Switch to the right mode .
6. Now you **pick** on the seismic inline at positions where you want to insert an arrow. First click adds an arrow head. Rotate and click one more time to pin it.

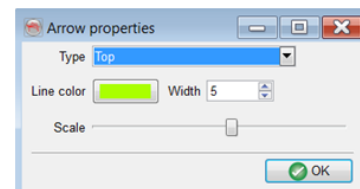
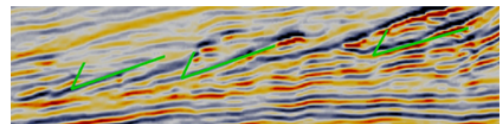

- Ctrl + Click on the arrow to delete it.
- Change the type, color, width and size of the arrow via right-click on *Tree > Annotations > Arrows > Stratal Terminations > Properties...*

**Workflow cont'd:**

7. Continue the interpretation on this line.

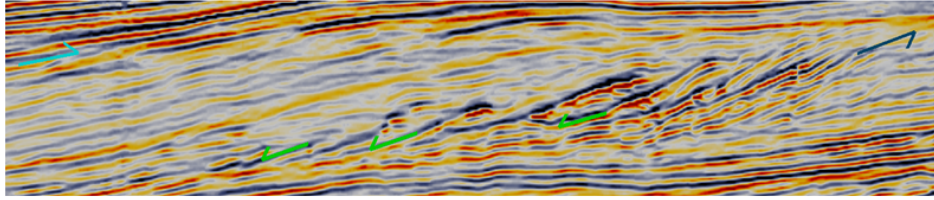

8. **Right-click** on *Stratal Termination* and **Save**.

Optionally make different arrow groups:

- Downlaps.
- Onlaps.
- Truncations.

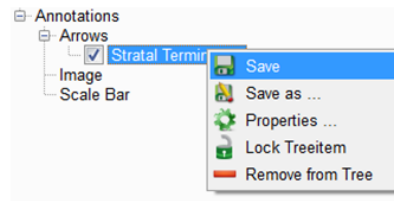

## 2.4.2b Stacking Patterns

Required licenses: OpendTect.

### Exercise objective:

Evaluate stratal stacking patterns using the HorizonCube slider.

### Workflow:

1. **Add inline** with default data (if the line exists, skip this step).
2. **Add** HorizonCube overlay on inline 425.
3. If no HorizonCube is selected, it will ask you to select a HorizonCube. You will choose *Continuous\_HC\_Full*.

Common stacking patterns are:

- Aggradation
- Progradation
- Retrogradation
- and combination of these.

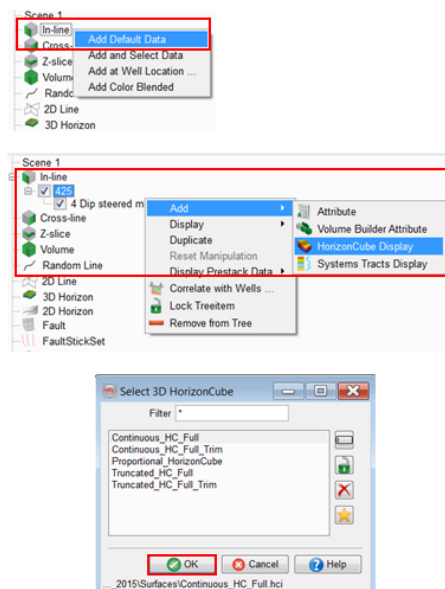

### Workflow cont'd:

4. **Launch** the HorizonCube slider.
5. **Play with the sliders** by moving the Top Slider & observe changes in the scene.

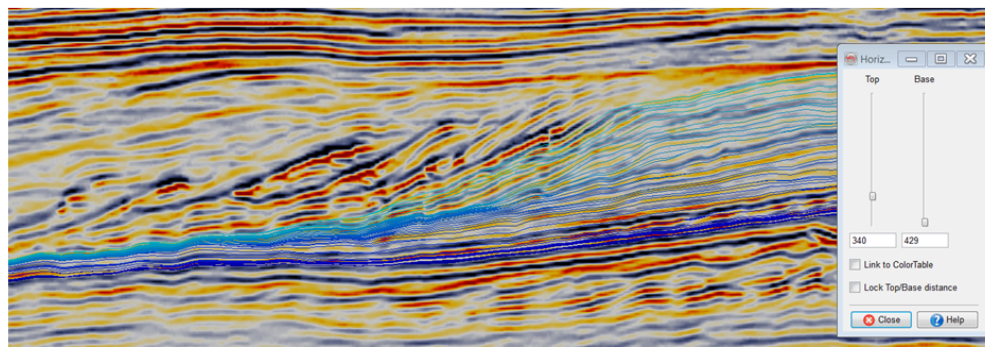
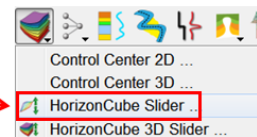

**Workflow cont'd:**

6. For better color contrast, you may want to **change the color scale** of the background image to *Greyscale*. See the steps below:

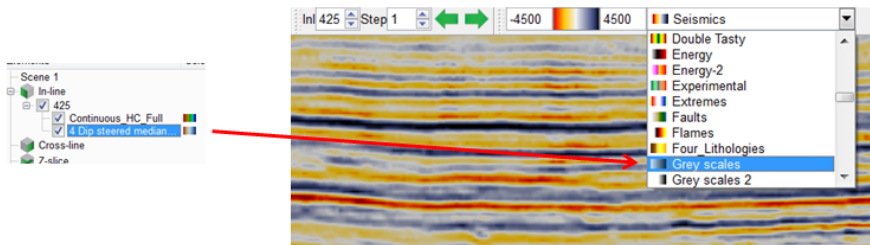

**Workflow cont'd:**

7. (a) An example illustration of making observations:

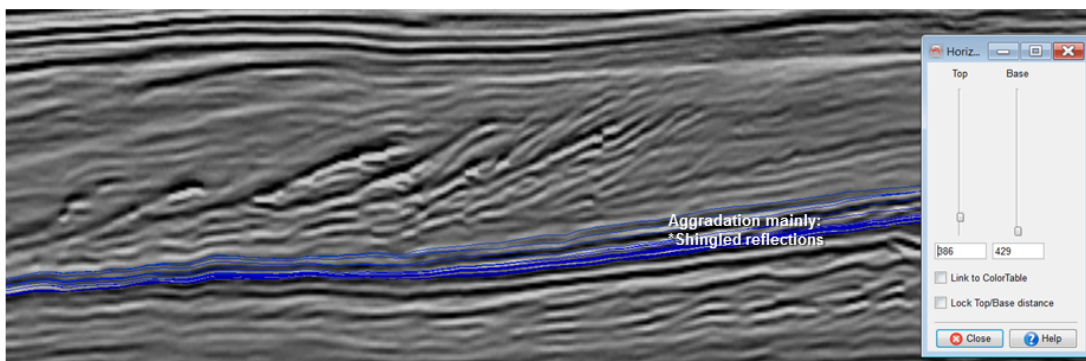

\* You have also learnt about this zone while doing spectral decomposition (RGB Blending) & waveform segmentation.

**Workflow cont'd:**

7. (b) An example illustration of making observations:

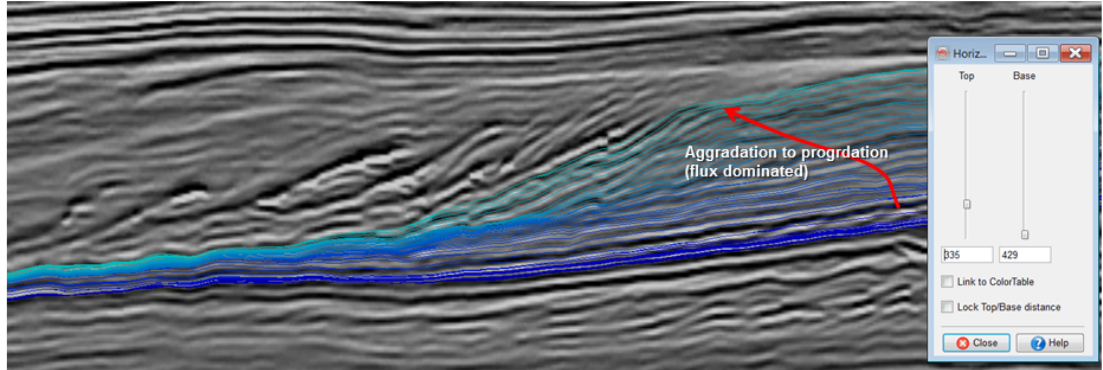

**Workflow cont'd:**

7. (c) An example illustration of making observations:

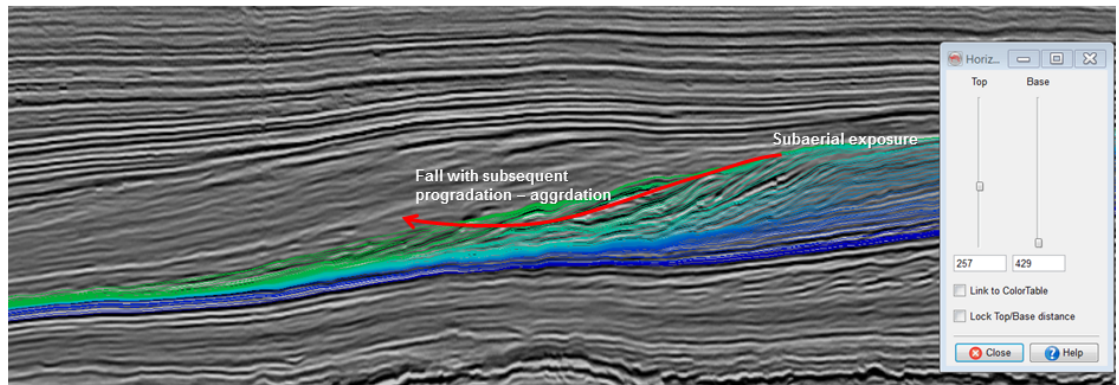

**Note:** The scene is a bit zoomed out.

## 2.4.2c Wheeler Scene

Required licenses: OpendTect Pro, SSIS.

### Exercise objective:

Wheeler transform (flatten) seismic data and co-render the flattened seismic with the flattened horizons of a truncated HorizonCube.

### Basic concept of Wheeler diagrams (Flat horizons)

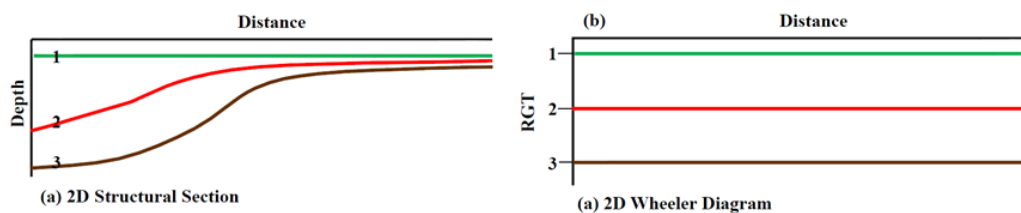

Structural domain horizons / surfaces are representative of relative geologic time (from P.R. Vail)

RGT – Relative Geologic Time

### Workflow cont'd:

1. **Add** Scenes > New [Wheeler].

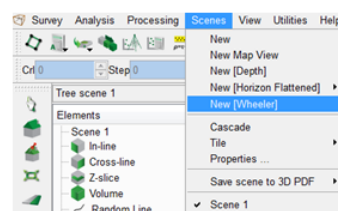

2. If no HorizonCube is active, it will ask to select a HorizonCube, **Select** *Continuous\_HC\_Full*. Otherwise, it will use the active HorizonCube to create a new Wheeler scene.

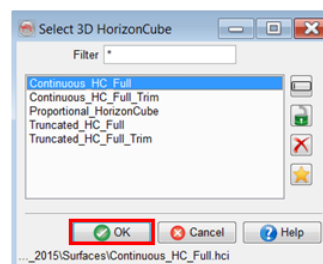
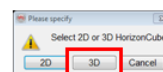

**Workflow cont'd:**

It will launch a new empty scene with a special **Tree Scene 2** attached to it.

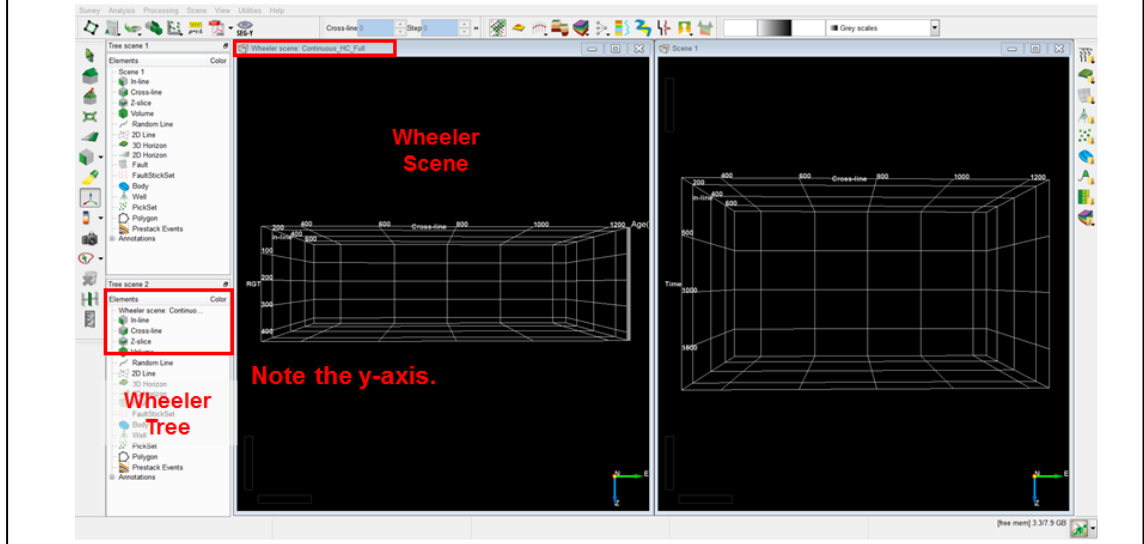

**Workflow cont'd:**

3. **Add a default data** in both the normal and Wheeler scenes.
4. **Add a HorizonCube** on inline 425.

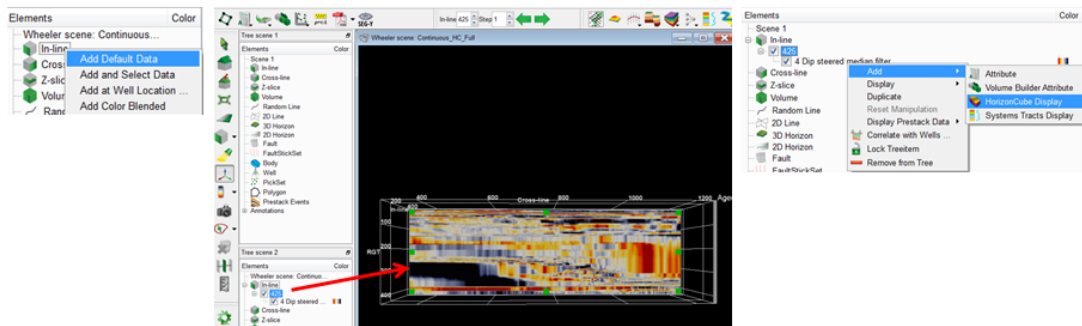

## Workflow cont'd:

Your display may look like as shown below. Note that viewing a continuous HorizonCube in Wheeler scene is not interesting. You may want to truncate it to remove all convergence patterns (next slide).

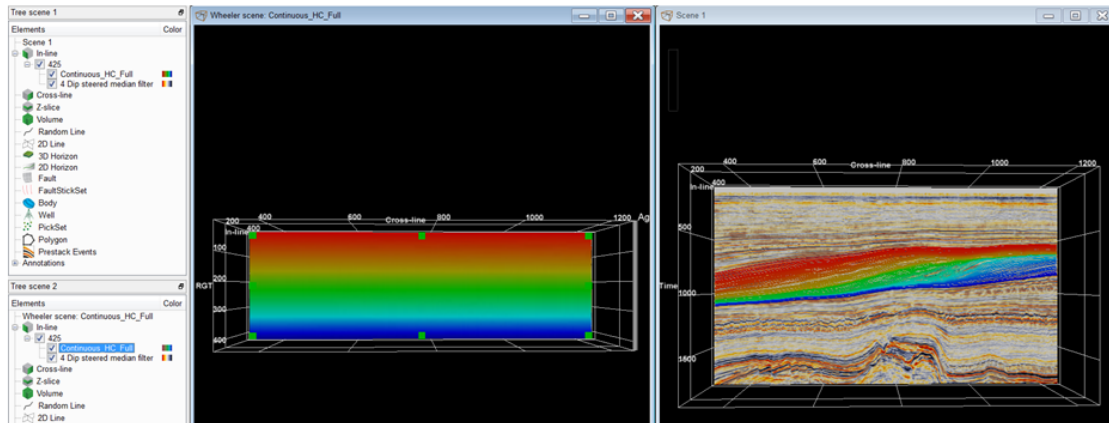

## Workflow cont'd:

5. **Make** a truncated HorizonCube display (on-the-fly) using HorizonCube display properties dialog.
6. **Check Truncate HorizonCube**, click next to 2 and press **Enter** from the keyboard.
7. **Apply to all** to apply the same HorizonCube settings to all displays. When you will close the dialog, it will apply the same settings to all other scenes.

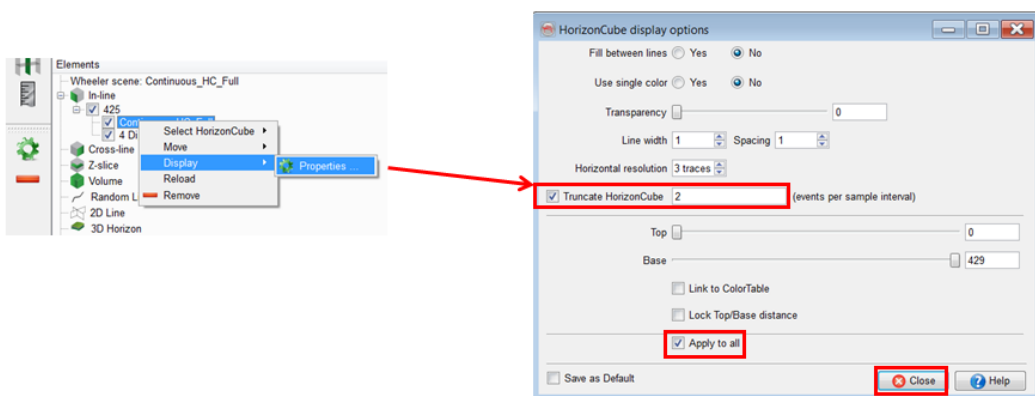



**Workflow cont'd:**

Adjust the display:



8. **Make** an inline view.

9. **Tile** the scenes.

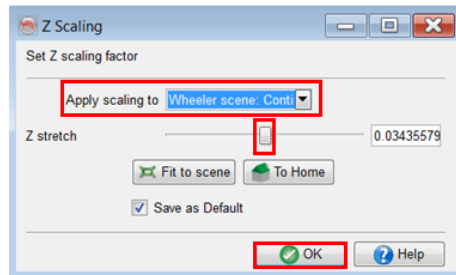
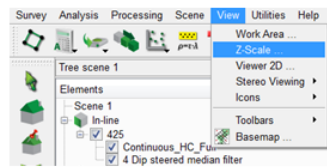
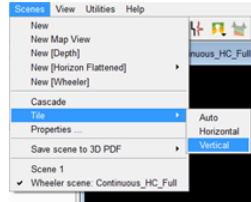
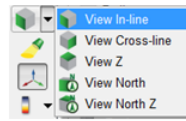
10. **Change the z-scale** of the Wheeler to adjust the display according to your view.



**Workflow cont'd:**

11. **Change** the perspective  view to the orthographic  view.

12. **Adjust** the scene by co-visualizing both views. You may also need to zoom in.

**Tip:** Avoid rotating a scene. Just use:

- pan (mouse wheel pressed or Ctrl+left mouse button pressed)
- zoom (spin mouse wheel or Ctrl+Shift+Left mouse button pressed).

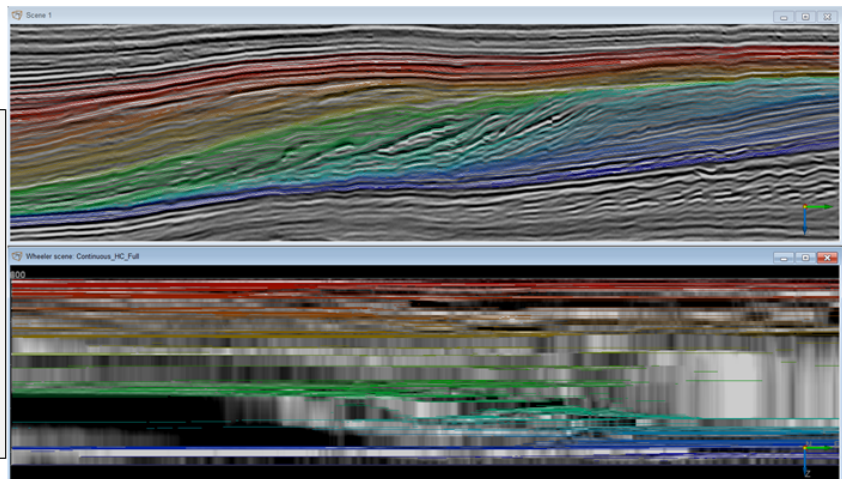

**Workflow cont'd:**

13. Use the **HorizonCube slider** to slide the events up and down. Now you are ready to perform sequence stratigraphic interpretation.

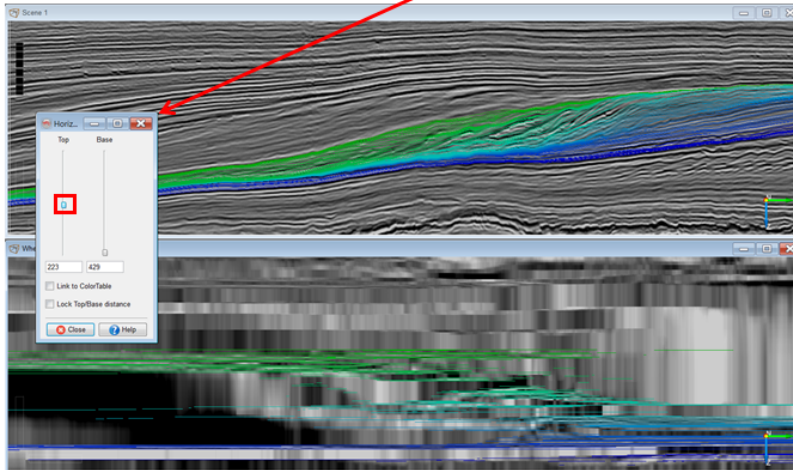
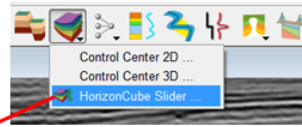

---

## 2.4.2d Systems Tracts

Required licenses: OpendTect Pro, SSIS.

**Exercise objective:**

Perform systems tracts interpretation with the SSIS plugin.

**This exercise assumes that you are familiar with sequence stratigraphy and the followings:**

- Transgression & transgressive systems tract (TST)
- Normal Regression & highstand or lowstand systems tract (HST/LST)
- Forced Regression & falling stage systems tract (FSST)

### Sequence Stratigraphic Models in OpendTect:

Each model has its own *name*, *color code*, *base-level phase*, *Top surface name*, *top surface color*.

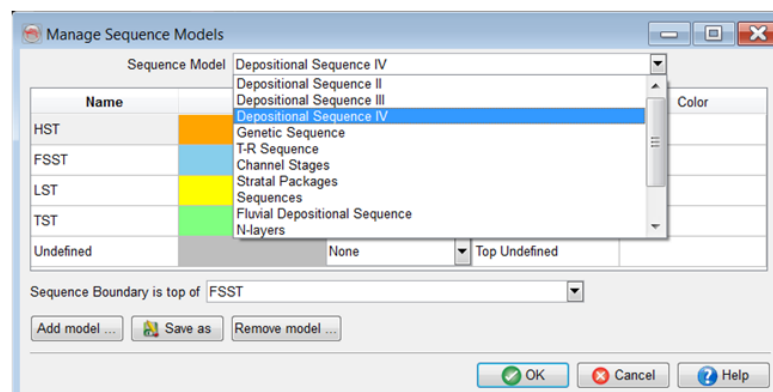

You can also make your own model if you press the **Add model** button.

**Workflow:**

1. **Add inline 425** (if it does not exist).

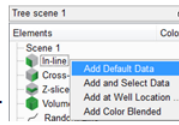

2. **(Optional)** In Exercise 2.4.2a, you made some **annotations (arrows)** on inline 425. You may want to display them in the scene to begin with SSIS interpretation.

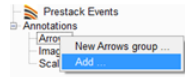

Following this, select the ones that you saved earlier on.

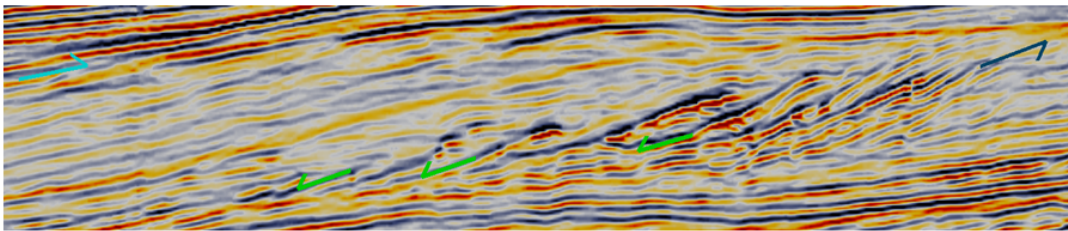

**Workflow cont'd:**

**Tip:** If you intend to study depositional shifts, we recommend selection of a truncated HorizonCube (which is already pre-processed).

3. **Activate** a truncated HorizonCube (Truncated\_HC\_Full).

- Launch the 3D HorizonCube control center. 
- Select the active HorizonCube.

4. **Add the HorizonCube** display on inline 425.

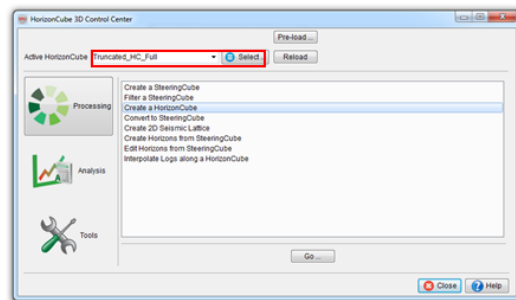
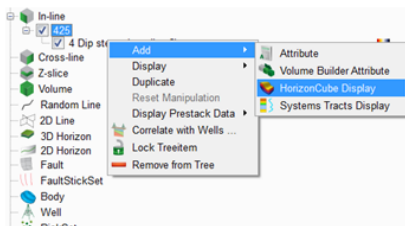

**Workflow cont'd:**

5. If you do not have any Wheeler scene display, **Add a Wheeler Scene\*** (Scene > New Wheeler ..) .
6. **Add inline 425** with default data for the Wheeler tree/scene.
7. **Add HorizonCube** display.

There are two ways of performing SSIS interpretation:

- Stacking patterns in a normal (structural) scene.
- Or co-visualizing both the normal and Wheeler scenes.
- In this exercise, we will co-visualize both scenes.

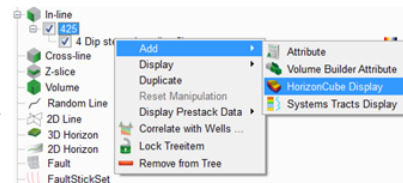
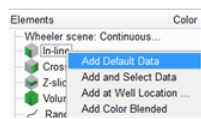
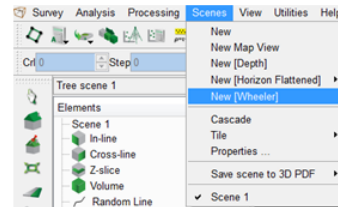

\* See Exercise 2.4.2c

**Workflow cont'd:**

8. **Open** the SSIS interpretation window by clicking on this icon. An interpretation window will open, with the familiar HorizonCube sliders on the left side; interpretation column, base level curve, and timeline in the white pane on the right.

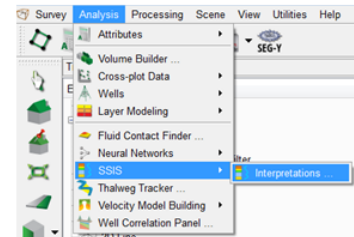

**HorizonCube Slider**

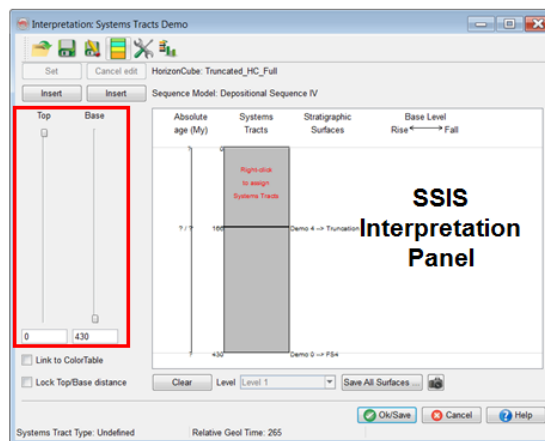

**Workflow cont'd:**

9. **Open** the Sequence Models selection window by pressing: 
  - View the options of the sequence models available. For this exercise, the default model (Depositional Sequence IV) will be used.
  - Close this window when you have finished viewing the options.
  
10. To begin your interpretation, you will use the HorizonCube sliders:
  - Slide the **top slider** all the way to the bottom while co-visualizing the Wheeler and normal scenes.
  - Slowly drag the **top slider** up until you find a breaking point that would indicate a different system tract.

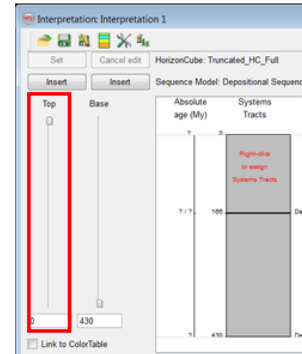

**Workflow cont'd:**

**Tip:** You may want to tile the scenes vertically.

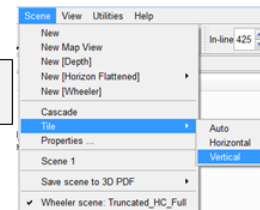

11. Position the **top slider** where you intend to insert a boundary.

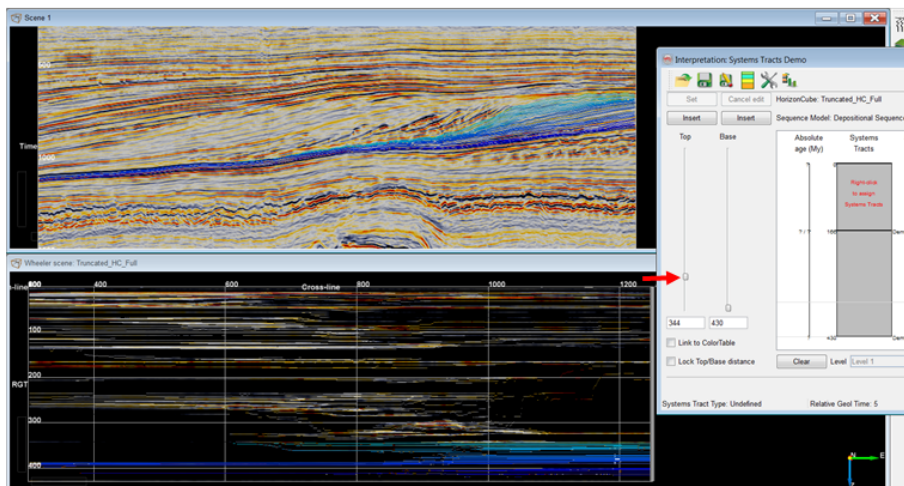

**Workflow cont'd:**

- 12. Press the insert** button which lies just above the top slider. This will insert a boundary in the stratigraphic column.

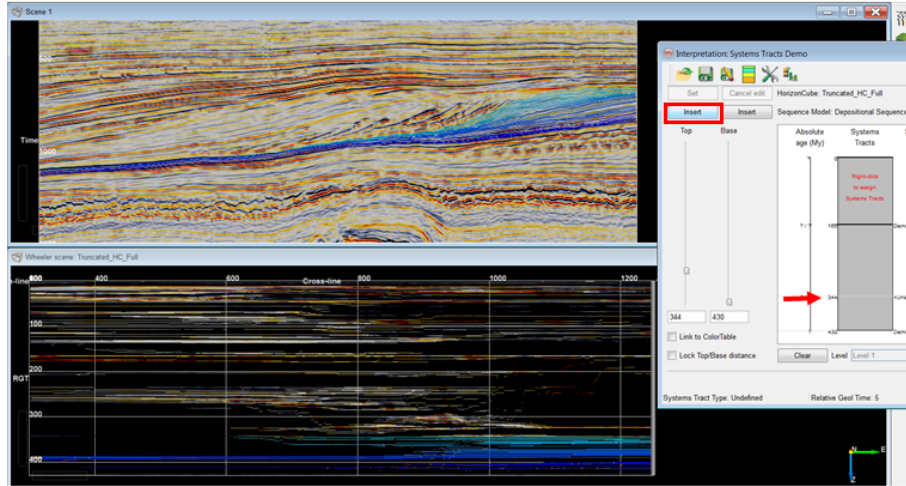

**Workflow cont'd:**

- 13. Right-click** in the middle of the package that you added and assign the systems tract.

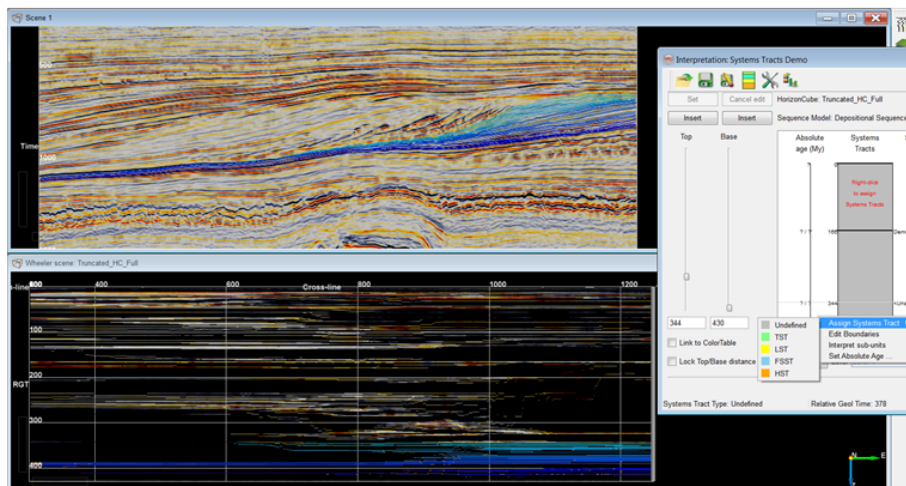

**Workflow cont'd:**

14. The selected systems tract will be assigned.

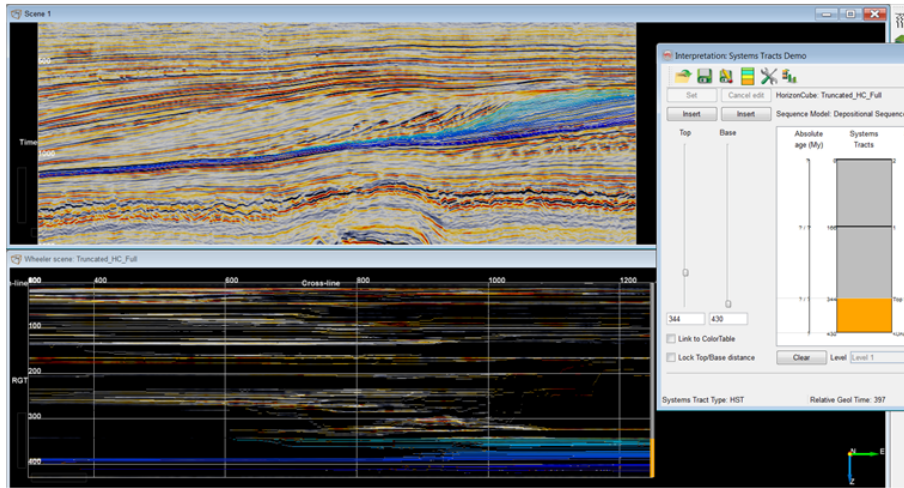

**Workflow cont'd:**

15. By repeating these steps, the entire stratigraphic column can be interpreted and systems tracts are assigned.

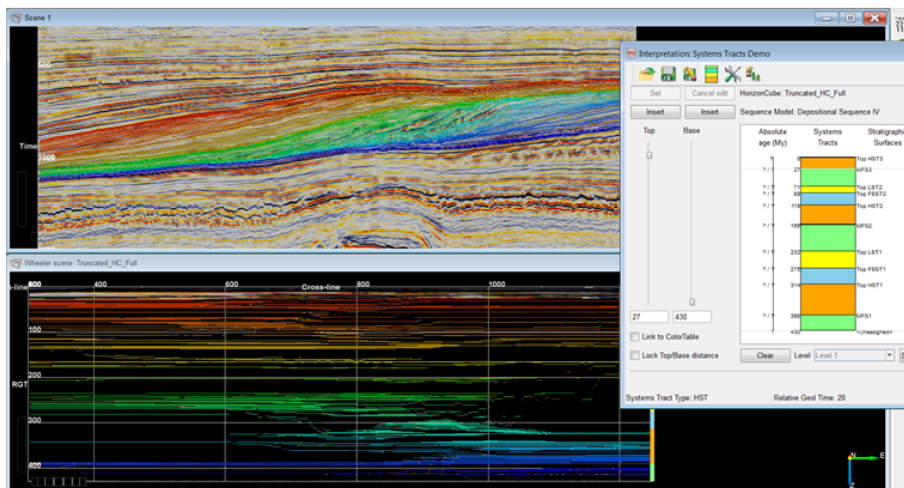



**Workflow cont'd:**

16. You may want to **overlay** the inline with the interpreted **Systems tract** in both scenes.

17. Once done, you may want to **Save**  this interpretation.

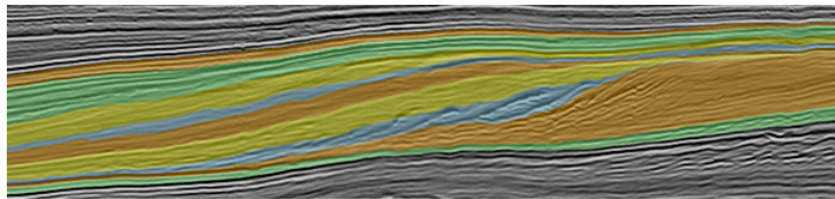
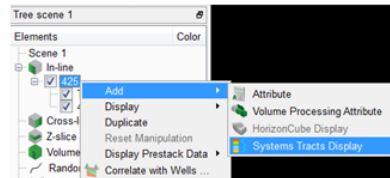

You can save  more than one interpretation per HorizonCube.

## 2.4.2e Statistical (Thickness) Curves

Required licenses: *OpenText Pro, SSIS.*

### Exercise objective:

Extract statistical (thickness) curves to express data-driven nature of base-level variations.

**This exercise requires an existing SSIS interpretation and an active\* HorizonCube.**

In Exercise 2.4.2d, you made some **SSIS interpretation**. You may want to use them as a reference interpretation to extract statistical curves.

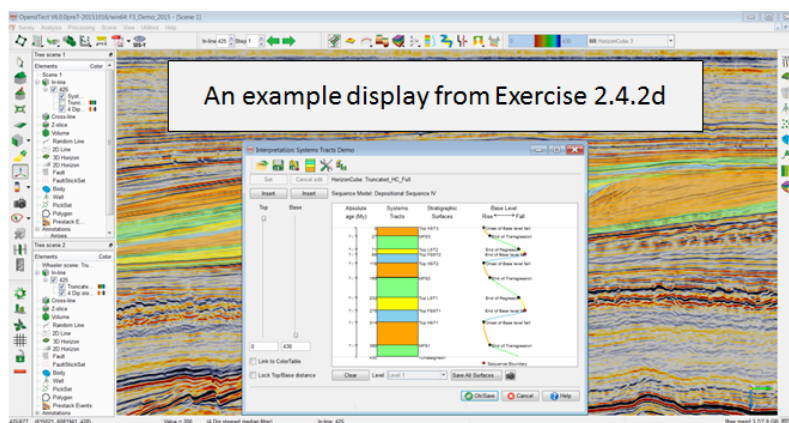

\* Processing > HorizonCube > 3D >....

### Workflow:

1. In the SSIS window, **launch** the statistical curve extraction dialog:



#### Tips on area sub-selection:

1. Try to plot the thickness variations at a given depocenter vs. coastal regions per systems tract
2. Compare the two curves by taking snapshots. 

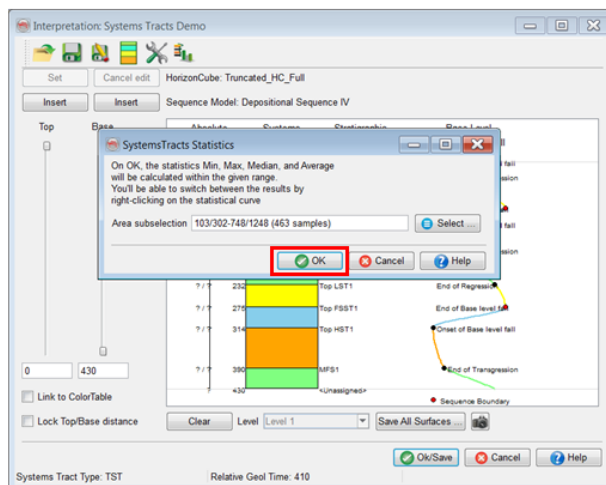

**Workflow cont'd:**

2. If you proceed further, it will start extracting data within the sub-selected area and perform statistics.

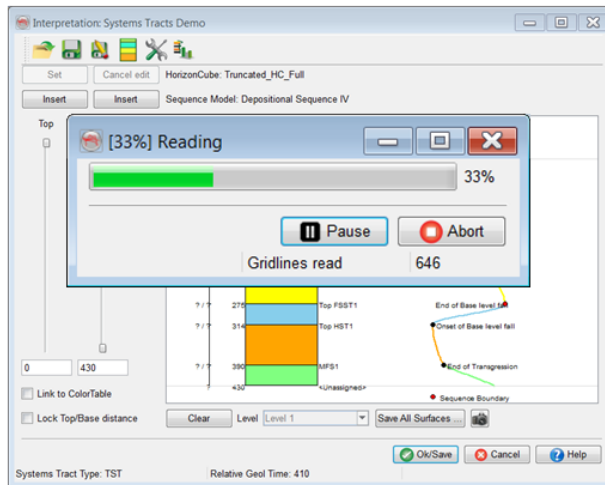

**Workflow cont'd:**

3. Once the processing is finished, an Average Thickness curve will appear in red.

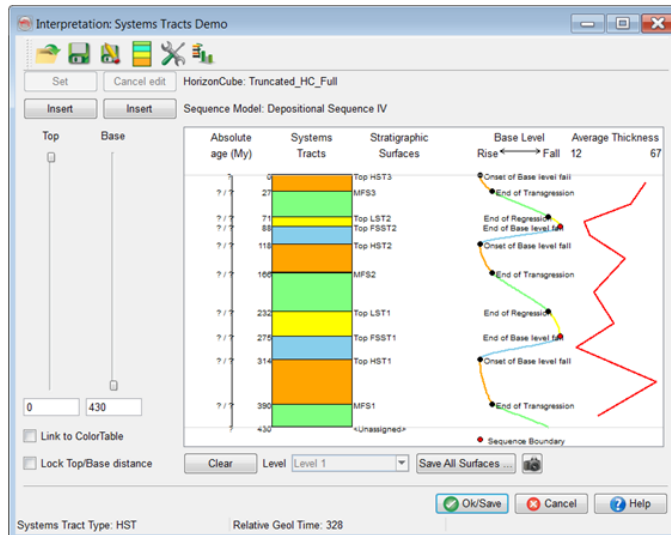

**Workflow cont'd:**

4. You may want to change the statistics and plot a different curve. To do that, just **right-click on the curve** and choose other stats.

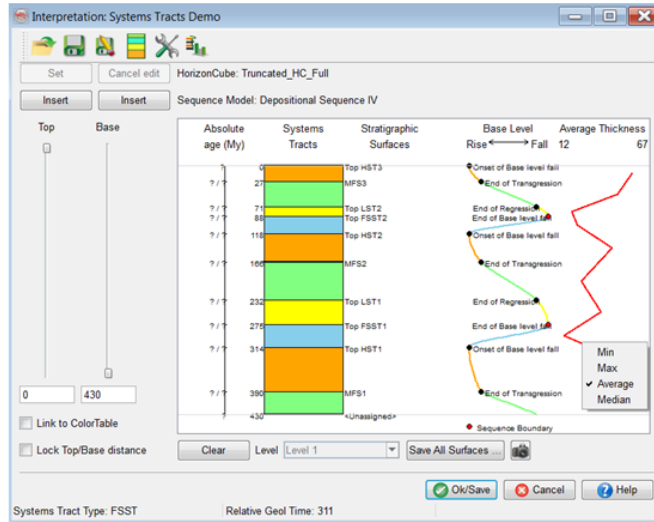

## 2.4.2f Stratigraphic Surfaces

Required licenses: OpendTect Pro, SSIS.

### Exercise objective:

Extract systems tract boundaries as seismic horizons of OpendTect.

There are several ways available to extract stratigraphic surfaces (or horizons) from a HorizonCube.

In this exercise, you will learn three ways:

1. In SSIS window: **one horizon** at a time.
2. In SSIS window: **multiple** horizons.
3. In HorizonCube manager: **extract events**.

### Workflow:

#### Method 1:

1. In the SSIS window, **right-click** on the surface name and choose **Save as surface**.

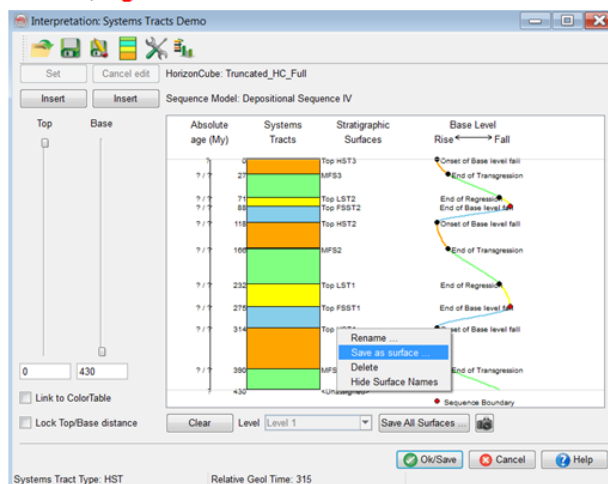

**Workflow cont'd:**

**Method 1:**

2. In save surfaces dialog, **specify a Horizon** name and **press OK**.

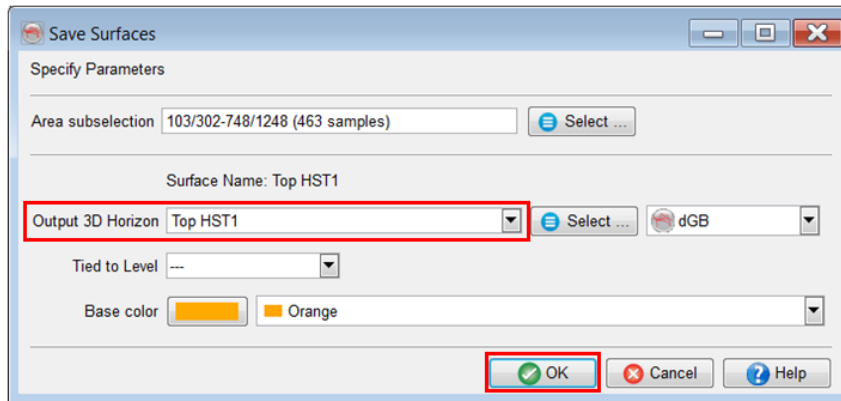

**Workflow cont'd:**

**Method 1:**

3. It will start extracting a horizon from the HorizonCube. In case, the HorizonCube is truncated, it will start interpolating the horizon.

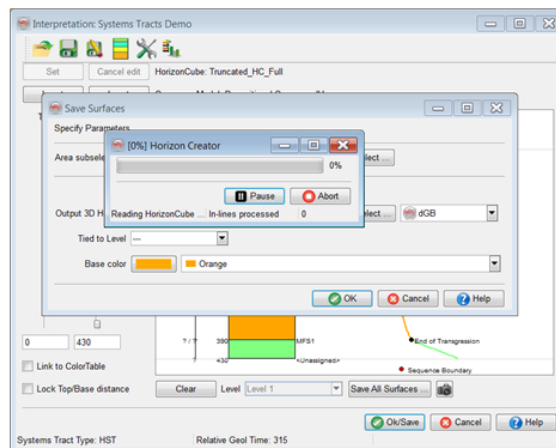

**Workflow cont'd:**

**Method 1:**

4. The extracted horizon is copied as a general OpenText horizon to the project database. Hence, you can **display the horizon** in the scene to QC it.

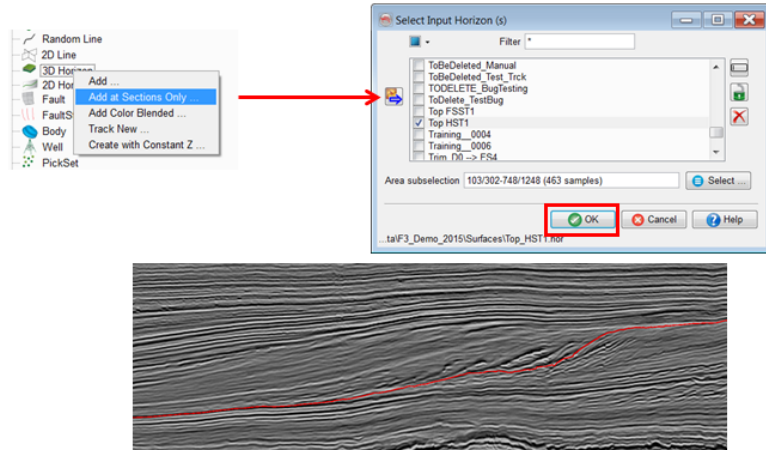

**Workflow cont'd:**

**Method 2:**

1. If you want to **save all surfaces**, then proceed with this part.

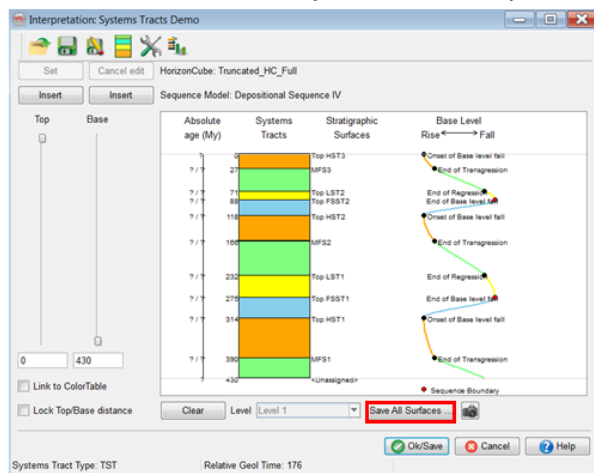

**Workflow cont'd:**

**Method 2:**

2. On the left panel, you see the surfaces names that you have interpreted. You will have to add them to the right. →
3. For each surface that is added, you will specify the **Output Horizon** name.

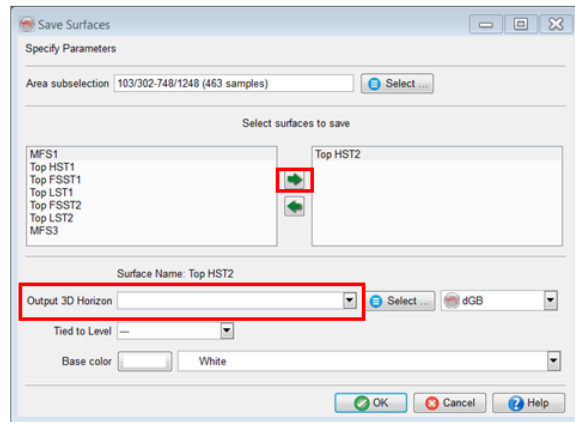

**Tip:** You can copy the input name for output horizon, e.g. MFS2 (using mouse drag over the label and CTRL+C).

**Workflow cont'd:**

**Method 2:**

4. Following this procedure, you can add multiple horizons in the list.
5. Once done, proceed by pressing the **OK** button.
6. It will output all of them as general OpendTect horizons and you can QC the outputs by displaying them in the scene as shown in **pt. 4 (Method 1)**.

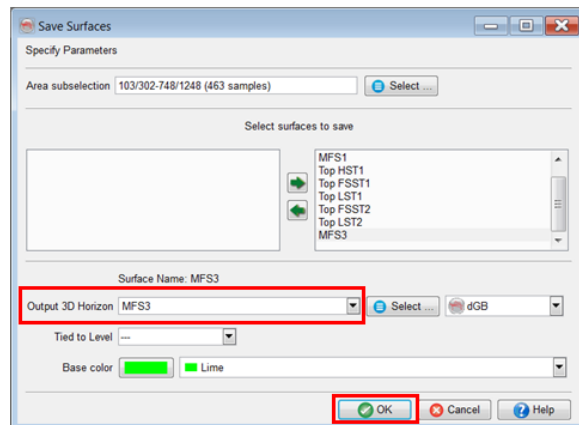



**Workflow cont'd:**

**Method 3:**

Directly extract horizons from a HorizonCube using **HorizonCube manager**.

1. Survey > Manage > HorizonCube > 3D
2. **Select Continuous\_HC\_Full & press copy to horizons icon.**

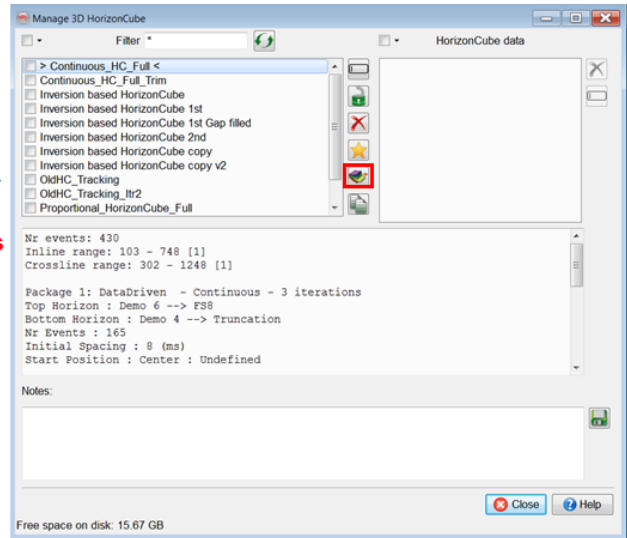
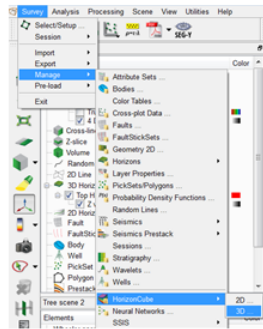

**Workflow cont'd:**

**Method 3:**

3. In the pop-up window you may choose one horizon or multiple horizons (say **Event 4** and **Event 6** only) to be converted to general OpendTect horizons. The **Base Horizon Name** is the prefix for the output horizon name. On **OK**, it will start extracting the horizons.
4. Once done, close this window.

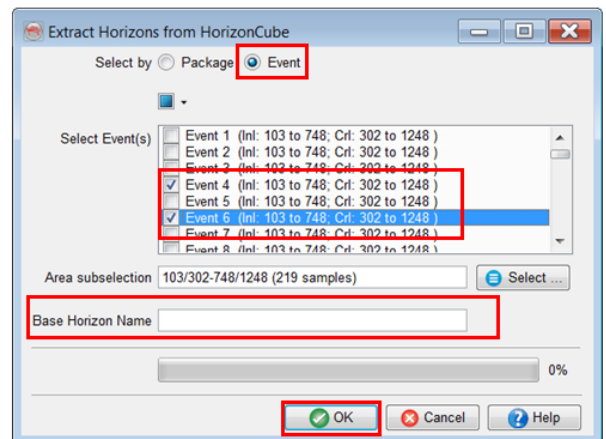

**Uncheck-all:** Ctrl+Z or uncheck the list through the small check box available at the top of the list.

**Group selection:** Mouse drag over the check boxes in the list.

**Workflow cont'd:**

**Method 3:**

5. To **QC** the outputs, you may want to display the extracted events in the scene as follow:

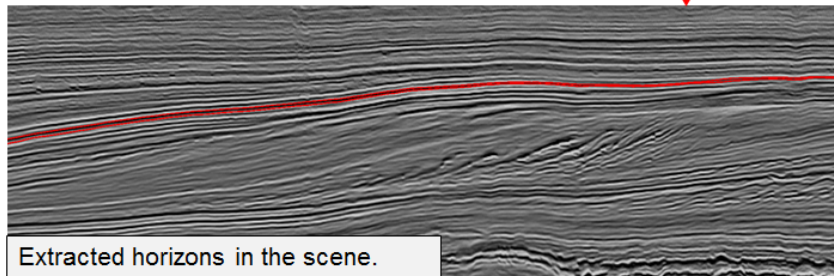
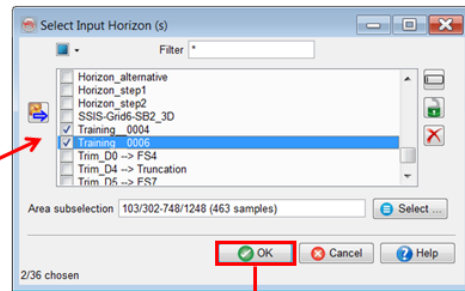
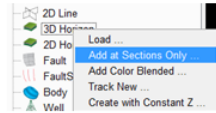

## 2.4.2g Stratigraphic Attributes

Required licenses: OpendTect Pro, HorizonCube.

### Exercise objective:

Define and understand the HorizonCube/SSIS attributes.

### Workflow:

1. Launch the **3D attribute** set window. 
2. **Select** a HorizonCube density attribute.

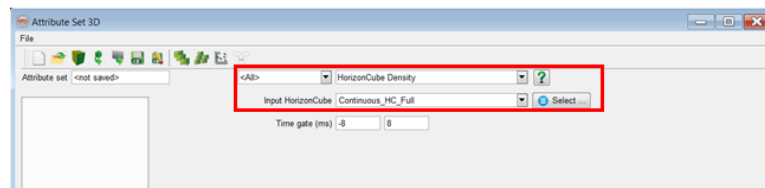

We suggest using a Continuous HorizonCube as an input for this attribute because it requires horizons within a specified time gate. The truncated HorizonCube removes such events and hence this attribute is not suitable for such inputs.

### Workflow cont'd:

3. **Specify** the attribute name and **add it as new**.

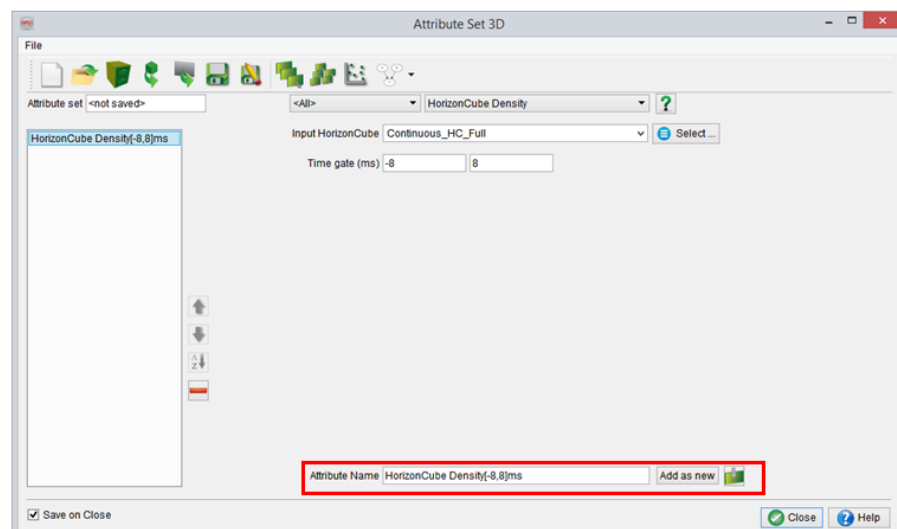

**Workflow cont'd:**

- Following the previous steps (2-3), **define\*** a few more attributes e.g. HorizonCube layers and Systems tract (Common ID, Unique ID, and Isochron) attributes.

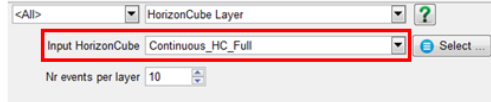

Note the input HorizonCube for this attribute is the truncated one because the interpretation is made on that input.

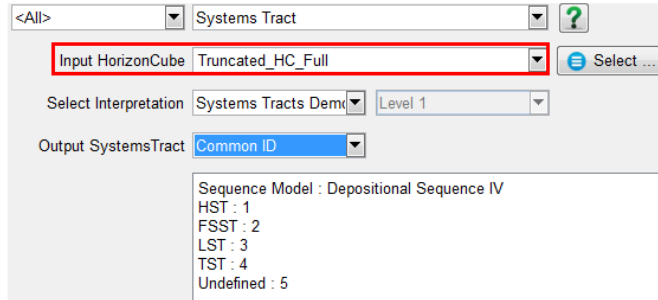

\* Per defined attribute, you will have to specify its name and press the button add as new.

**Workflow cont'd:**

- Once you have defined these five attributes, **save**  the attribute set as e.g. *Stratigraphic Attributes*. If the name already exists, then overwrite.
- Close** the attribute set window.

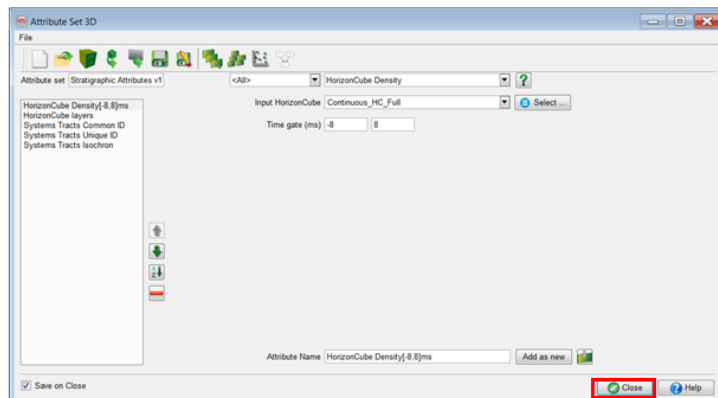
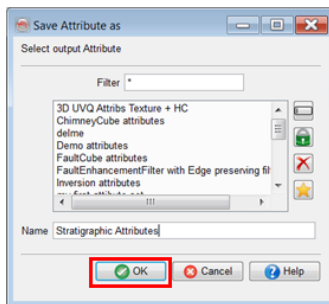

**Workflow cont'd:**

7. Next you may want to **display these attribute** on an inline before processing.

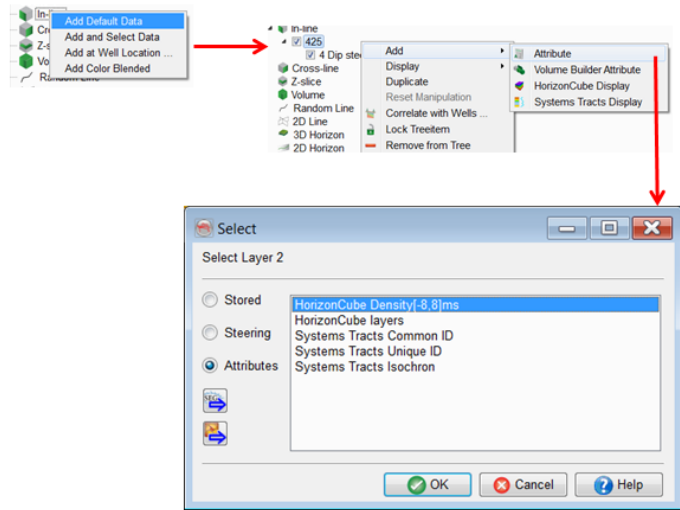

**Workflow cont'd:**

8. Following the same steps, **overlay the remaining** attributes on the same inline.

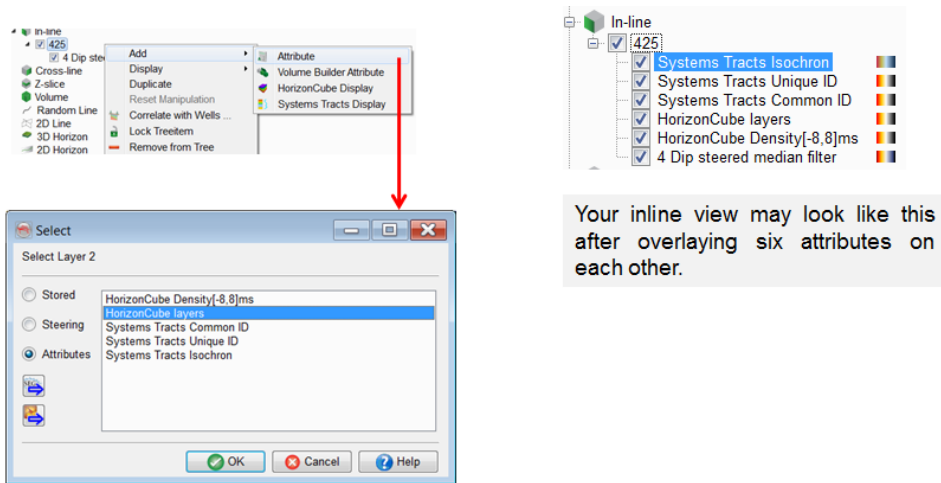

**Workflow cont'd:**

- Your attributes may have a **green/yellow** coloured (default undefined values) areas which could be set to transparent by following these steps.

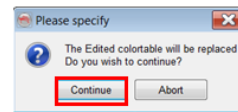
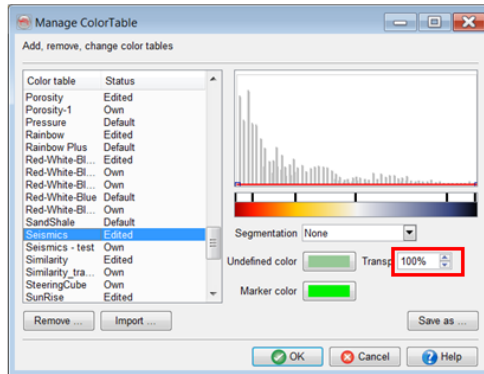
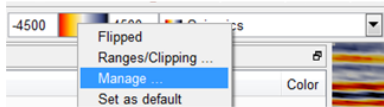

**Your results may look like this:**

**HorizonCube Density:**

Black regions in this case represents gaps in deposition e.g. unconformities and condensed sections.

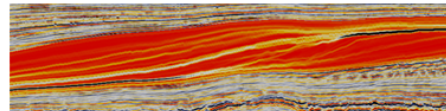

**HorizonCube Layers:**

This is like an input model containing layer definition per 10th event. A good input for geological/reservoir modeling.

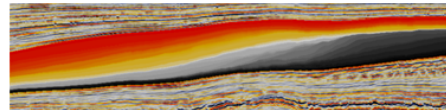

**Systems Tracts Comon ID:**

A repetition of same colour in this case represents the same systems tract, which has a common ID in this volume. Again, this volume can be use for modelling or prediction purposes.

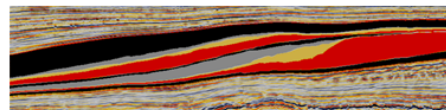

**Systems Tracts Unique ID:**

All systems tracts have their own unique IDs in this volume.

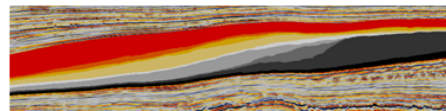

**Systems Tracts Isochron:**

This is a thickness volume per systems tract. A good product to explain the base-level variations based on your data. Or adding another dimension to the Wheeler diagrams when this attribute is used as an overlay in the Wheeler scenes (e.g. 4D Wheeler diagrams).

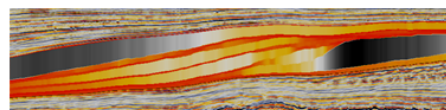

## 2.4.2h Stratal Slicing

Required licenses: OpendTect Pro, SSIS.

### Exercise objective:

Analyze 3D seismic data by slicing through all available data.

### Workflow:

1. **Go to** Processing > HorizonCube > 3D.
2. In the HorizonCube 3D Control Center **select** on Create a HorizonCube from the list and **click** Go...

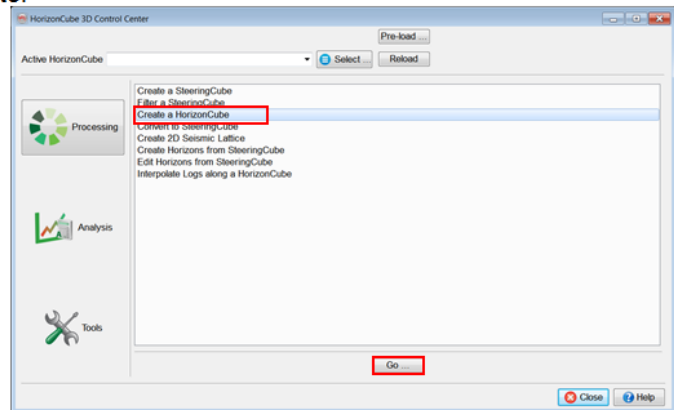
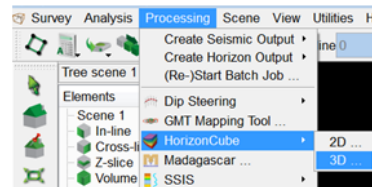

### Workflow cont'd:

3. In HorizonCube Creator, **click on** Read horizons...
4. **Check** three horizons Demo 4, Demo 6, Demo 7 and **click** OK.

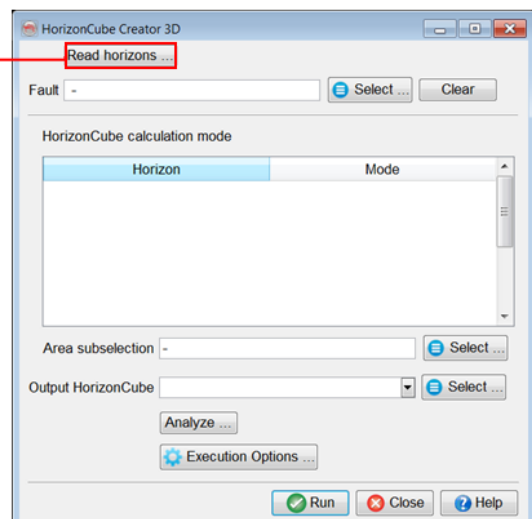
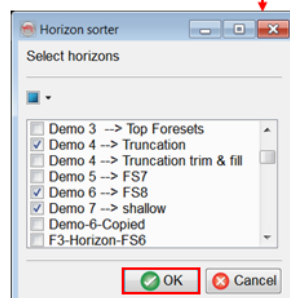

**Workflow cont'd:**

5. The table will be filled automatically with two packages. Select Model Driven: Proportional for the both the packages. **Type in** an output name to the HorizonCube *Proportional\_HorizonCube* and **press** Run to start the batch processing.

Settings for the proportional HorizonCube are based on event sampling (spacing at maximum thickness and fixed number of events).

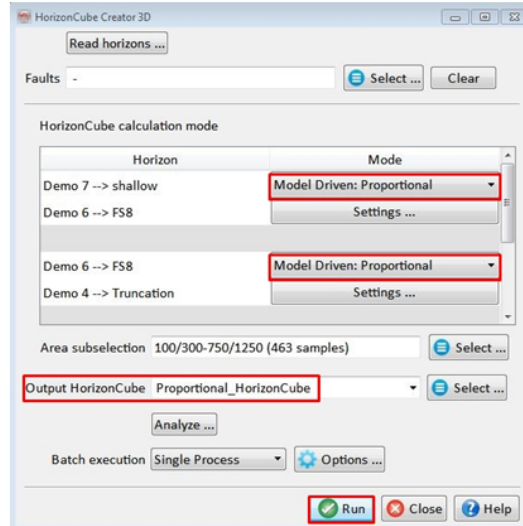

**Workflow cont'd:**

6. When processing is finished, **set** an active HorizonCube: **click** on Select button in HorizonCube 3D Control Center and **pick** *Proportional\_HorizonCube*.
7. **Press** Close.

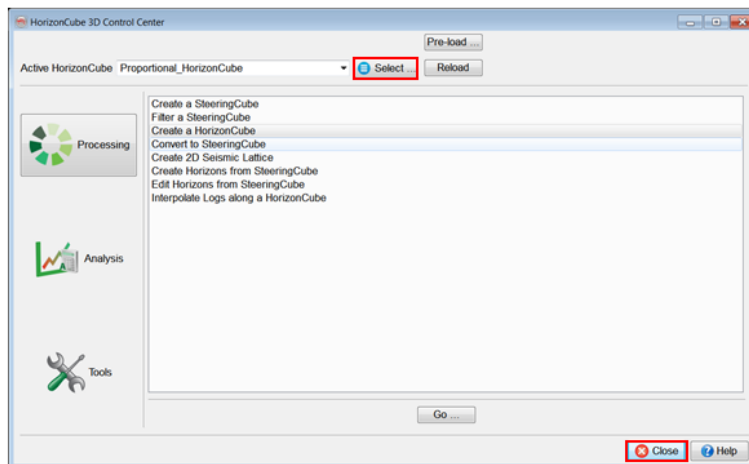



**Workflow cont'd:**

8. **Make** a Wheeler scene: Scene > New [Wheeler].

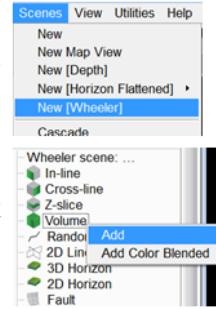

9. **Load** an empty volume in Wheeler scene: **Right-click** on Volume in the Wheeler scene tree > Add.

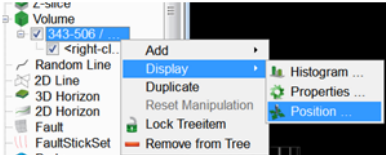

10. **Right-click** on the volume > Display > Position...

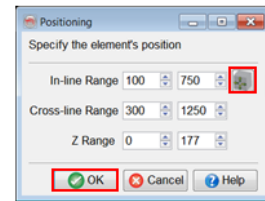

11. **Set** ranges to the full survey : **click** on the  icon and **press** OK.

**Workflow cont'd:**

12. **Select** 4 Dip steered median filter from the list of attributes and **press** OK.

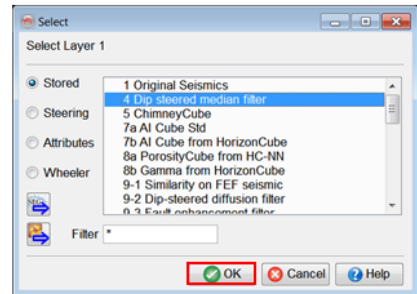

13. **Click** View Z or View North Z to rotate the volume.

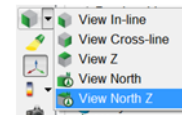

14. In mouse position mode , **click** on section and **pull down** to slice through. **Slice** the volume upward and downward.

In similar way you may slice in inline and crossline directions

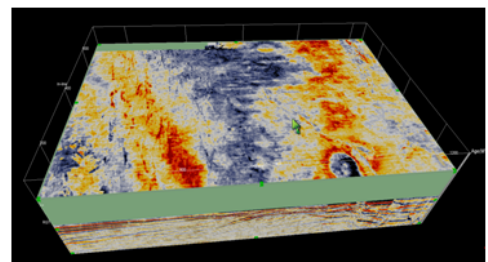

### Workflow cont'd:

Optionally a Wheeler Cube can be created as follows:

15. **Click** on  icon > 3D to launch Attribute Set window.
16. **Select** Similarity attribute from the attribute list.
17. **Type in** a name, e.g. *Similarity*, and press Add as new.
18. **Uncheck** Save on Close and **close** the window.

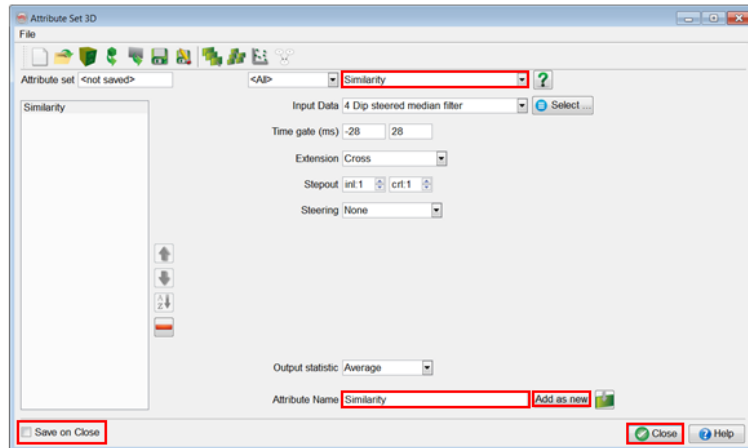
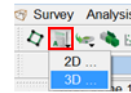

### Workflow cont'd:

19. **Create** wheeler volume: **go to** Processing > SSIS > Create Wheeler Output > 3D.

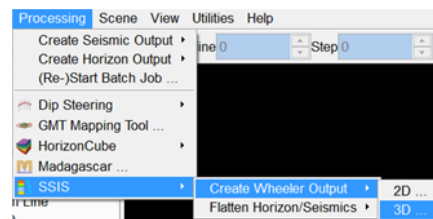

20. **Fill** the required fields as shown below and **press** OK to start processing.

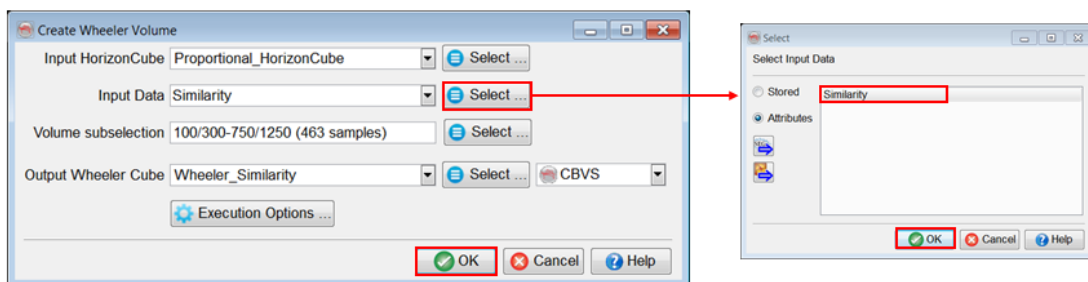

**Workflow cont'd:**

21. **Display** the *Wheeler Similarity* cube in a volume by selecting the attribute from the Wheeler tab:

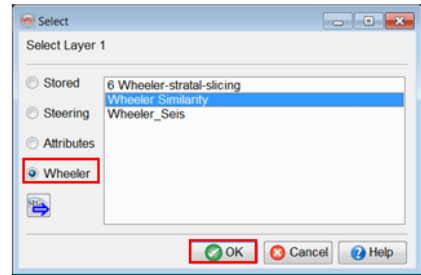

22. **Click** on *Wheeler\_Similarity* attribute in the tree to make it active and **change** the color bar to *Similarity*.

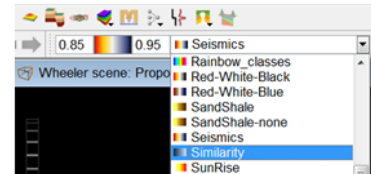

23. **Slice** the volume upward and downward for the z-axis to see geomorphologies.

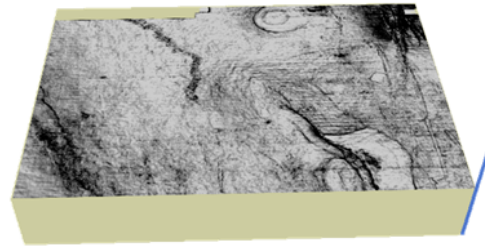

## 2.5.1a Coloured Inversion

Required licenses: OpendTect Pro, Seismic Coloured Inversion.

### Exercise objective:

Invert the seismic data to relative acoustic impedance using SCI plugin.

### Workflow:

1. **Launch** the *Attribute Set 3D* window.
2. **Choose** *Coloured Inversion* from the Attribute list.
3. For Input Data **click** Select and **choose** *1 Original Seismics*.
4. **Toggle** the *Single Operator* option to create a global SCI operator.
5. **Click** on **Analyze and Create ...** to launch the SCI main window.

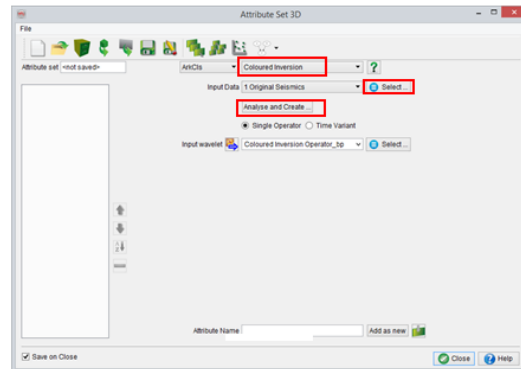
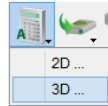

### Workflow cont'd:

In order to design an operator with the SCI application, it is first necessary to select and analyze the seismic and well data spectra. This is achieved by loading some seismic trace data and well log impedance data (in time).

6. **Click** on  to pop up the *Select Input Data* window.
7. **Check** if *1 Original Seismics* is selected.
8. **Click** Load Seismic to load the default 40 traces.
9. For *Time Range* **toggle** *Sub* and **enter** 500 and 1500 ms as range *Start* and *End* respectively.

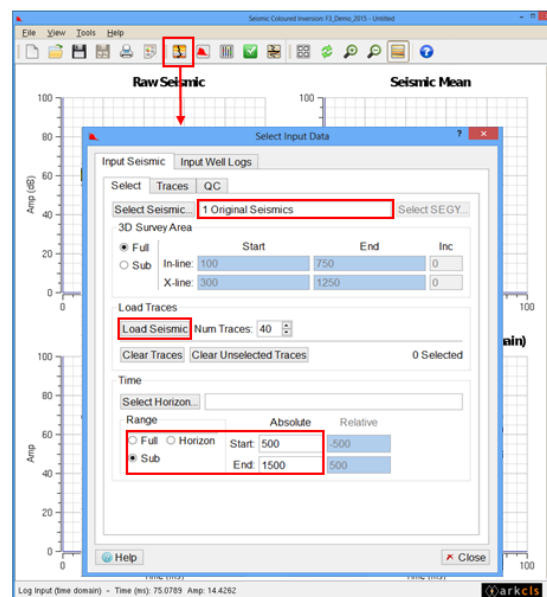

**Workflow cont'd:**

10. **Switch** to *Input Well Logs* tab.
11. **Click** *Load wells*.
12. **Select** the well F3-04 and **choose** *P-Impedance* log.
13. For *Time Range* **toggle** *Sub* and **enter** 500 and 1500 ms as range *Start* and *End* respectively.
14. **Close** the *Select Input Data* window.

You can add, generate new log from select input data window. Right click on any of the wells, then you can chose to add or create a new AI logs.

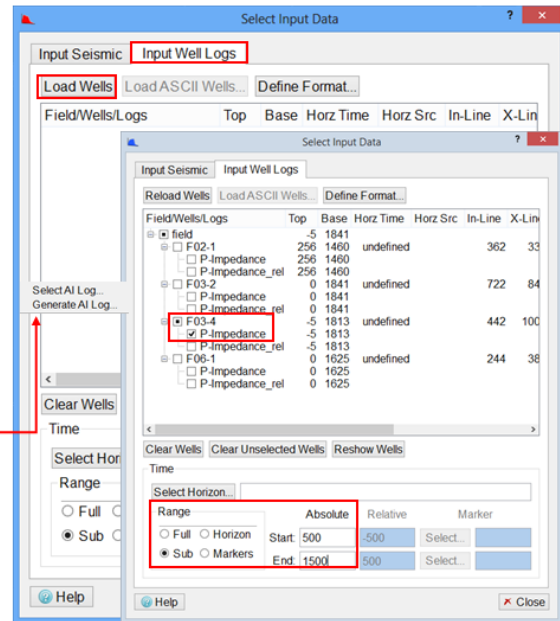

**Workflow cont'd:**

15. **Click** on the advanced controls icon  to choose the seismic sampling rate for the well log data resampling.
16. **Go to** Time Domain tab.
17. Log Data Resampling should be **set** to Interval Source: Seismic. Once set, close this dialog.

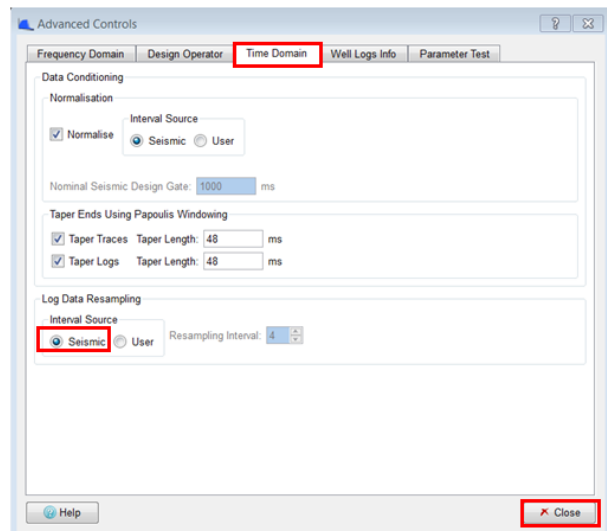

**Workflow cont'd:**

18. Click on  to pop up the Design Controls Dialog.

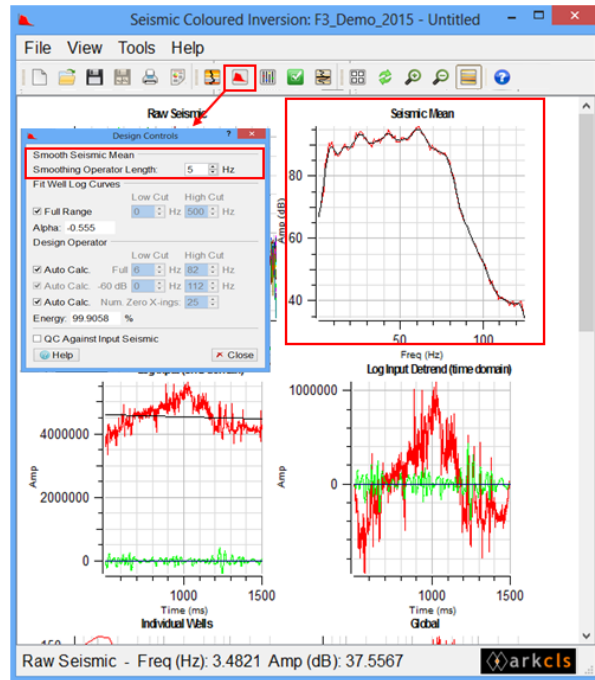

19. Smooth the amplitude-frequency plot of seismic data by setting an appropriate Smoothing Operator Length (keep an eye on the Seismic Mean curve).



**Workflow cont'd:**

As a rule of thumb, any Operator (time domain) larger than 200 is too high. You can adjust the operator by changing the number of zero crossings.

20. Tweak other parameters (low cut, high cut) of the design operator such that it overlaps the seismic bandwidth (check in the Seismic Mean curve) and the residual (Blue curve in QC) is nearly zero.

21. Save the Operator  and optionally you can save the session .

22. Close the SCI main window.

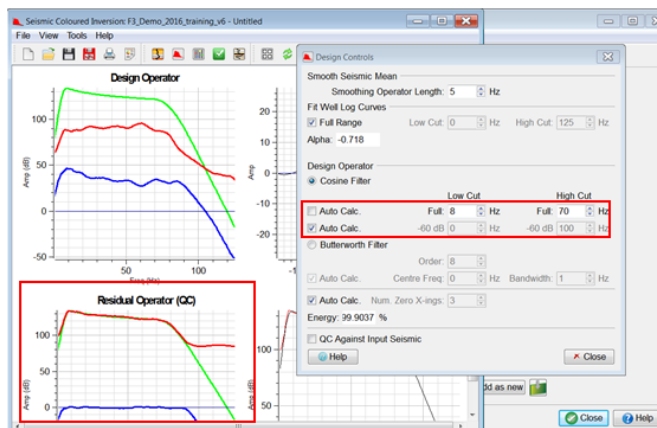

**Workflow cont'd:**

23. You will return to the attribute set window.

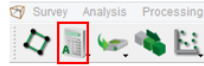

24. The input wavelet will already be selected for you.

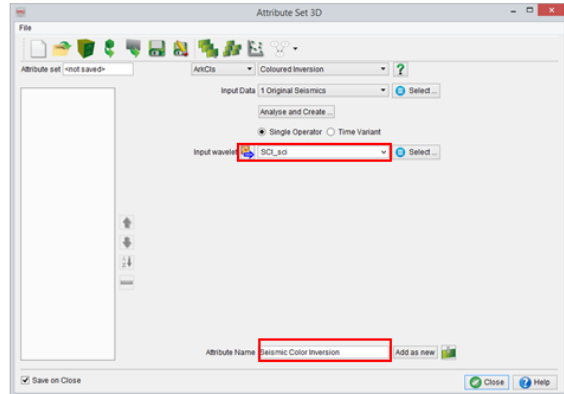

25. **Give** a name to the new attribute and **Add as a new**.

**Workflow cont'd:**

26. **Save** the attribute set by clicking  icon.

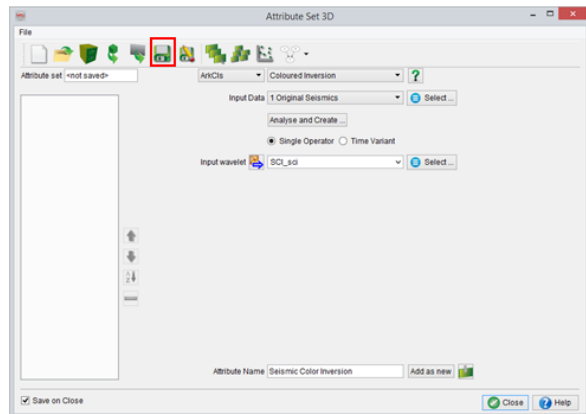

**Workflow cont'd:**

27. A new window will pop up, **Name** your attribute set and **press OK**.

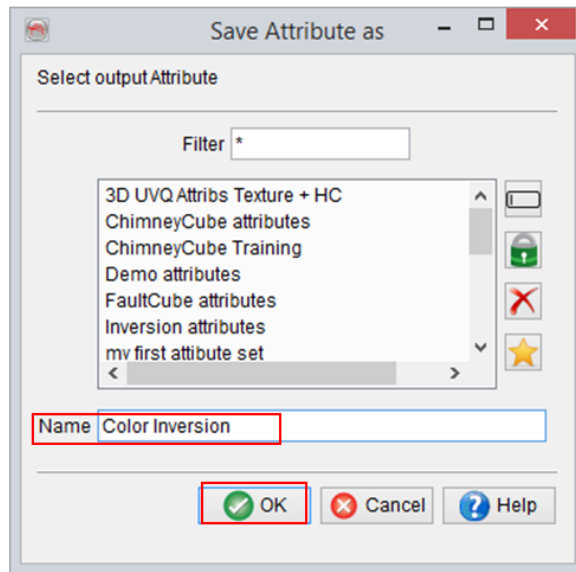

**Workflow cont'd:**

28. **Add** an inline in the tree (Inline > Add).

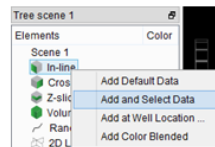

29. **Right-click** on the empty attribute for inline 425 and **follow** Select Attribute > Stored Cubes > 1 Original Seismics.

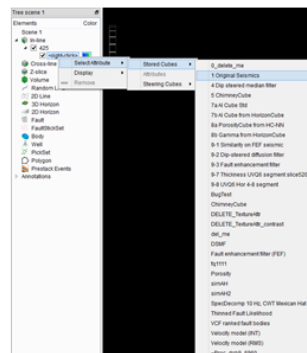

30. **Right-click** again on inline 425 and **select** the color inversion attribute that you have just created (Select Attributes > Attributes > Seismic Color Inversion).



---

**Workflow cont'd:**

31. Now you can see the results, and compare it with original data

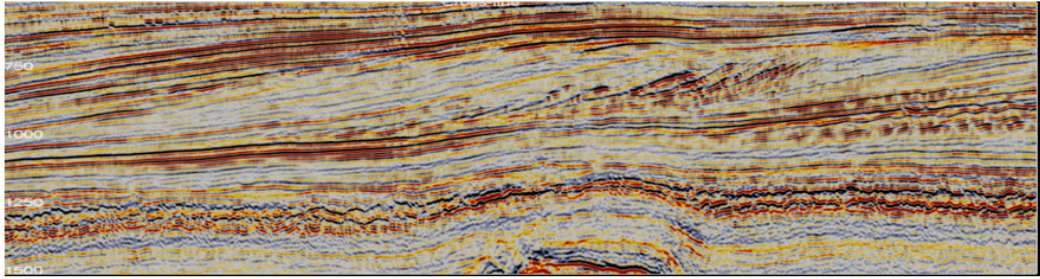

a. Original Seismic

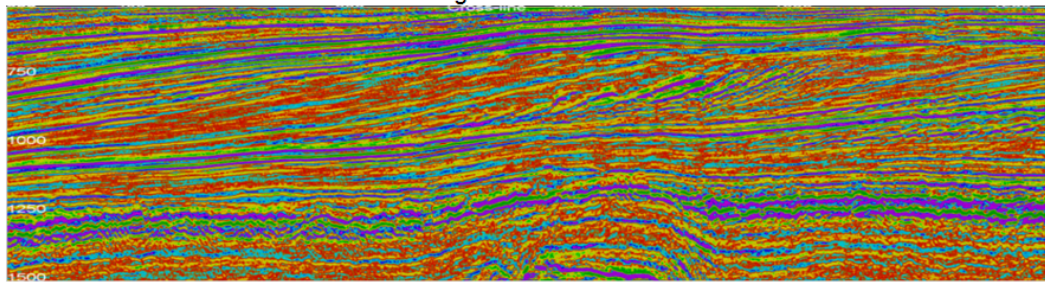

b. Colored Inversion of the Seismic

## 2.5.2a Extracting Horizontal Variograms

Required licenses: OpendTect Pro, Deterministic Inversion.

### Exercise objective:

Extract horizontal variogram parameters from color inverted grids.

1. **Extract** an attribute map using Stratal Amplitude. **Go** to Processing > Create Horizon Output > Stratal Amplitude.
2. In the pop up window, **select** the quantity to output.
3. In the Attributes section, **select** *Seismic Coloured Inversion*.

See exercise 2.5.1 on how to define the Coloured Inversion attribute.

4. **Hit** OK.

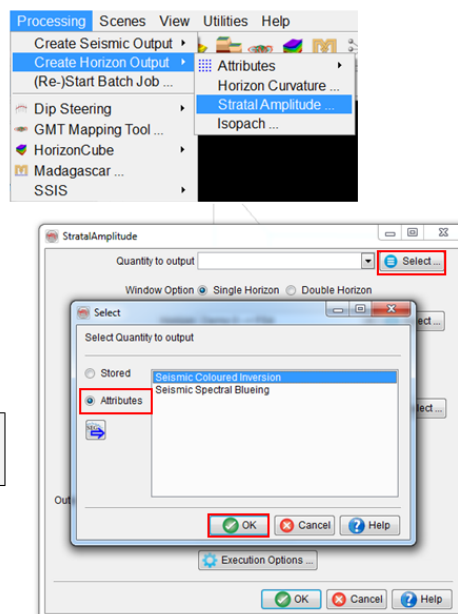

### Workflow cont'd:

5. **Keep** the window option as default, i.e Single Horizon.
6. **Select** the target horizon: *Demo 0 --> FS4* Horizon.
7. **Set** offset top: -20, bottom: 20 ms.
8. **Select** the amplitude option to output: Max.
9. **Name** the attribute.
10. Start the process: **click** on OK.

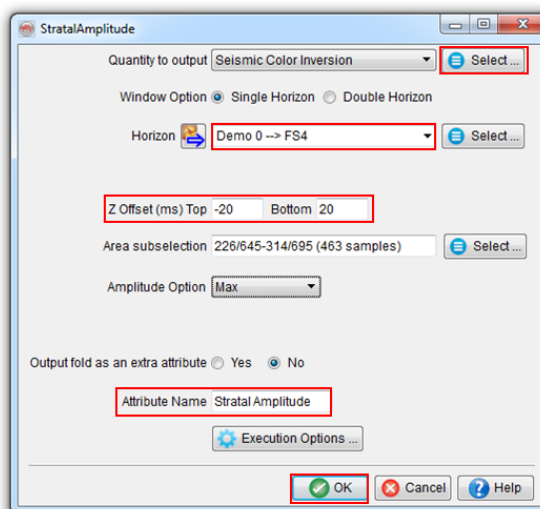

**Workflow cont'd:**

11. In the tree, **Right-click** on 3D Horizon and select **Load**.

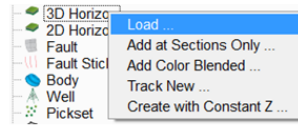

12. **Select** the horizon *Demo 0 --> FS4* and **Hit** Ok.

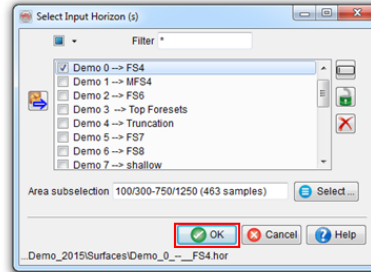

13. **Add** attribute at horizon location:  
**Right-click** on *Demo 0 --> FS4* > Add > Horizon Data.

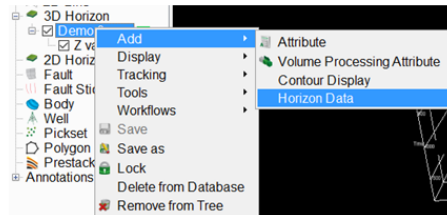

**Workflow cont'd:**

14. **Select** the *Stratal Amplitude* attribute you just created.

15. **Hit** OK.

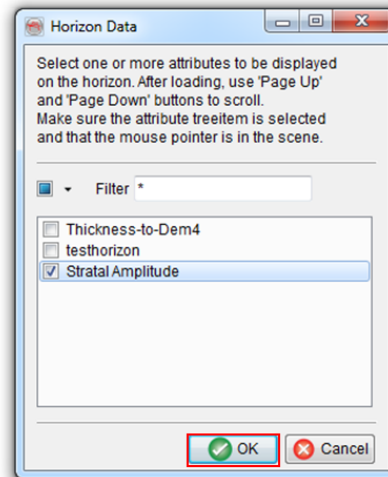

**Workflow cont'd:**

16. **Right-click** on *Stratal Amplitude* in the tree.

17. **Follow:** Tools > Variogram.

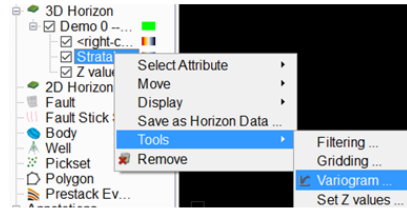

With this option, you access the horizontal variogram. It allows you to analyze lateral variability of your data around the horizon. This information is in particular used when building the background model for broadband seismic inversion.

18. **Hit** OK.

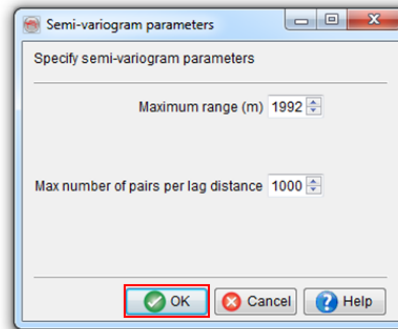

**Workflow cont'd:**

In this window, the objective is to fit a variogram model (Green) by setting its sill and range that best fit your data (Blue curve). Try to achieve a good fit at least for smaller lag distances. Mind the impact of number of pairs per lag on the smoothness of the data extracted curve.

19. The analysis can be done in different directions; Inline, Diagonal, or Crossline (i.e. the analysis is anisotropic) : **change** the direction and **observe** the impact on the variogram.

20. **Modify** sill and range, using the sliders, to fit a variogram model to the data.

21. **Choose** out of the three available variogram models; Exponential, Spherical and Gaussian.

Variogram parameters are used for example when building the initial model for MPSI inversion.

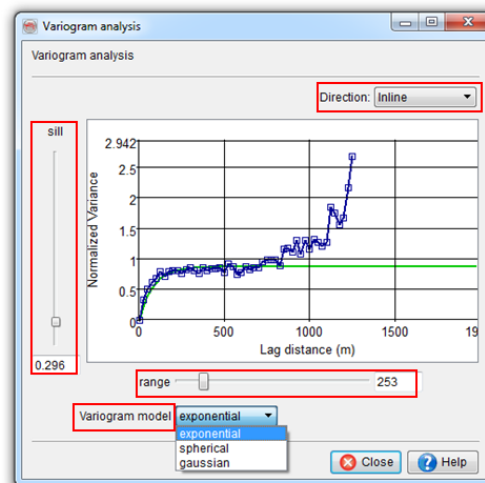

## 2.5.2b Extracting Vertical Variograms

Required licenses: OpendTect.

### Exercise objective:

Extract vertical variogram parameters from impedance well logs.

### Workflow:

1. To extract P-Impedance logs from various wells: **Go to** Analysis > Cross plot Data > Well logs vs. Attributes.

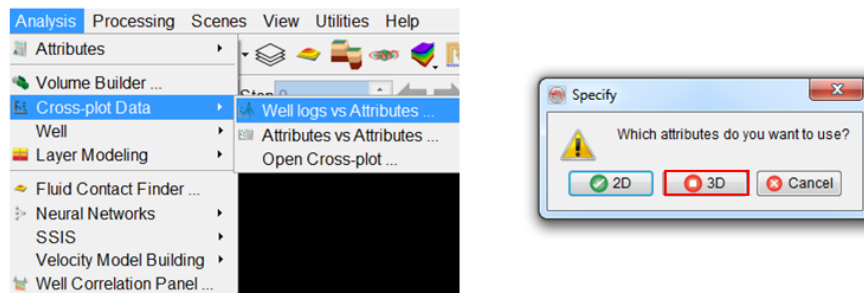

### Workflow cont'd:

2. **Select** all wells that will be used for data extraction.
3. **Select** Impedance logs associated with the wells.
4. **Toggle** Extract in time and **set** step: 1 ms.
5. **Extract** between Markers: FS8 and FS4.
6. **Select** log resampling method as Take Nearest Sample.
7. **Set** the radius around wells to 0 and **press** OK.

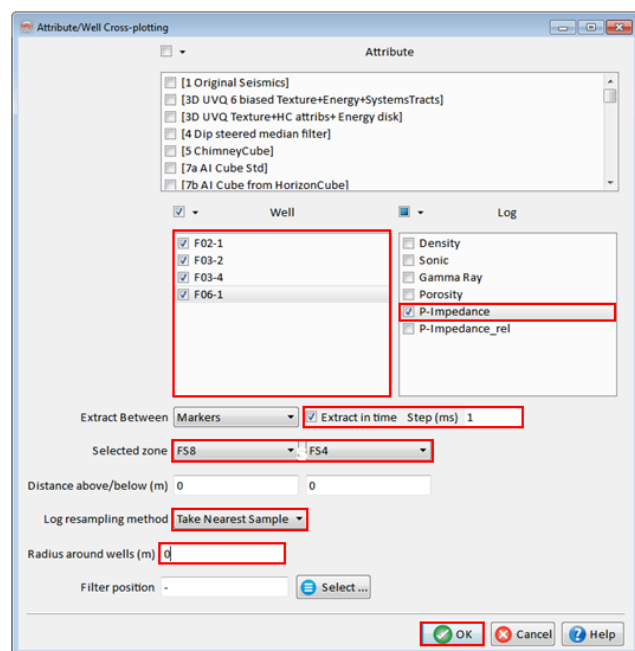

**Workflow cont'd:**

8. Cross plot table window pops up.
9. **Select** P-Impedance Column.
10. **Click** on this  icon to start the variogram analysis.
11. Variogram parameters window pops up.
12. **Click** OK.

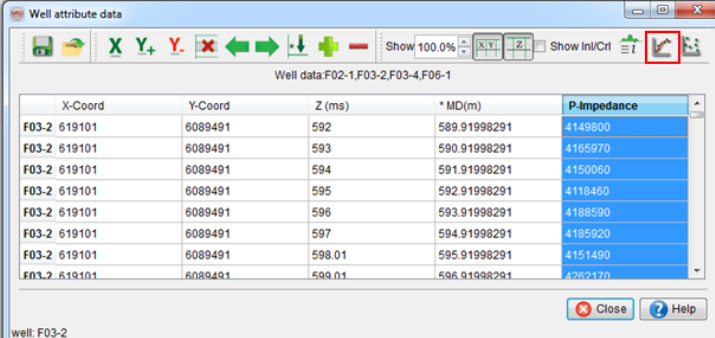

X-Coord	Y-Coord	Z (ms)	* MD(m)	P-Impedance
F03-2 619101	6089491	592	589.91998291	4149800
F03-2 619101	6089491	593	590.91998291	4165970
F03-2 619101	6089491	594	591.91998291	4150060
F03-2 619101	6089491	595	592.91998291	4118460
F03-2 619101	6089491	596	593.91998291	4188590
F03-2 619101	6089491	597	594.91998291	4195920
F03-2 619101	6089491	598.01	595.91998291	4151490
F03-2 619101	6089491	599.01	596.91998291	4282170

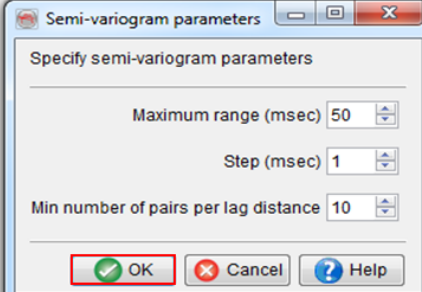

Specify semi-variogram parameters

Maximum range (msec) 50

Step (msec) 1

Min number of pairs per lag distance 10

OK Cancel Help

The vertical variogram parameters used here are comparable to the horizontal variogram analysis of Exercise 2.5.2a. The main difference is in the number of available data points. Variogram analysis requires a minimum number of pairs per lag distance and therefore sufficient data must be input in order to obtain a representative variogram.

**Workflow cont'd:**

13. The variogram analysis can be done for either all the wells (recommended) or for one particular well.
14. **Modify** sill and range, using the sliders, to fit a variogram model (Green) to the data (Blue).
15. **Choose** out of the three available variogram models; Exponential, Spherical and Gaussian.

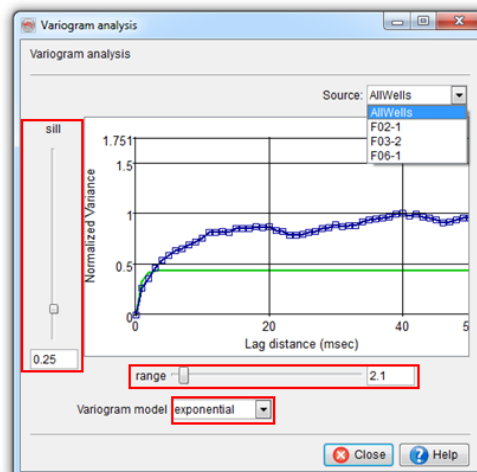

It's recommended to use the same model for this vertical variogram analysis, as used previously for horizontal variogram analysis (Exercise 2.5.2a).

## 2.5.3a Neural Network Prediction

Required licenses: OpendTect Pro, Neural Networks.



### Exercise objective:

To convert seismic information to porosity using a neural network inversion workflow.

#### Well data Preparation

1. **Well(s)** need to be available in the survey. If they are not available: **import** wells (track, logs, markers, optionally time-depth curve or checkshot).
2. **Tie** well to the seismic (see exercise 1.5.1).

#### Workflow:

1. **Open** attribute set window .
2. **Click** on file> *Open set* , or click on .
3. **Select** the saved set '*Inversion attributes*' and **Hit** Ok.

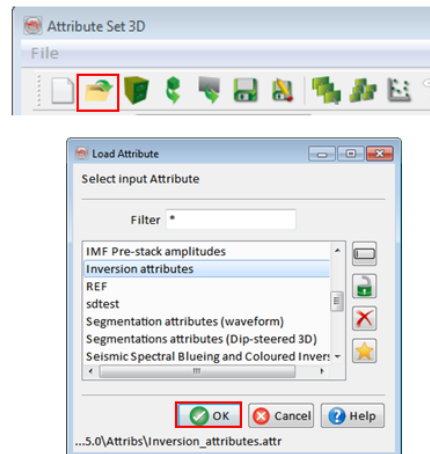

#### Workflow cont'd:

4. **Open** the neural network plugin with the  icon > 3D or **go to** Analysis > Neural Networks > 3D.
5. **Select** Property prediction [Well Data] from the Neural Network manager.

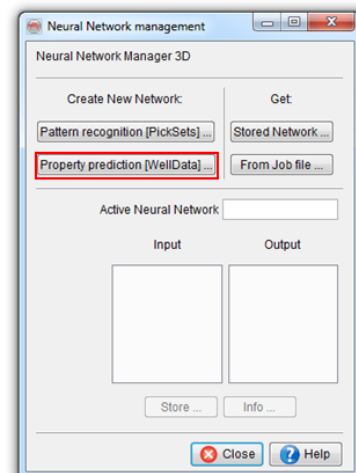
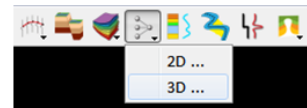

**Workflow cont'd:**

6. Data selection window pops up.

7. **Select** the input attributes as on the picture.

8. **Select** the target quantity among the available well logs: Porosity.

9. **Set** the percentage of data to be used as test set: 40%

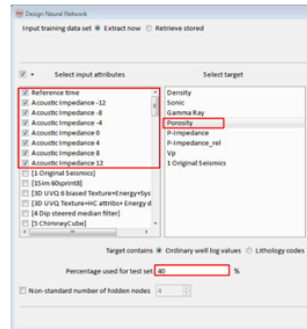
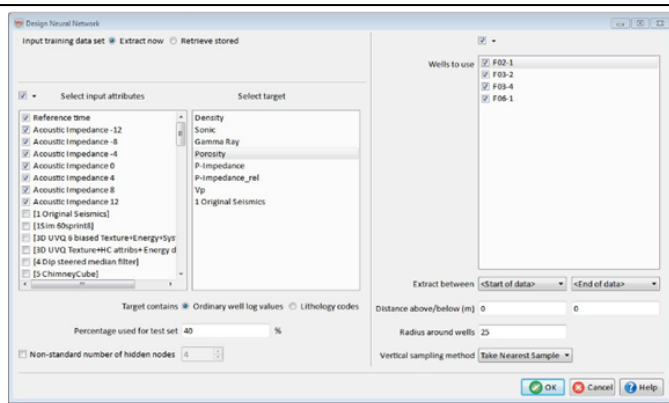

**Workflow cont'd:**

10. **Select** all the wells.

11. **Limit** the extraction window as shown on the picture.

12. **Select** Average Vertical sampling method and **Press** OK.

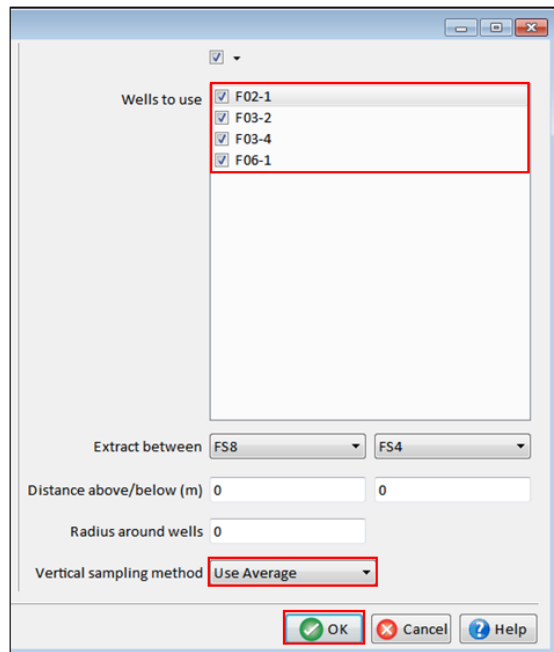



**Workflow cont'd:**

An optional step is to QC the extracted data set (tested and training) by plotting Acoustic Impedance (Y) versus Porosity (X)

13. **Highlight** Porosity column and press **X**.

14. **Highlight** AI 0 column, and press **Y+**.

15. **Click** on .

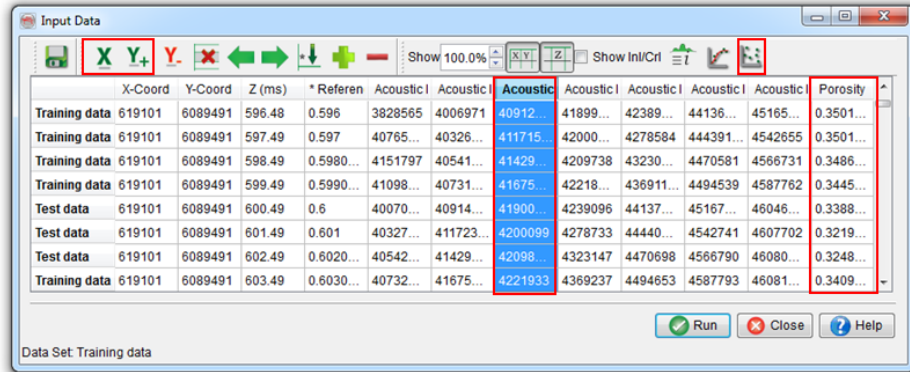

**Workflow cont'd:**

16. Cross plot window pops up.

17. **Click** on  in previous window to move Y column and see how other attribute plot against Porosity.

18. **Close** cross Plot window.

19. **Press** Run in Previous Window.

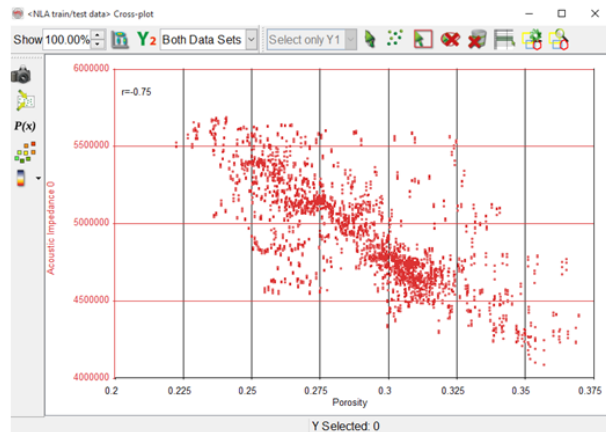

**Workflow cont'd:**

20. The balancing data window pops up.

In this step, you have the option to balance your data. If the data is not properly sampled, balancing is a recommended pre-processing step.

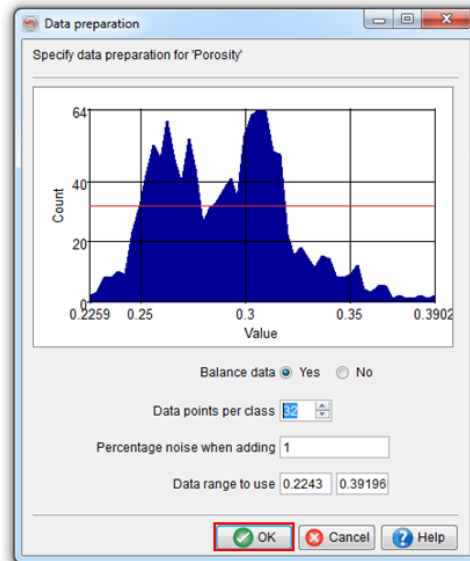

21. To continue, **Press** OK.

**Workflow cont'd:**

22. The Training data window pops up.

23. To continue, **Press** OK.

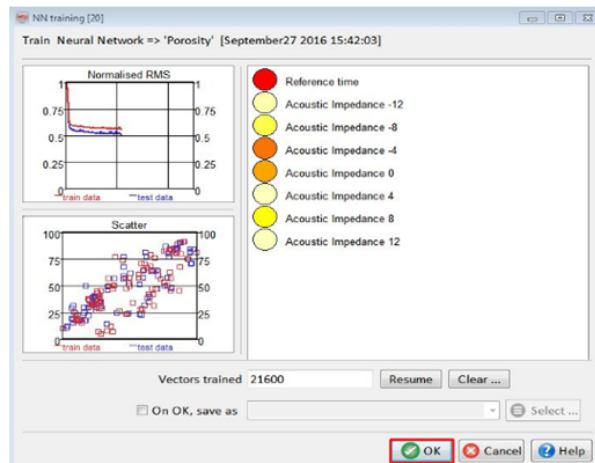

**Workflow cont'd:**

24. Back in the Neural Network, Output property is highlighted.

25. **Click** on *Info* to see summary Of Neural Network characterisation.

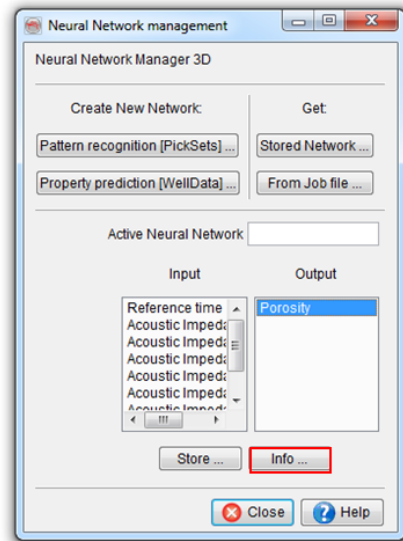

**Workflow cont'd:**

26. Neural Network info (report) pops up.

27. **Click** on Save Report (optional).

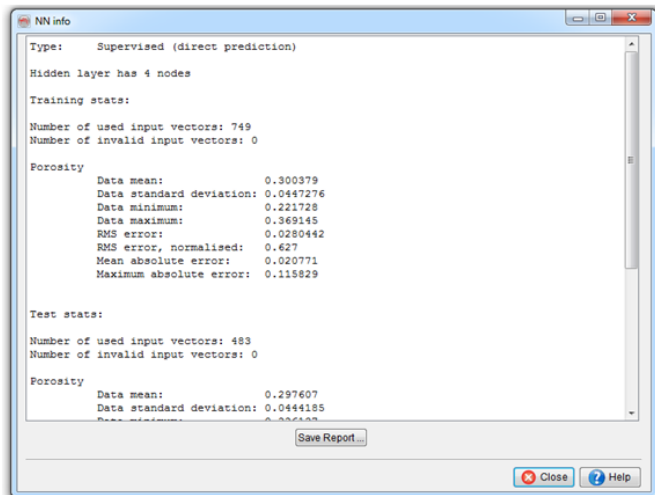

Workflow cont'd:

28. **Store** the Neural Network.

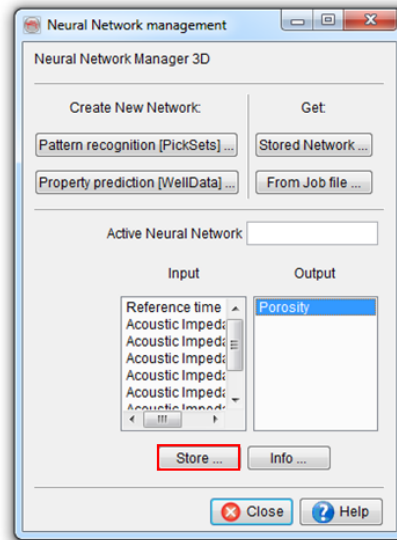

Workflow cont'd:

29. **Give** a name to the Neural Network output.

30. **Press** OK.

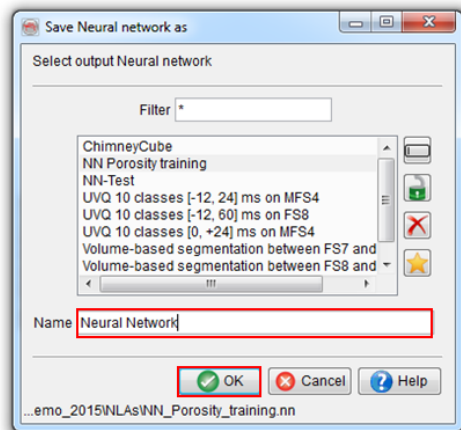

**Workflow cont'd:**

31. **Create** Porosity Cube.

32. **Create** seismic output using:

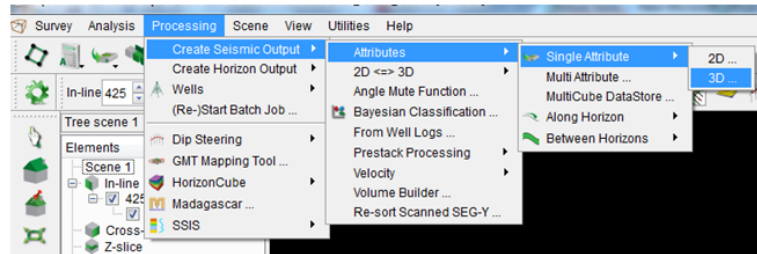

**Workflow cont'd:**

33. **Select** quantity to output

34. New window pops up.

35. **Toggle** Neural Network.

36. **Select** Porosity.

37. **Press** OK.

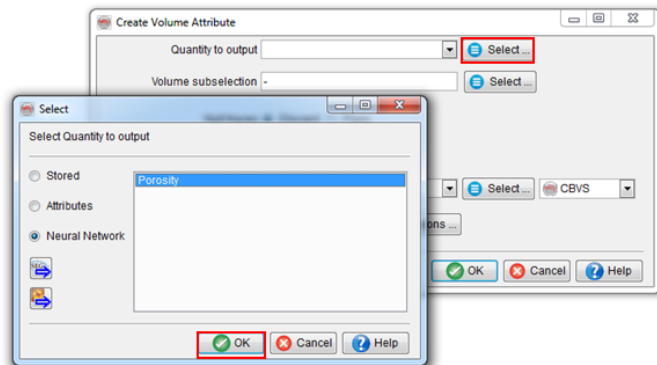

**Workflow cont'd:**

38. **Give** a name to the output Cube.

39. **Press** Ok.

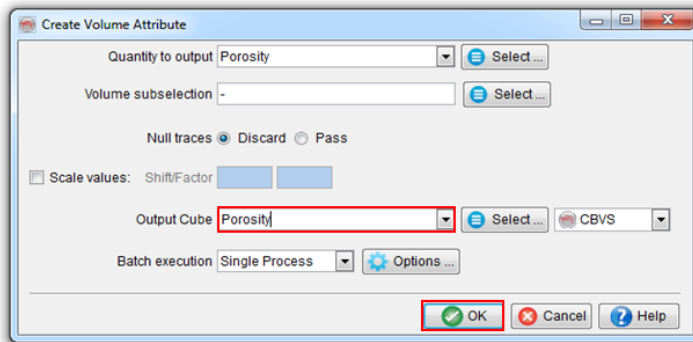

**Workflow cont'd:**

40. To apply the output on an inline to perform QC by giving **Right click** on Inline > Add and Select data.

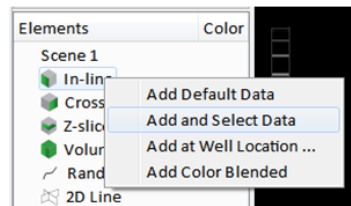

41. In the selection window, under the Neural network category, **select** Porosity and **Press** Ok.

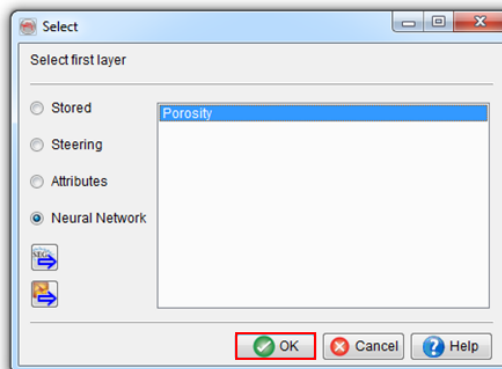

---

**Workflow cont'd:**

42. The Porosity prediction result display on *Inline 425* should look like the image below.

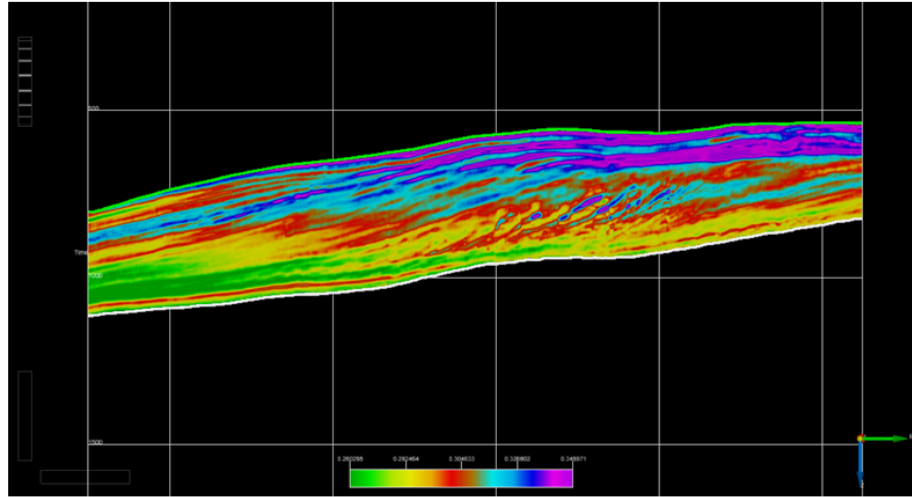

## 2.6.1 Well workflows

The Well Log Prediction workflows in this section are Supervised Machine Learning workflows and require only well logs as inputs.

The target logs are used for generating/predicting missing logs.

Log Prediction produces continuous logs.

## 2.6.1a Log-Log Density

Required licenses: OpendTect Pro & Machine Learning

### Exercise objective:

To predict missing logs using the log-log prediction tool, which is part of the machine learning plugin. In this case, we want to predict the Density log.

### Well data Preparation

Well(s) need to be available in the survey. If they are not: **import** wells (track, logs, markers, optionally time-depth curve or checkshot).

### Workflow:

1. **Open** the Machine Learning Control Center with the  icon.
2. **Click** on Wells.
3. **Select** Log-Log prediction, and **Hit** Go.

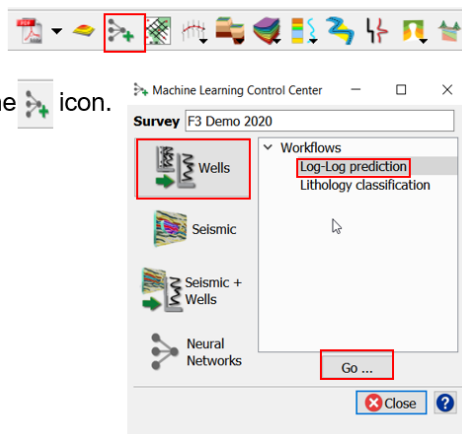

### Workflow cont'd:

4. **Press** Select - Input Data in the "Log-log prediction" window. **Select**  icon in the "Target Log Definition".
5. In the "Specify Log Data to predict" window, **Select** Survey\*, Target Log (e.g. Density), and the Wells that will be used for the data extraction.

The well F02-1 is not selected, and will be used as a blind well.

6. **Press** OK.

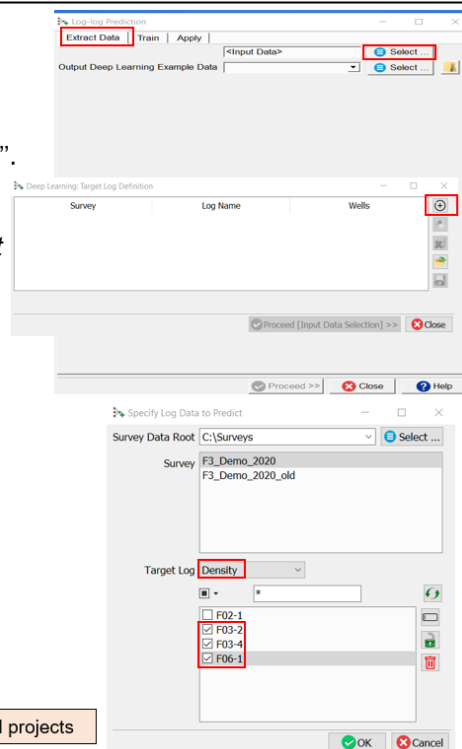

\* The option to select data from other surveys is available only in commercial projects



**Workflow cont'd:**

7. "Deep Learning: Target Log definition" window pops up.

A new data from different survey\* can be added by clicking on  icon.

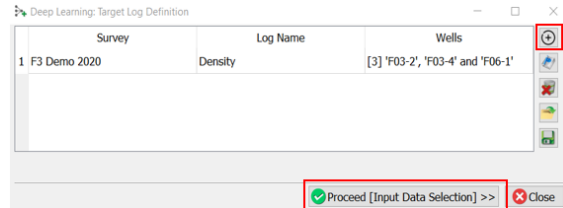

8. **Press** Proceed [Input Data Selection].

9. In the "Select Input Logs" window, **Select** logs that will be used to predict 'Density' log (e.g. *Sonic*, *Gamma Ray*).

10. **Press** OK.

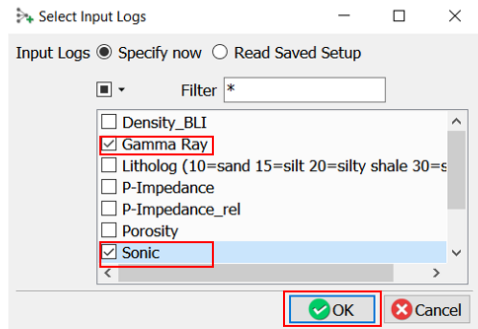

\* The option to select data from other surveys is available only in commercial projects

**Workflow cont'd:**

11. "Input Log Selection" window pops up.

Input Logs can be modified in here. Keep the default parameters as indicated in this window.

12. **Type** a new name for the *Output Deep Learning Example Data* (e.g. *DL\_Example\_Density\_st10*).

13. **Press** Proceed.

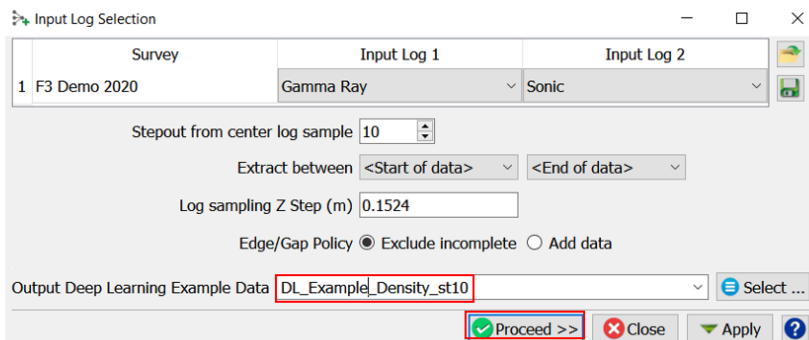

**Workflow cont'd:**

14. The *Train* tab get activated. Train the extracted examples data using suitable learning algorithm. Keep the defaults parameters, "Scikit-learn" platform and "Random Forest" Model.

Different machine learning platforms and parameters can be tested.

15. **Specify** a new *Output model* name (e.g. DL\_Model\_ScikitLearn\_RandomForests).

16. **Press** Run.

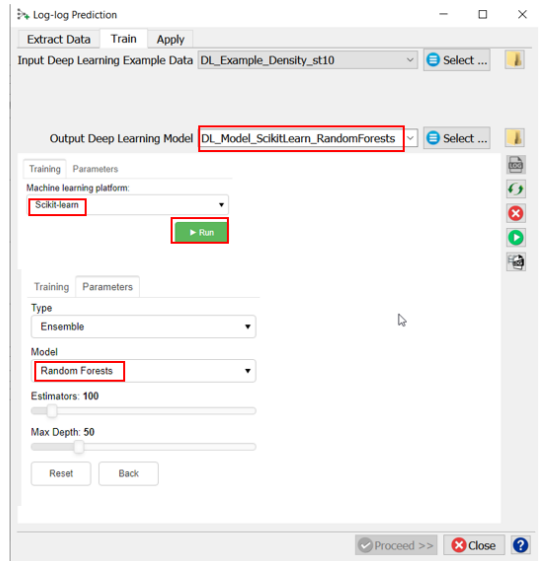

**Workflow cont'd:**

17. **Press** "Apply" tab  
Check all the selected default parameters are Ok.

\*The Survey and Training model can be modified in here.

18. **Press** Proceed.

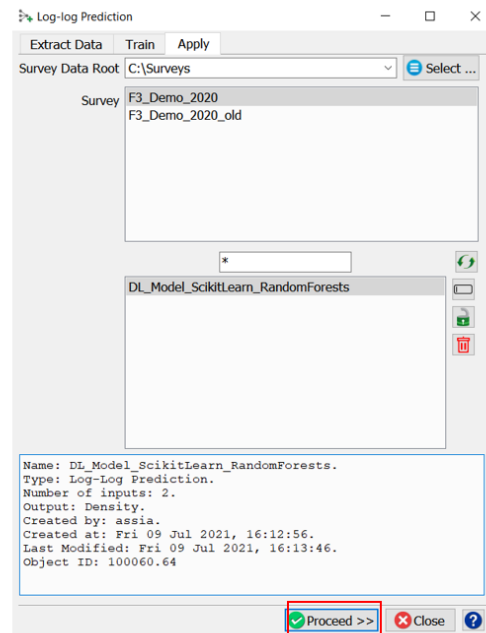



\* The option to select data from other surveys and training model is available only in commercial projects

**Workflow cont'd:**

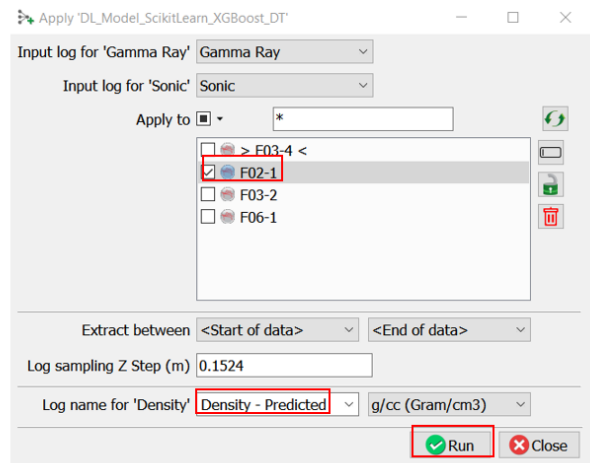
19. "Apply training model" window pops up.
20. Apply the trained model to a blind well. **Select** F02-1.
21. **Type** a new name for the predicted log (e.g. Density\_Predicted).
22. Keep default parameters and **Press** Run to continue.



**Workflow cont'd:**

23. QC results by displaying the predicted log adjacent to the recorded log
24. **Click** on the Well Manager icon .
25. **Select** the well "F02-1" and the logs "Density" and "Density-Predicted".
26. **Click** on view logs icon .

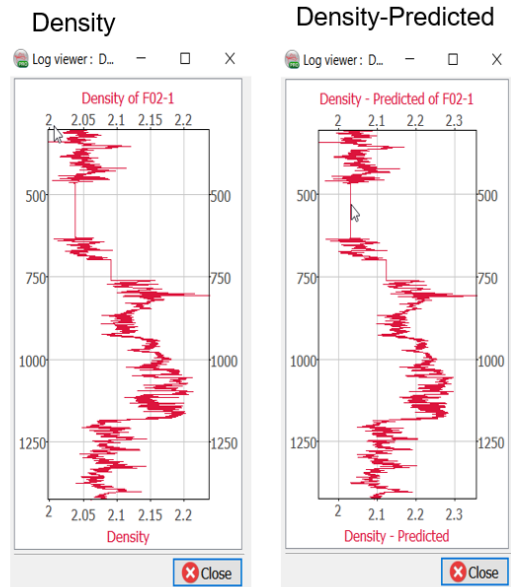
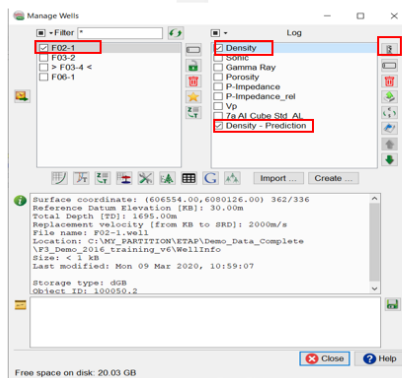

**Workflow cont'd:**

If result is satisfactory, go back to the "Apply training" window, and apply the trained model to all the wells where you want to predict density log.

- 27. **Select** all wells.
- 28. **Type** a new name (e.g. Density\_Predicted). Keep default parameters and **Press** Run to continue.

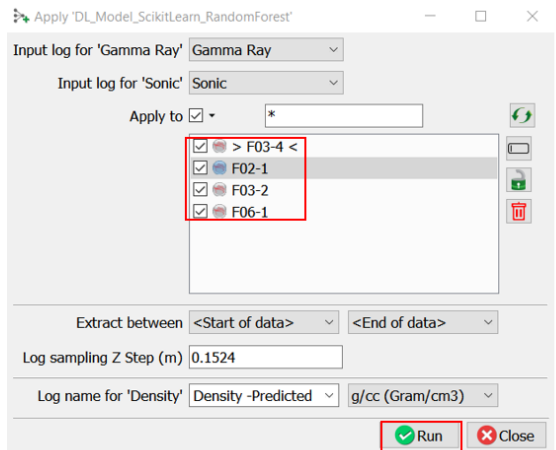

## 2.6.1b Log-Log Porosity

Required licenses: OpendTect Pro & Machine Learning

### Exercise objective:

To predict missing logs using the log-log prediction tool, which is part of the machine learning plugin. In this case we want to predict the Porosity log.

### Well data Preparation

**Well(s)** need to be available in the survey. If they are not available: **import** wells (track, logs, markers, optionally time-depth curve or checkshot).

### Workflow:

1. **Open** the Machine Learning Control Center with the  icon.
2. **Click** on Wells.
3. **Select** Log-Log prediction and **Hit** Go.

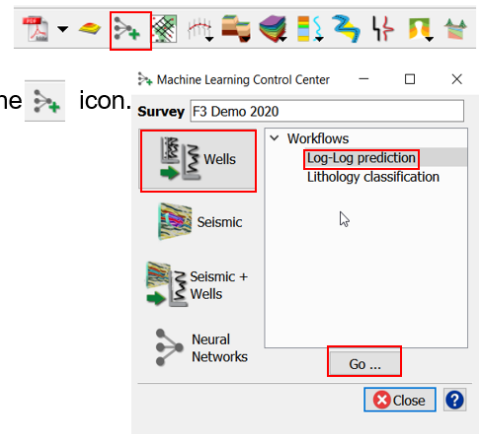

### Workflow cont'd:

4. "Log-log prediction" window pops up.
5. Press **Select** - Input Data in the "Log-log prediction" window. **Select**  icon in the "Target Log Definition".
6. "Log Data to predict" window pops up.
7. In the "Specify Log Data to predict" window, **Select** Survey\*, Target Log (e.g. Porosity), and the Wells that will be used for the data extraction.

Well F02-1 is not selected, and will be used as a blind well.

8. **Press** OK.

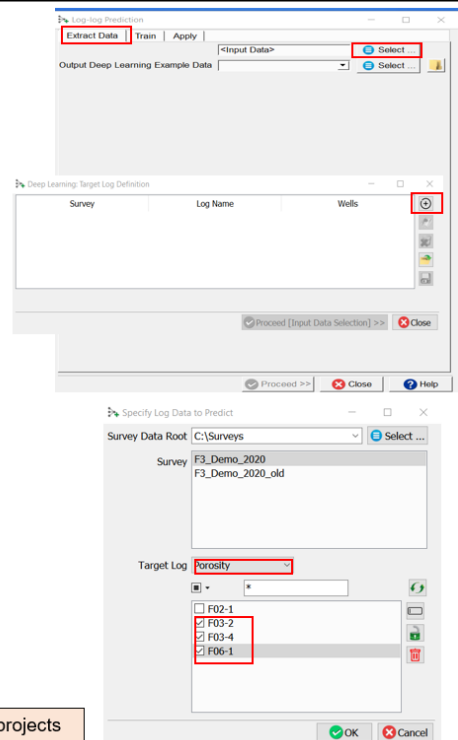

\* The option to select data from other surveys is available only in commercial projects

**Workflow cont'd:**

9. "Deep Learning Target Log definition" window pops up.

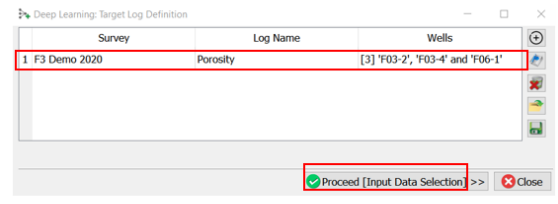

10. **Keep** the default parameters and **Press** Proceed [Input Data Selection].

11. *Select Input Logs* window pops up.

12. **Select** the Density, *Sonic* and *Gamma Ray* logs that will be used to predict the 'Porosity' log.

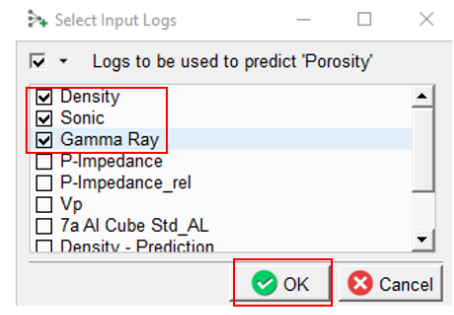

13. **Press** OK.

**Workflow cont'd:**

14. *Input Log Selection* window pops up.

Input Logs can be modified. Keep the default parameters as indicated in this window.

15. **Type** a new name for the *Output Deep Learning Example Data* (e.g. *DL\_Example\_Data\_Porosity\_st10*).

16. **Press** Proceed.

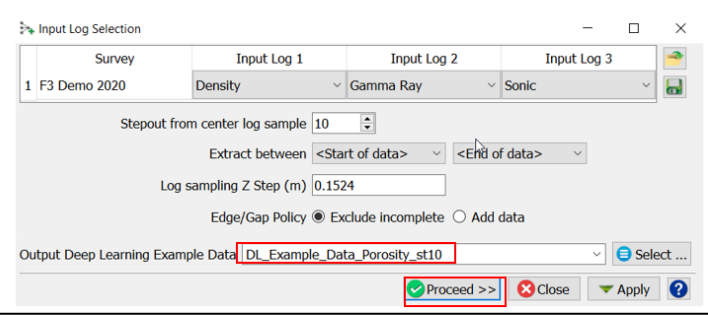

**Workflow cont'd:**

- 17. The *Train* tab opens. Select the Machine learning platform: Scikit-learn (Random Forests).

Different machine learning platforms and parameters can be tested.

- 18. **Keep** the defaults parameters. **Enter** new *Output model* name (e.g. Model\_Porosity\_from\_DEN\_DT\_GR).
- 19. **Press** Run.

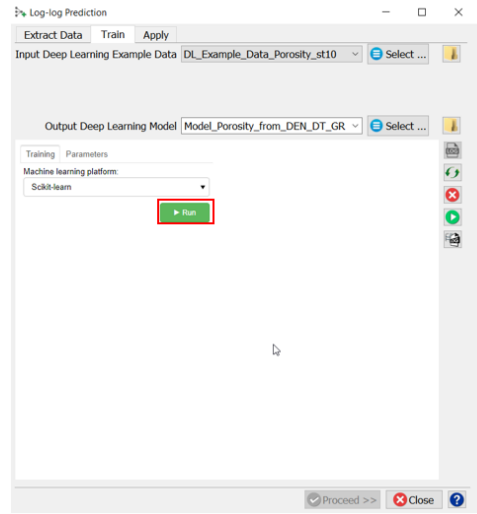

**Workflow cont'd:**

- 20. The 'ML training log' window pops up. When the process finish, **Click** Close.
- 21. In the 'Apply tab' of the Log-log Prediction window, verify all defaults selected data are correct.

The Survey and the Training Model can be modified in this window.

- 22. **Press** Proceed.

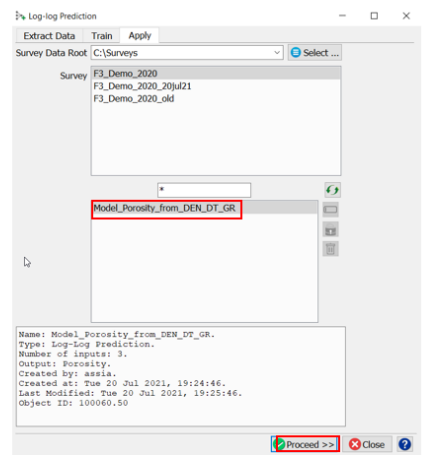
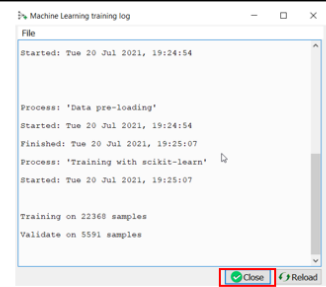

**Workflow cont'd:**

- 23. The 'Apply' created training model window pops up.
- 24. **Apply** the trained model to a blind well (not used in the training process). **Select** F02-1.
- 25. **Keep** default parameters and **Press** Run to continue.
- 26. When the computation finishes, **Press** Close.

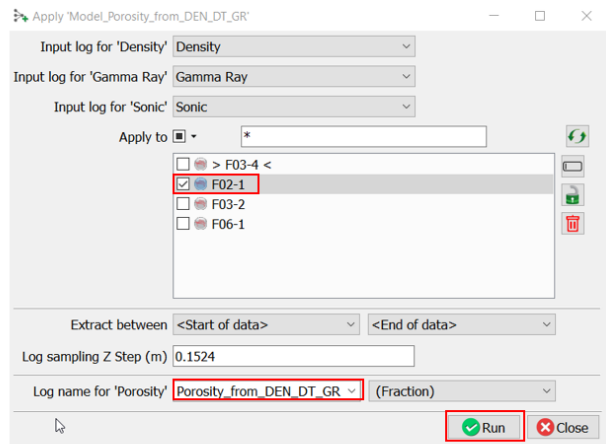

**Workflow cont'd:**

QC results by displaying the predicted log adjacent to the recorded log.

- 27. **Click** on the Well Manager  icon.
- 28. **Select** the well F02-1, and the logs Porosity and predicted porosity: Porosity-from\_DEN\_DT\_GR.
- 29. **Click** on view logs.

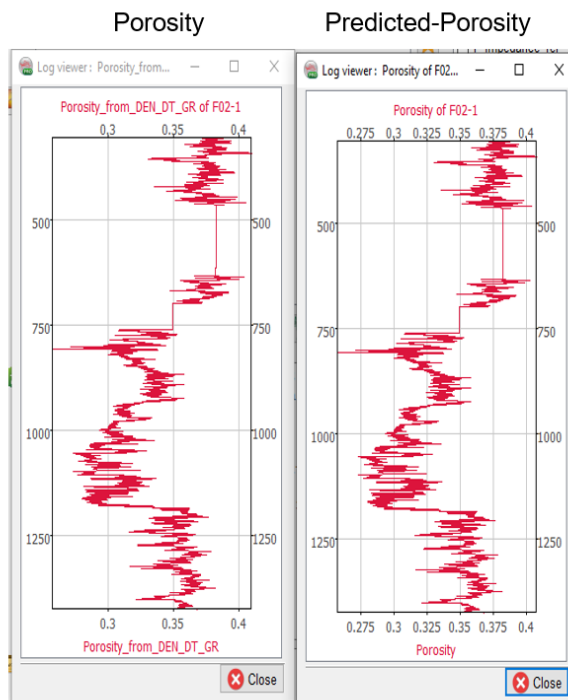
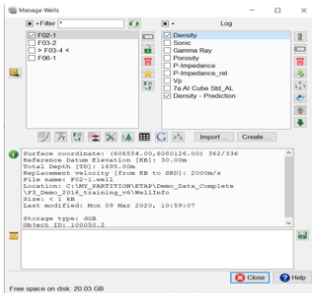



### Workflow cont'd:

If result is satisfactory, go back to the previous Step "Apply Training Model".

30. **Select** all wells where you want to predict porosity.
31. **Keep** default parameters and **Press** Run to continue.
32. **QC** the predicted well porosity logs as in the previous step.

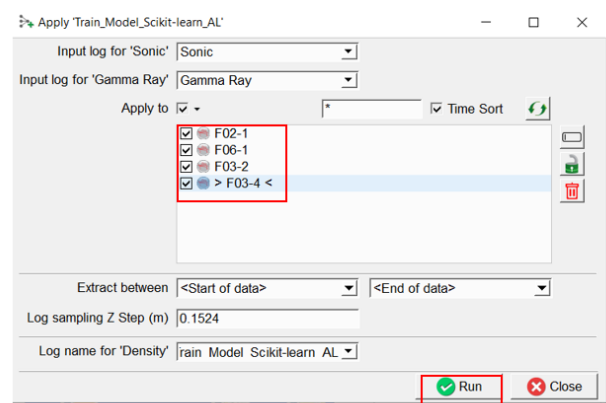

## 2.6.2 Lithology Classification

Required licenses: OpendTect Pro & Machine Learning

### Exercise objective:

To predict lithology logs using the “Lithology classification tool”, which is part of the machine learning plugin.

### Well data Preparation

**Well(s)** need to be available in the survey. If not, **import** wells (track, logs, markers, optionally time-depth curve or checkshot).

### Workflow:

For the purpose of this exercise, we will create a fake lithology log using Mathematics (as no lithology log exists in the survey)

1. **Open** the Well Manager .
2. **Select** All Wells in the “Well Manager”, and **Hit Create**.

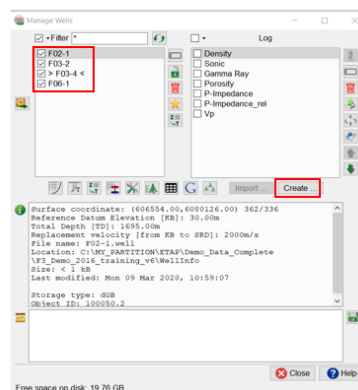

### Workflow cont'd:

3. In the “Calculate a New Well Log” window, **Specify** the parameters as indicated below to create a fake litho-log:

- a. **Select:** MathFunctions.
  - b. **Type** the Formula:  $GR < 40 ? 1 : 2$
  - c. **Hit** Set.
  - d. **Select** Gamma Ray log.
  - e. **Select** for the *Formula Results, Classification*
  - f. **Type** Name for new log: Litho\_Fake.
  - g. **Select** Output Unit of Measures: None.
4. **Press** Calculate.

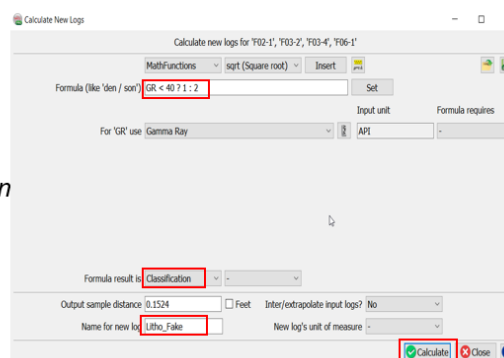

**Workflow cont'd:**

5. **Open** the Machine Learning Control Center with the  icon.
6. **Click** on Wells.
7. **Select** *Lithology classification*.
8. **Hit** Go.

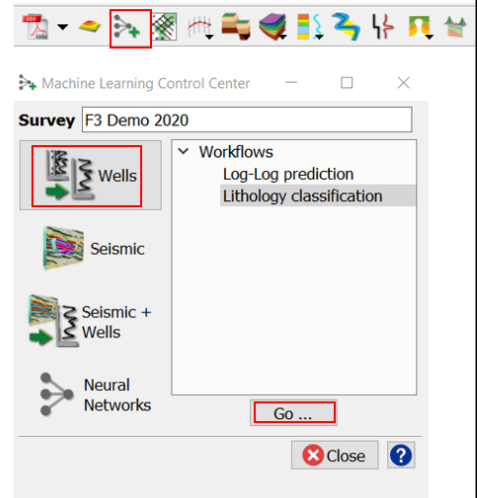

**Workflow cont'd:**

9. "Lithology Classification" window pops up. **Press** Select - Input Data. **Select**  icon in the "Target Log Definition".
10. "Log Data to predict" window pops up. **Select:** Survey\*, Target Log, and Wells as indicated in the window. *In this case the "Litho\_Fake" log will be predicted.*

The well F02-1 is not selected, and will be used as a blind well.

11. **Press** OK.

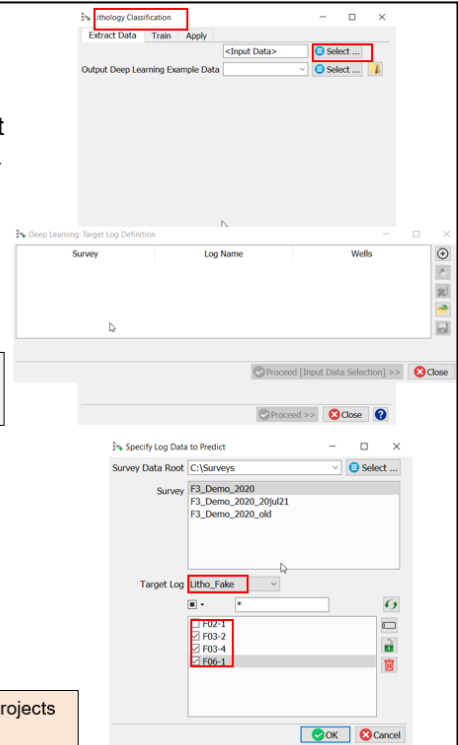

\* The option to select data from other surveys is available only in commercial projects (not in the free demo project)

**Workflow cont'd:**

11. “Deep Learning: Target Log definition” window pops up.
12. **Press** Proceed [Input Data Selection].
13. In the “Select Input Logs” window, **Select** the Density, Sonic and Gamma Ray logs.
14. **Press** OK.

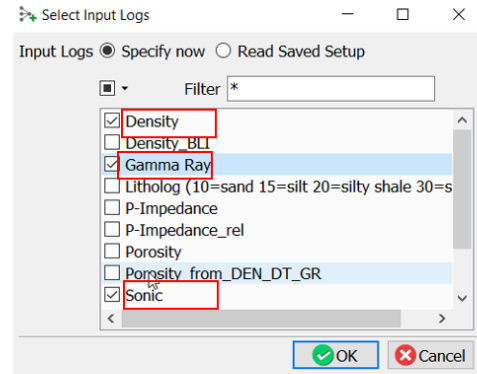
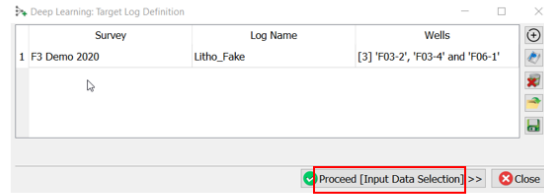

**Workflow cont'd:**

15. “Input Log Selection” window pops up.

Input Logs can be modified here. Keep the default parameters as indicated in the window.

16. **Specify** a new name for the “Output Deep Learning Example Data” (e.g. DL\_Example\_Data\_Lithology\_st10).

17. **Press** Proceed.

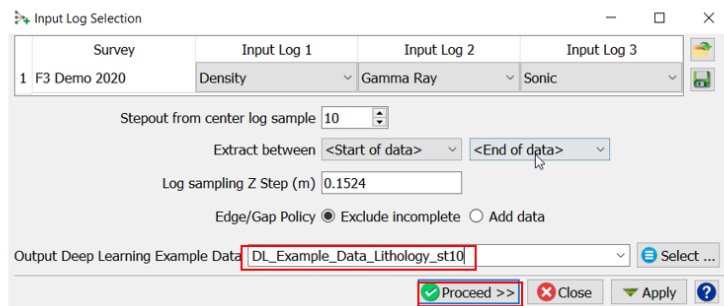

**Workflow cont'd:**

- 18. **Select** Training Type New.
- 19. “Train” tab becomes active. Train the extracted examples using the default learning algorithm (e.g. Keras (tensorflow)).

Different machine learning platforms and parameters can be tested.

- 20. **Keep** the defaults parameters. **Specify** a new *Output model* name (Model\_Litho\_Keras(tensorflow)).
- 21. **Press** Run.

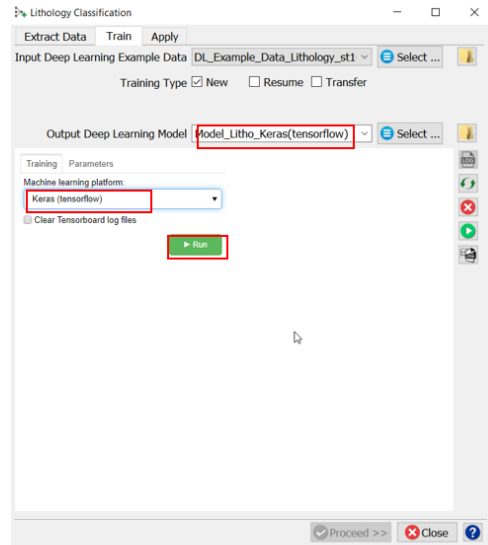

**Workflow cont'd:**

- 22. The Machine Learning training log file pops up. Otherwise **Click** on  icon.
- 23. **Hit** Reload to refresh the window.
- 24. When the processing is done, **Close** the training log file.

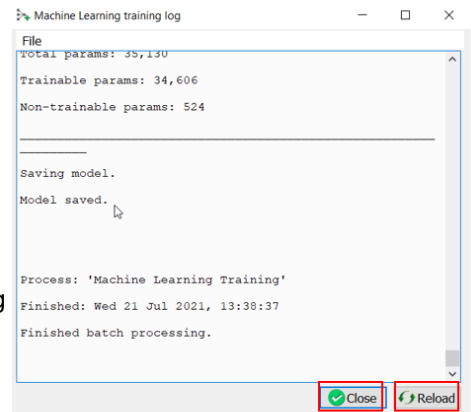

**Workflow cont'd:**

- 25. **Hit** Proceed in the 'Lithology Classification-Train' Window.
- 26. "Apply" tab get activated, **Verify** the Survey and Model are correct. Otherwise, modify accordingly.

\*The Survey, Training model can be modified here.

- 27. **Press** Proceed.

\* The option to select data from other surveys is available only in commercial projects (not in the free demo projects)

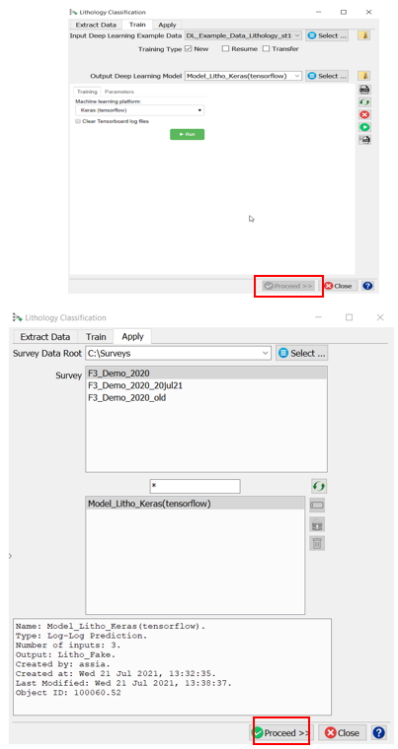

**Workflow cont'd:**

- 28. "Apply created training model" window pops up.
- 29. **Apply** the trained model to a blind well (not used in the training process). **Select** F02-1.
- 30. **Keep** default parameters. **Type** a new Log name for the predicted lithology log "Litho\_Fake\_Predicted".
- 31. **Press** Run to continue.

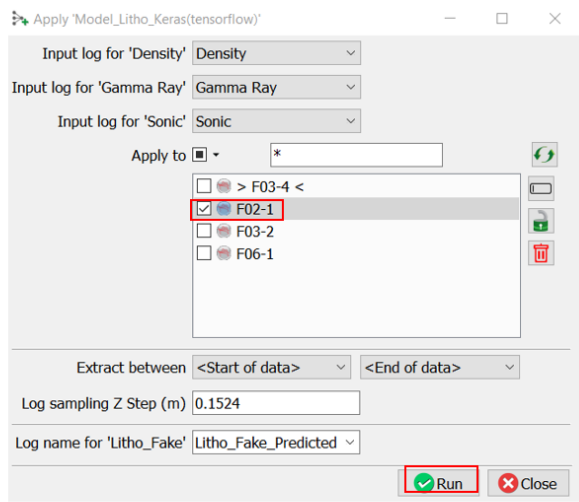

**Workflow cont'd:**

QC results by displaying the predicted log adjacent to the recorded log

- 32. **Click** on the Well Manager  icon.
- 33. **Select** the blind well F02-1, Litho\_Fake and Litho\_Fake\_Predicted logs.
- 34. **Click** on view logs.

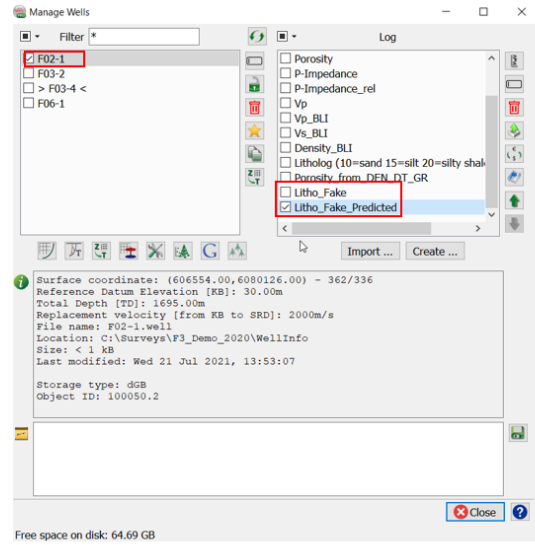

**Workflow cont'd:**

- 35. **Compare** the original vs predicted litho-log.

*Note: The missing parts at the top and base of the predicted log are due to missing values in the input logs.*

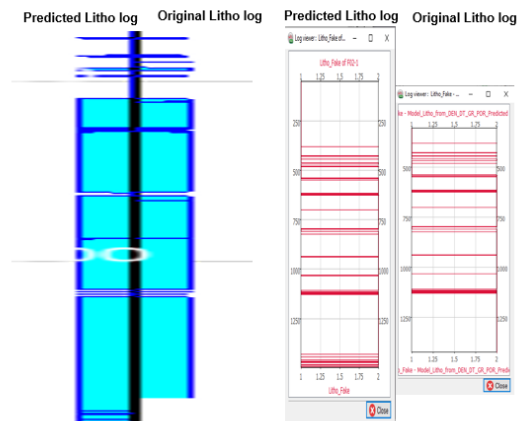
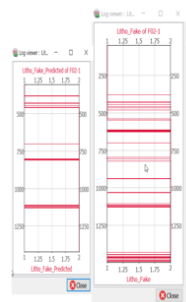

**Workflow cont'd:**

If result is satisfactory, go back to the previous step and Apply the trained model to all Wells

- 36. **Select** All Wells. Keep default parameters as indicated in the window.
- 37. **Press** Run to continue.

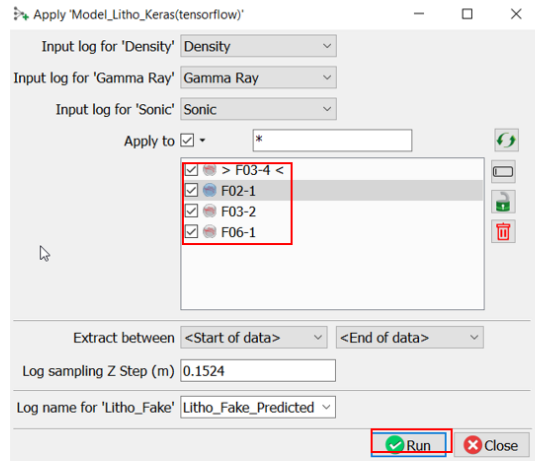



## 2.6.3 Seismic Bodies - Supervised 3D

Required licenses: OpendTect Pro & Machine Learning

### Exercise objective:

To predict seismic geo-bodies using the “*Seismic bodies (supervised 3D)*” tool which is part of the machine learning plugin. In this exercise, we want to predict Chimney location.

### Seismic data Preparation

**Seismic** need to be available in the survey. If not, **import** seismic, and interpret key seismic bodies locations (e.g. Chimney yes, Chimney no), or use existing trained model.

### Workflow:

1. **Open** the Machine Learning Control Center with the  icon.
2. **Click** on Seismic.
3. **Select** Seismic bodies (supervised 3D), and **Hit** Go.

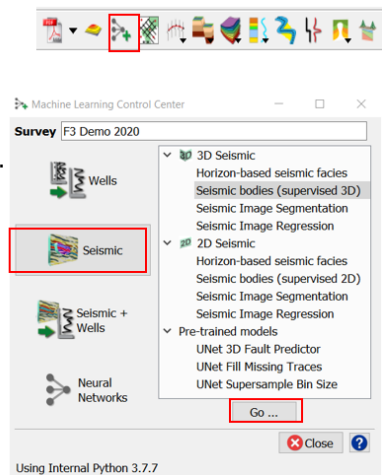

### Workflow cont'd:

4. “*Seismic Classification*” window pops up. **Select** *Input Data* in the “*Extract Data*” tab.
5. In the “*Class Definition*” window. **Select**  icon in to “*Add Class Definition*”.
6. In the “*Select PointSet*” window, **Select** the *Survey* and the 1<sup>st</sup> *Class Example Locations* (e.g. *Chimney* yes).
7. **Press** OK in the “*Specify Class Example Locations*” window.

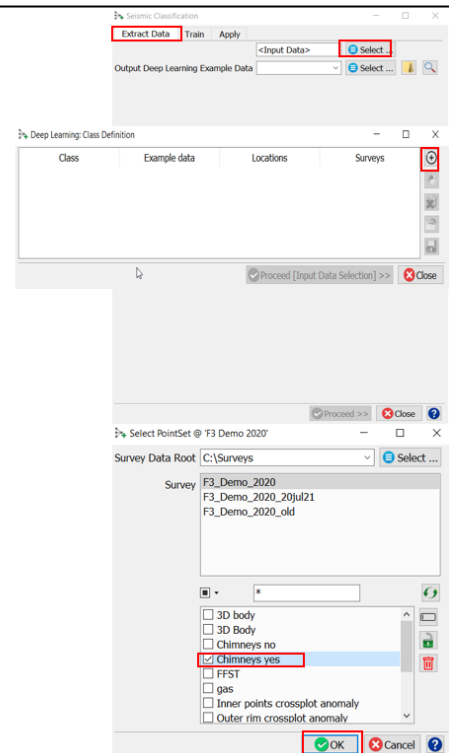
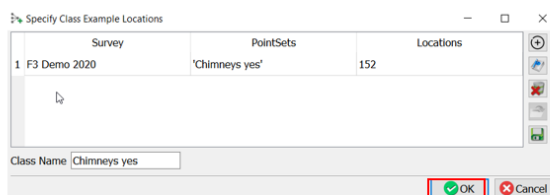

**Workflow cont'd:**

8. In the “Deep Learning: Class Definition” Window, **Hit** icon  to add more PointSet.
9. In the “Specify PointSet” window, **Select** the Survey and the 2<sup>nd</sup> class example locations (e.g. Chimney no).
10. **Press** OK in the “Specify Class Example Locations” window.

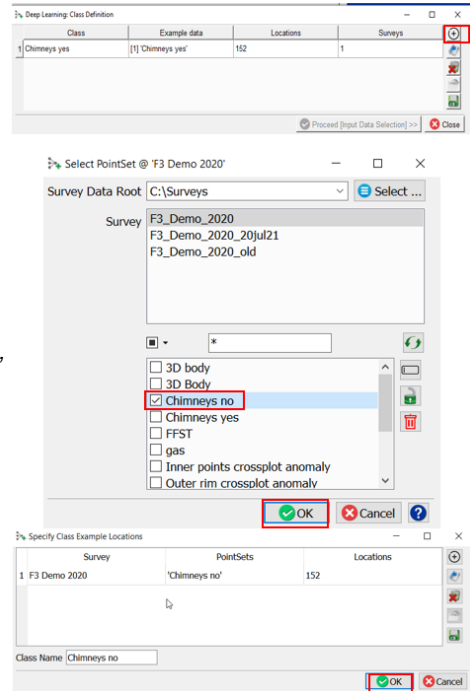

**Workflow cont'd:**

11. In the “Deep Learning: Class Definition” window, **Verify** that the default selected data are correct. **Press** Proceed [Input Data Selection].
12. In the “Input Seismic for prediction” window, **Select** the appropriate 3D seismic cubes, and seismic attributes.
13. **Press** OK.

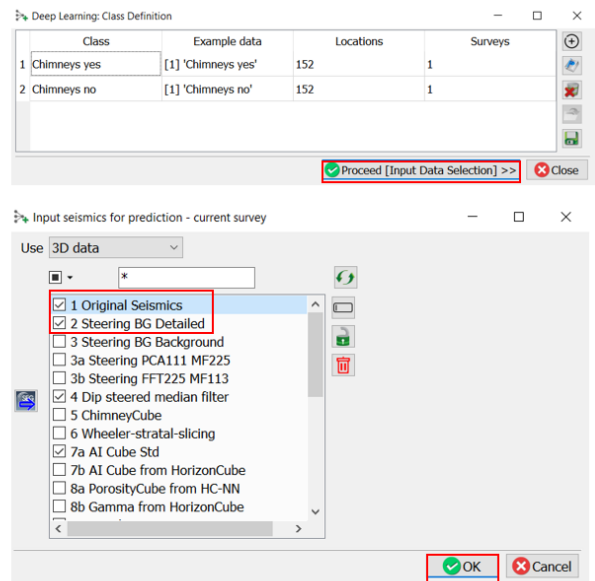

**Workflow cont'd:**

14. "Input Data" window pops up.

Input cubes can be modified. Keep the default parameters as indicated in this window.

15. **Specify** a new name for the *Output Deep Learning Example Data* (e.g. *DL\_Example\_Chimney\_st8x8x16Z4*).

16. **Press** Proceed.

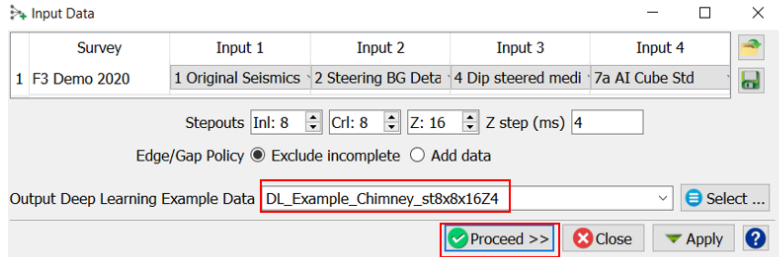

**Workflow cont'd:**

17. *Train* tab opens-up. Select one of the learning algorithm (e.g. Keras-tensorflow) to train the extracted examples data.

Different machine learning platforms and parameters can be tested. Keep the defaults parameters.

18. **Specify** a new *Output model* name (e.g. *Model\_Keras\_Chimney*).

19. **Press** Run.

20. Once the computation is done, **Close** the ML log window.

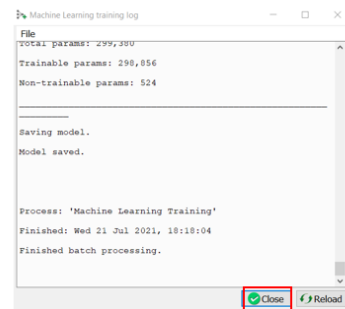
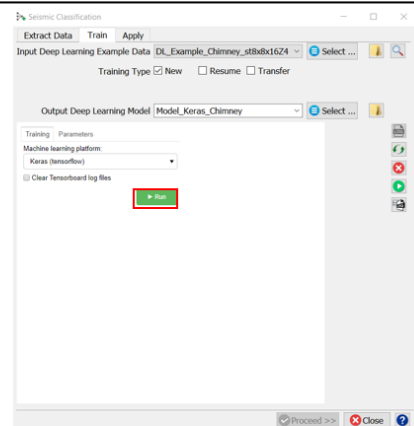

**Workflow cont'd:**

21. **Select** the "Apply" tab. Check all selected data Ok.

\*The Survey, Training model can be modified here if necessary.

22. **Press** Proceed.

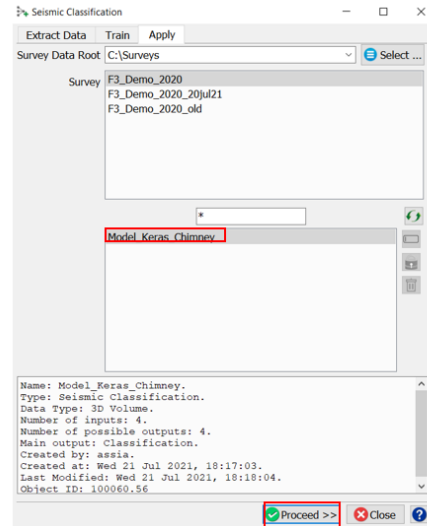

\* The option to select data from other surveys is available only in commercial projects

**Workflow cont'd:**

23. In the "Apply created training model" window, **Verify**, all the default selected input 3D cubes are correct.
  - a. To optimize computation time, **Modify** "Volume sub-selection" and set it to an area of interest, where Chimneys have been interpreted (e.g. Inline range: 670-710, Crossline range: 300-1250).
  - b. **Specify** a new name for the 3D output cubes: Classification, Chimney yes, Chimney no, and Confidence.

24. **Press** Run to continue.

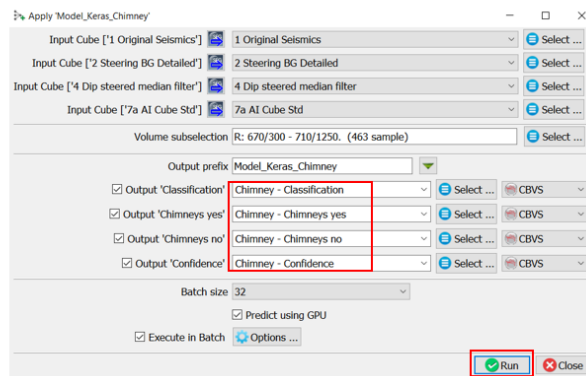
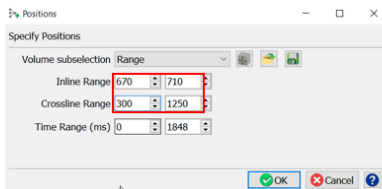

**Workflow cont'd:**

25. When the processing is done, **Close** the "Progress Viewer" and the "Apply Model" windows.

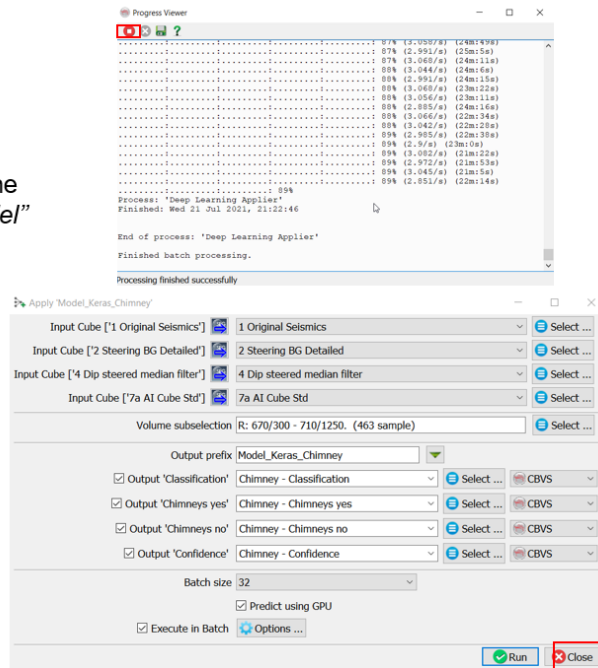

**Workflow cont'd:**

QC results: display the predicted Chimney Yes probability 3D cube

26. **Right Click** on the: Scene > Inline > Add and select Data.
27. **Select** the predicted 3D Chimney location probability (e.g. Chimney\_yes), and overlay the seismic (e.g. 1 Original Seismic).

Modify the Inline number to be within the input range.

28. **Right-click** on the Inline number, and **Type** in the Inline field:  .

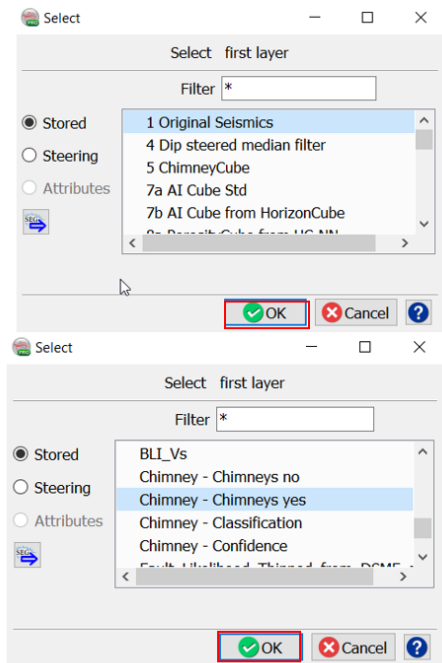

**Workflow cont'd:**

QC results: display the predicted Chimney and overlay the original seismic on in-line 690.

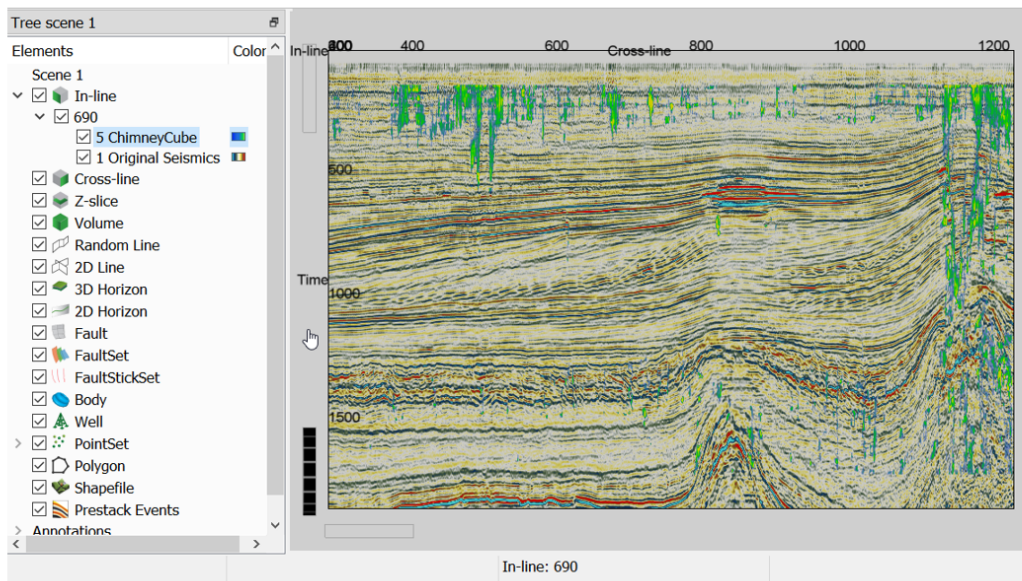

## 2.6.4 Seismic Unet 3D Fault Predictor

Required licenses: OpendTect Pro & Machine Learning

### Exercise objective:

To predict fault's location using the "Seismic – Pre-trained models - Unet 3D Fault Predictor" tool which is part of the machine learning plugin. In this exercise, we want to predict faults location.

### Seismic data Preparation

**Seismic** need to be available in the survey. If not, **import** seismic, and interpret some "key fault" locations or use an existing trained model.

### Workflow:

1. **Open** the Machine Learning Control Center with the  icon.
2. **Click** on Seismic.
3. **Select** the "Pre-trained models – Unet 3D Fault Predictor" and **Hit** Go.

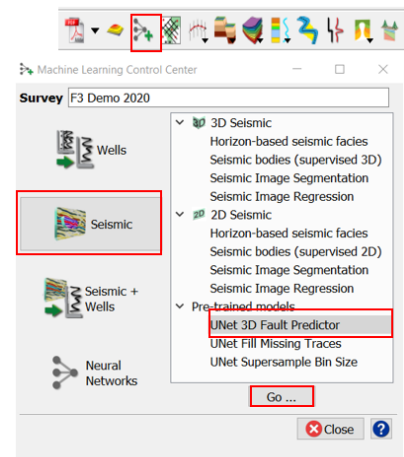

### Workflow cont'd:

4. "Apply Unet 3D Fault Predictor" window pops up.
5. **Select** Input Cube (e.g. 4 Dip steered median filter). Use a volume subselection to optimize the processing time.
6. **Specify** a new name for the "Output Fault Volume to Cube" (e.g. Fault\_Prob\_Unet).

Try running the prediction without the GPU, if it fails, as a result of lack of memory.

7. **Hit** Run.
8. When the processing finish, **Press** button  to close the Progress Viewer window.

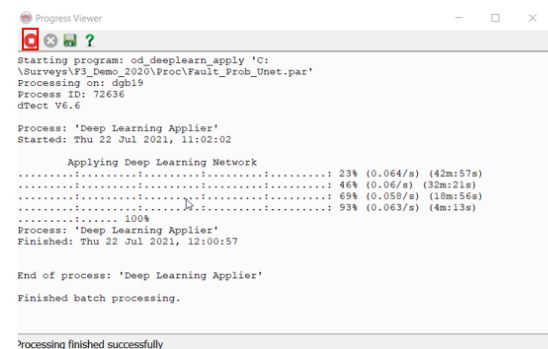
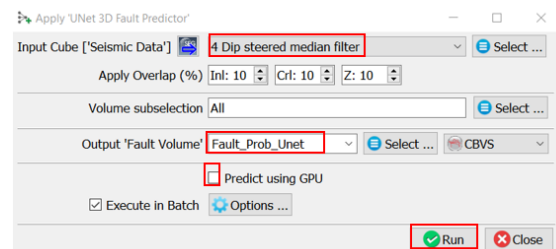

**Workflow cont'd:**

QC the output fault probability results on the In-line 680.

9. **Right Mouse click** on In-line > Add and select Data > Store. **Select** the created Fault Probability cube (e.g. Fault\_Prob\_Unet\_In680), and **Hit** OK.

10. **Type** in the Inline field: 680, and **Hit** Enter.

The same way, add to the display, the existing Thinned likelihood probability display.

11. **Right-Click** on Inline 680 > Add > Attribute > Stored. **Select** the existing thinned fault likelihood (e.g. Fault\_Likelihood\_Thinned\_from\_DSMF\_seis), and **Hit** OK.

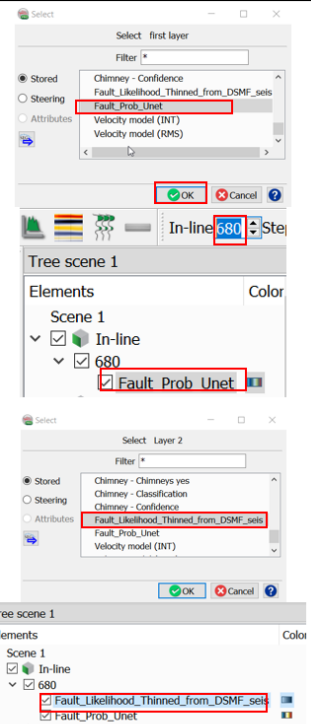

**Workflow cont'd:**

12. **Display** the predicted fault probability, and **Compare** with the thinned fault likelihood.

Note:

The thinned fault likelihood, contains more small faults and noise. Whereas the predicted fault probability, contains more faults information and less noise.

The predicted fault probability is un-thinned. To be able to make a fair comparison with the thinned fault likelihood, a thinning needs to be applied to the predicted fault probability

Predicted fault probability (un-thinned)

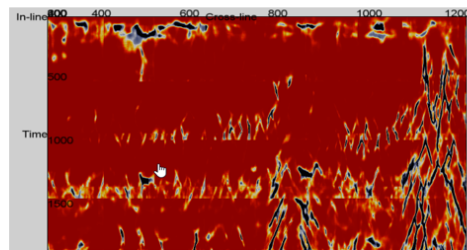

Thinned fault likelihood

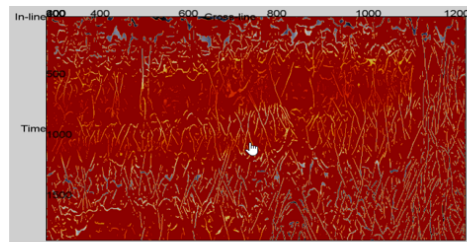



**Workflow cont'd:**

The next step, is to apply a thinning to the predicted fault probability.

13. **Select:** faults and fractures > 3D icon 

14. The Faults and Fractures 3D Control Center window pops up. **Select** Filters > Skeletonization.

15. **Press** Go.

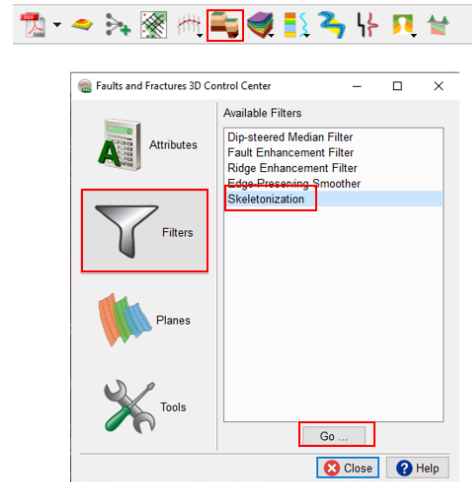

**Workflow cont'd:**

16. The Volume Skeletonization window pops up.

17. **Set** the parameters as specified in the window:  
a. Volume subselection: Inline range = 680  
b. Threshold: 0.5  
c. **Type** a new name for the "Output Cube" e.g. Thinned\_ft\_prob\_Unet\_I680\_threshold"

18. **Hit** Run.

19. The Progress Viewer window pops up. Once the computation is done, **Hit** Close icon .

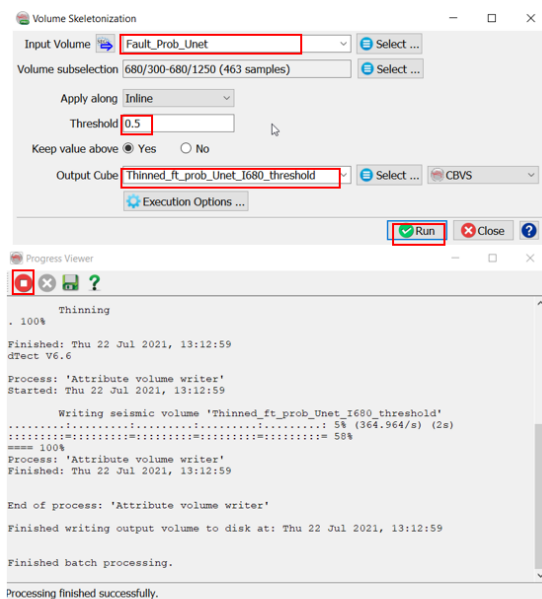

**Workflow cont'd:**

**20. Display:** the new thinned predicted fault probability. **Right mouse click** on the Inline 680 > Add > Attributes. **Select** the new thinned predicted fault probability (e.g. Thinned\_ft\_prob\_Unet\_I680\_threshold). Please make note the name should not contains characters like '.'

**21. Compare** with the existing thinned fault likelihood.

*Notice that the thinned fault likelihood, contains more small faults and noise, whereas the thinned predicted fault probability, output more faults information and less noise.*

Thinned predicted fault probability

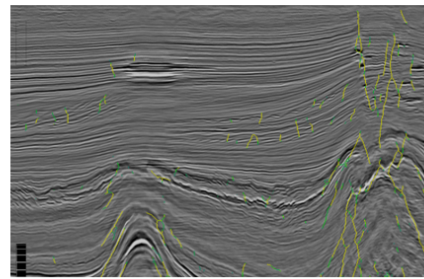

Thinned fault likelihood

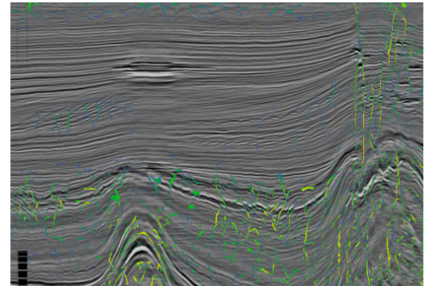

## 2.6.5 3D Seismic and Wells RockProperty Prediction

Required licenses: OpendTect Pro & Machine Learning

### Exercise objective:

To predict rock property using the *3D Seismic + Wells, Rock Property Prediction* tool which is part of the Machine Learning plugin. In this exercise, we want to predict a Porosity cube.

### Well data Preparation

**Seismic** (and/or attributes) and **Well(s)** need to be available in the survey. If not, **import** seismic and wells (track, logs, markers, time-depth curve or checkshot).

### Workflow:

1. **Open** the Machine Learning Control Center with the  icon.
2. **Click** on Seismic + Wells > 3D Seismic
3. **Select** Rock Property Prediction, and **Hit** Go.

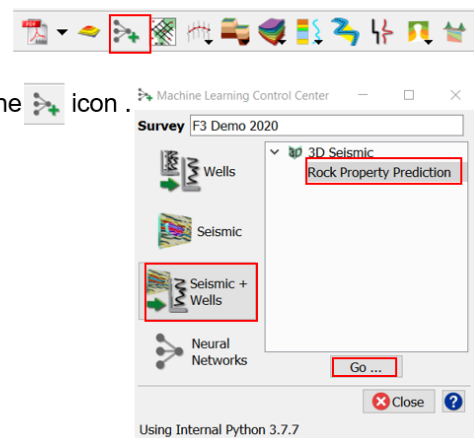

### Workflow cont'd:

4. "Prediction from seismic" window pops up. **Press** Select - Input Data.
5. **Select**  icon in the "Target Log Definition". The "Specify Log Data to predict" window pops up.
6. **Select:** Survey\*, Target Log (e.g. Porosity), and Wells that will be used for the data extraction, as indicated in the window.

The well F02-1 is not selected, and will be used as a blind well.

7. **Press** OK.

\* The option to select data from other surveys is available only in commercial projects

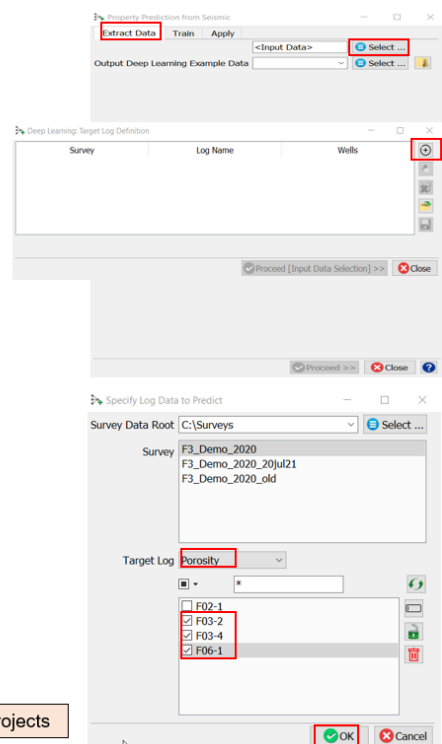

**Workflow cont'd:**

8. Deep Learning: Target Log definition window pops-up.

\*A new data selection from different survey can be added by clicking on 

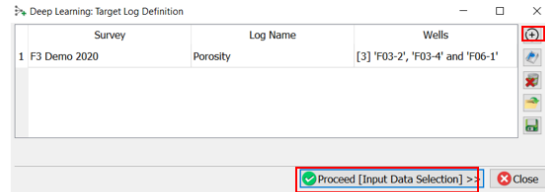

9. In the "Input seismic for prediction" window, **Select** a suitable 3D data to use as input for the training e.g. RMS attribute, Q Factor attribute, Instantaneous phase attribute, Dominant frequency attribute, Seismic volume etc.

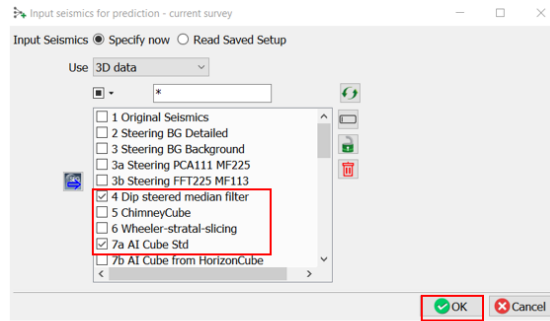

10. **Press** OK.

\* The option to select data from other surveys is available only in commercial projects

**Workflow cont'd:**

11. "The Input Data" window pops up.

Input data can be modified using the drop down selection. Keep the default parameters as indicated in this window.

12. **Specify** a new name for the *Output Deep Learning Example Data* (e.g. *DL\_Example\_Data\_Porosity\_st0x0x16z4*).

13. **Press** Proceed.

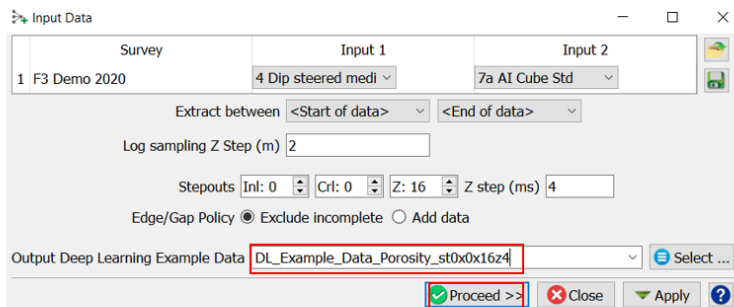

### Workflow cont'd:

- The *Train* tab gets activated. Train the extracted examples data using the default learning algorithm Scikit-learn (Ensemble: Random Forests).

Different machine learning platforms and parameters can be tested. Keep the default parameters for this exercise.

- Specify** a new *Output model* name e.g. Porosity\_Model\_SL\_RandomForests.
- Press** Run.

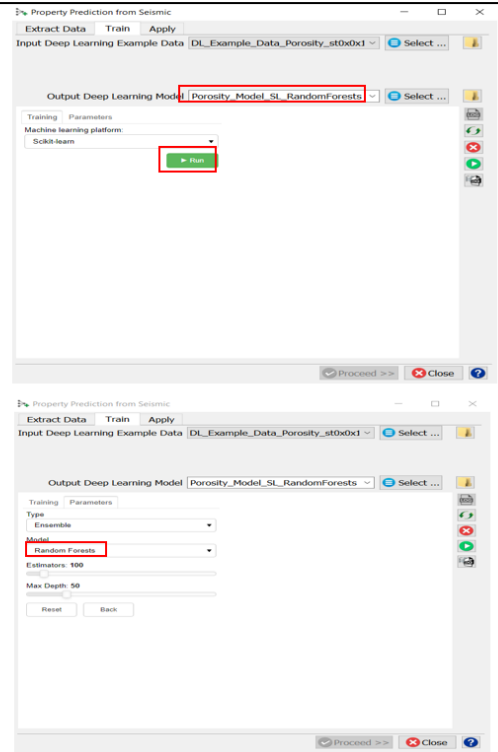

### Workflow cont'd:

- Hit** Close in the "Machine Learning training log" window, when the processing finishes.
- The *Apply* tab get activated. The Survey, Training model can be modified here. Keep the default selection as indicated in the window. **Press** Proceed.

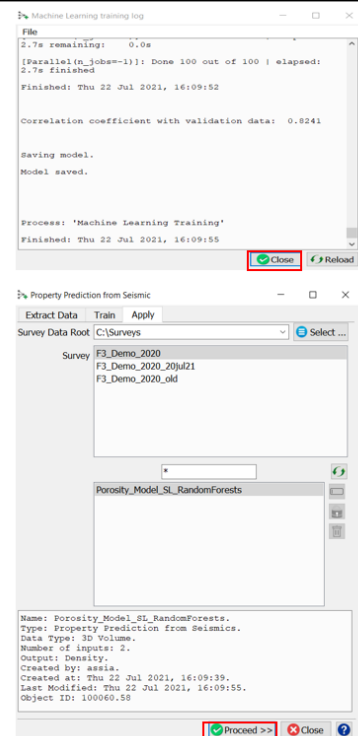

**Workflow cont'd:**

19. The "Apply created training model" window pops up. Apply first the trained model on 1 Inline.
20. In the volume sub-selection, **Select** Inline range 362. Choose an Inline crossing a well with porosity log e.g. F02-1.
21. **Hit** OK.
22. In the "Apply the trained model", Keep default parameters, **Specify** a new name for the output porosity to cube (e.g. Porosity\_Predicted\_ML\_RandomForests).
23. **Press** Run to continue.

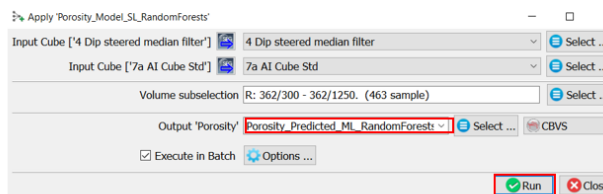
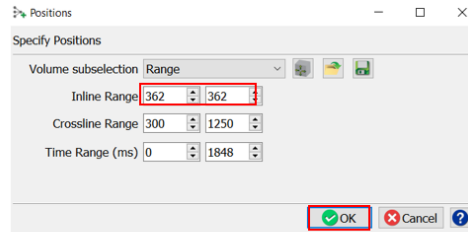
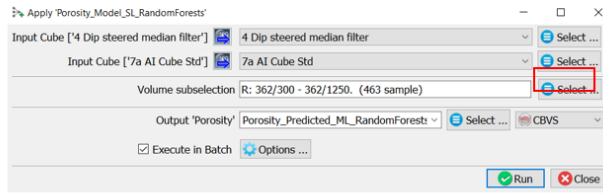

**Workflow cont'd:**

When the computation finishes, close the Progress viewer window.

QC results by displaying the predicted Porosity on the test Inline (e.g. 362) and overlay the crossing well F02-1, with the porosity log.

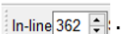
24. **Right Mouse Click** on the Inline folder > Add Default Data e.g. Deep Steered Median Filter. Type: 362 in the In-line field Change the In-line no to 362 .
25. **Right Mouse Click** on the In-line 362 > Add > Attributes. **Select** under Stored the new predicted porosity (e.g. Porosity\_Predicted\_ML\_RandomForests), and **Hit** OK.
26. **Modify** the Porosity colour limit to (0.25-0.35)

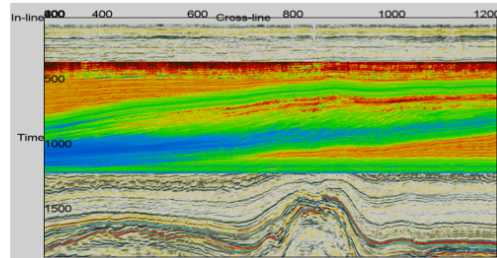
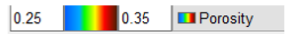
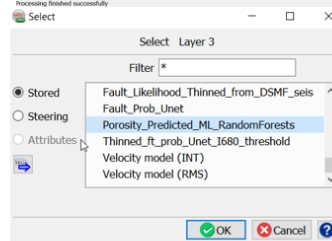
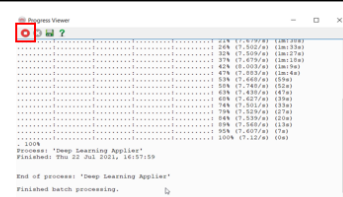

**Workflow cont'd:**

27. **Right Mouse Click** on the well folder > Add, **Select** the well F02-1, **Hit** Ok.
28. **Right Mouse Click** on the Well F02-1 > Display > Properties, **Select** Porosity log, **Change** the color bar to Porosity. **Modify** the Porosity color range similar to the predicted porosity cube range (0.25 - 0.35).
29. **Apply** to All Wells, and Hit Close.

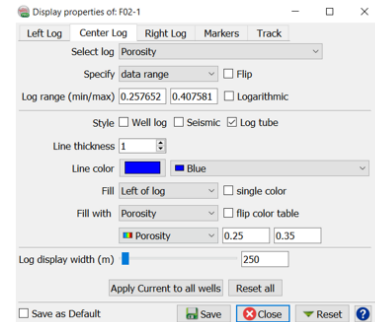
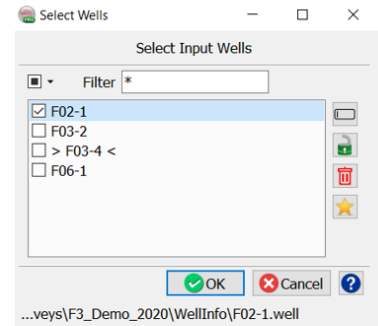
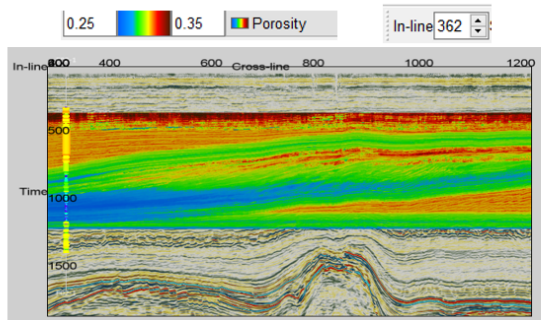

**Workflow cont'd:**

If result is satisfactory, go back to the previous Step and **Apply** the trained model to the entire survey.

30. **Go back** to the Apply tab > Volume sub-selection > In-line range and reset of the entire range.
31. **Keep** all other default parameters and **Press** Run to continue.

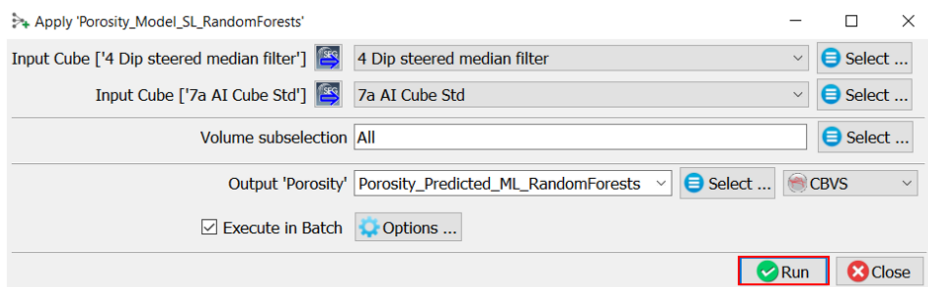
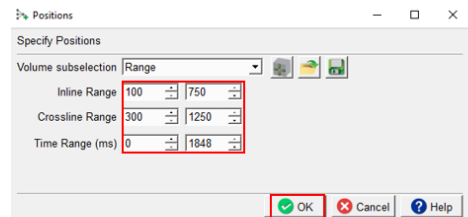

## 2.6.6 Seismic Image to Image - Fault Prediction

Required licenses: OpendTect Pro & Machine Learning

### Exercise objective:

To predict seismic features using the *Seismic Image to Image* workflow in the machine learning plugin. In this exercise, we will predict fault locations from seismic data.

### Warning 1: To predict real faults use the pre-trained U-Net fault predictor

In this exercise we train a U-Net to predict faults from pre-processed seismic input. The input is Edge-Preserved Smoothed (EPS) seismic data. The target is a mask volume with ones (faults) and zeros (no-faults) that was created from Thinned Fault Likelihood (TFL) computed from the EPS volume. **Note** that from a geoscience perspective this is not a meaningful exercise because we do not need a machine learning model to predict a desired outcome that can be computed directly with an algorithm. The main purpose of this exercise is to learn how to run image-to-image workflows.

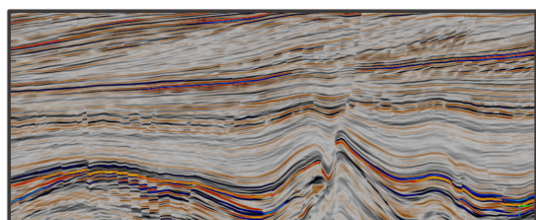

Input EPS\* seismic

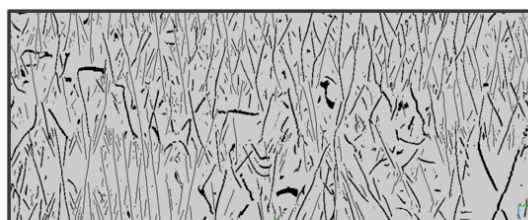

Target mask (0,1) of TFL\* from EPS

\*EPS and TFL-mask are **NOT** delivered with F3. To replicate this workflow first create EPS and TFL (from EPS) in the Faults & Fractures plugin. Next create a mask from TFL with the mathematics attribute using this formula:  $TFL > 0.01 ? 1 : 0$

### Exercise objective:

### Warning 2: heavy GPU requirements

In this exercise we create 1008 cubelets of 128x128x128 samples. These cubelets are extracted from half the input - and target volumes. The trained U-Net is applied to the full volume. Application is very fast (minutes) but training takes several hours on a GPU. The graphics card we used is a Nvidia GeForce RTX 2080 Ti with 11 GB DDR6 memory. In principle the exercise can also be run on a CPU but then training may take several days.

### Workflow:

1. **Open** the *Machine Learning Control Center* with the  icon.
2. **Click** on *Seismic*.
3. **Select** *Seismic Image to Image*, and **Hit Go**.

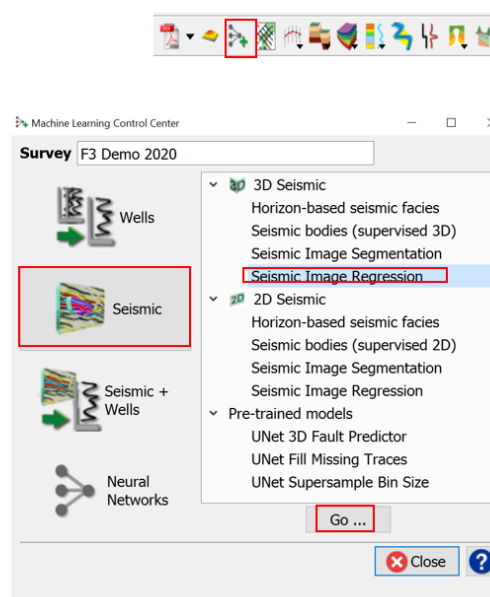



**Workflow cont'd:**

4. *Seismic Image Transformation* window pops up.
5. **Select** *Target Data* in the *Extract Data* tab. **Click** on the target data specification.
6. In the *Select target image seismic* window, **Select** the *Survey* and the target cube *TFL\_from\_EPS\_mask*

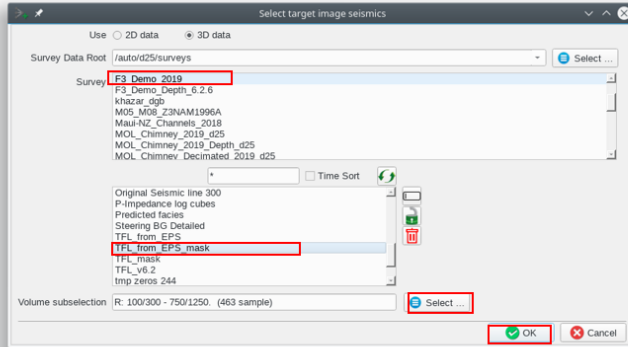
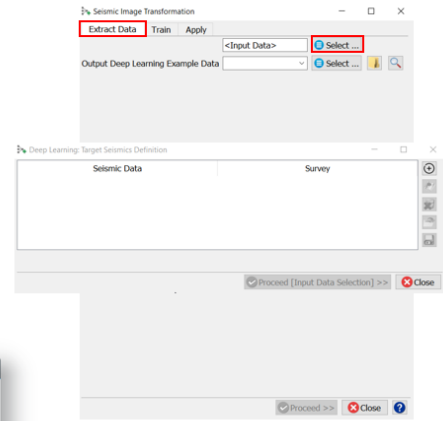

**Workflow cont'd:**

7. The *Deep Learning: Target Seismics Definition* window pops up.
8. **Press** *Proceed [Input Data Selection]*

\*Additional seismic attributes can be added using the  icon . Keep the defaults data.

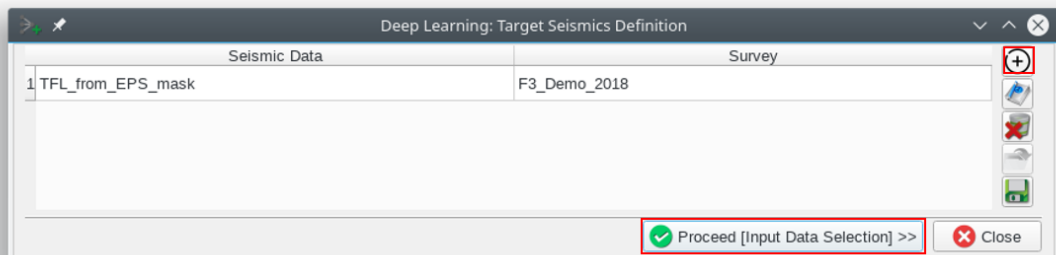

\* The option to select data from other surveys is available only in commercial projects

**Workflow cont'd:**

9. **Select** *Edge Preserved Smoothed* as input seismic to be used for the prediction
10. **Press** OK

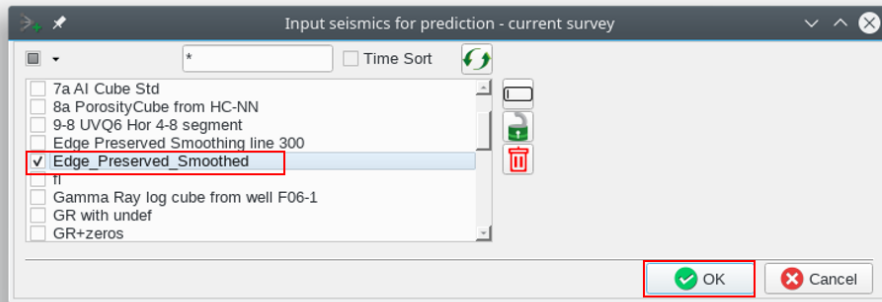

**Workflow cont'd:**

11. In the *Input Data* window **set** the *Image dimensions* of the cubelets to 128 x 128 x 128 samples. Note: to extract 2D images set one of the dimensions to 0.
12. **Specify** the *Inline*, *Crossline*, *Time Ranges* and the corresponding *Overlap\** percentages to such that we extract approx. 1000 cubelets from one half of the input and target volumes (see image for specifications).
13. **Specify** a name for the *Output Deep Learning Example Data* (e.g. *ML\_train\_data\_EPS2TFL\_128x128x128*) and **press** Proceed.

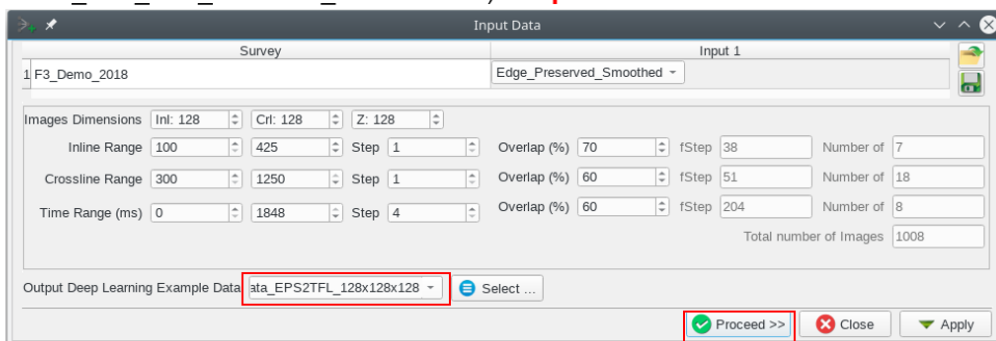

*\*Overlap: if the number of examples that can be extracted from a given range and overlap does not fit exactly, the last example is extracted from the boundary backwards.*

Example cubelets. Dimensions are: 128 x 128 x 128 samples

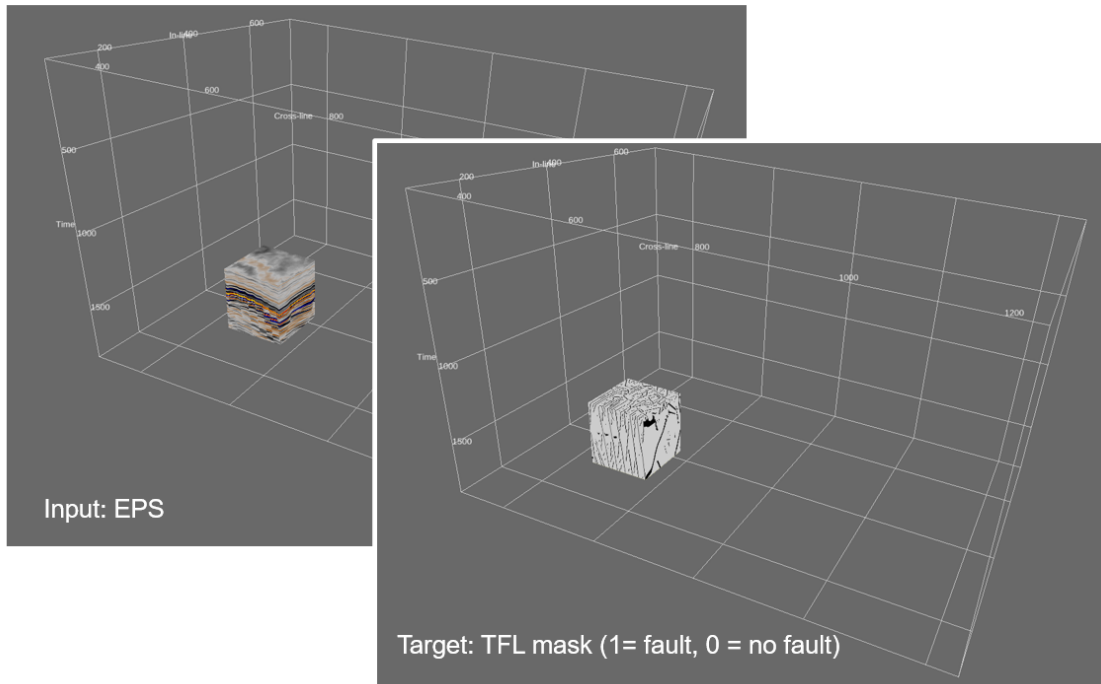

#### Workflow cont'd:

14. Specify the *Output Deep Learning Model* name (e.g. ML\_U-Net\_EPS2TFL\_128x128x128)
15. In the *Train* tab, **Select** Keras (tensorflow) as *Machine learning platform*
16. **Select** the *Parameters* tab

The machine learning plugin supports two platforms: Keras (tensorflow) for deep learning (convolutional neural networks) and Scikit Learn for all sorts of other machine learning models (e.g. Random Forests). Supported models and training parameters are specified in the Parameters tab.

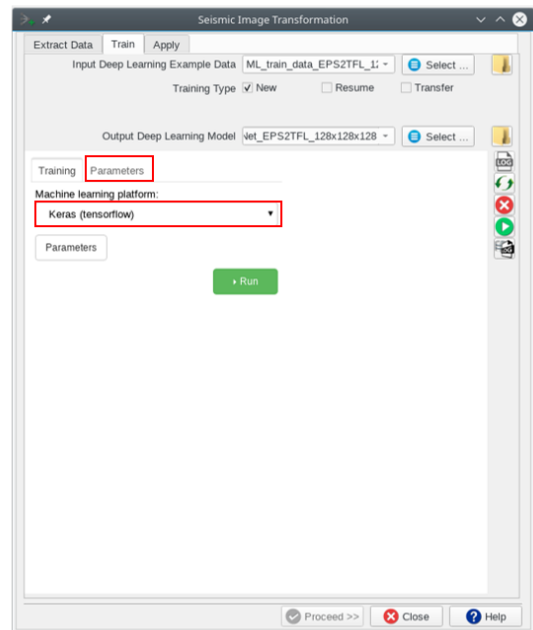

**Workflow cont'd:**

17. In the *Parameters* tab **Select** Type U-Net

18. **Set** Batch Size to 2. A U-Net needs a lot of GPU memory in the training phase. If memory is exceeded, training stops with an error message. You can then try to rerun with a smaller batch size. Try with the largest possible batch size as training performance increases with batch size.

19. **Set** the number of *Epochs* to 100 (this is the number of training cycles through all examples that are offered in batches of Batch Size).

20. **Set** *Patience* to 50. This parameter avoids early stopping when the error does not decrease after this number of Epochs.

21. **Go back** to the *Training* tab.

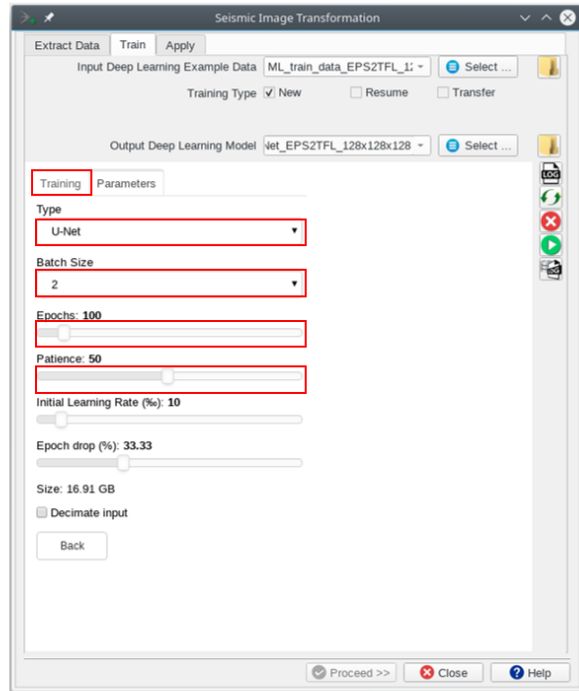

**Workflow cont'd:**

22. In the *Training* tab **Press** Run

23. The Machine Learning training log window pops up. This window can also be started by pressing the  icon. **Press** Reload to refresh.

24. *TensorBoard*, a program to examine models and track training performance is started automatically in a browser.

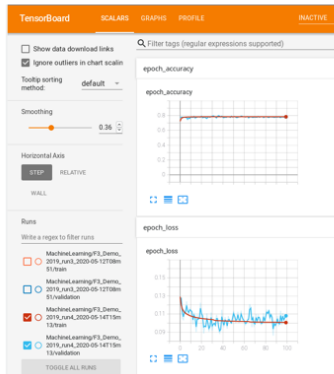
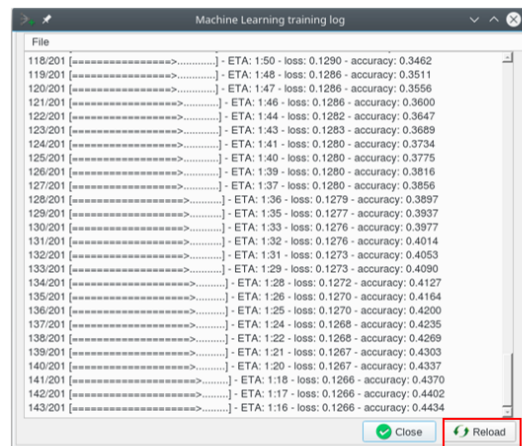

**Workflow cont'd:**

25. When training is finished, **Select** the *Apply* tab

26. **Select** the trained model *ML\_U-Net\_EPS2TFL\_128x128x128* and **Press** *Proceed*.

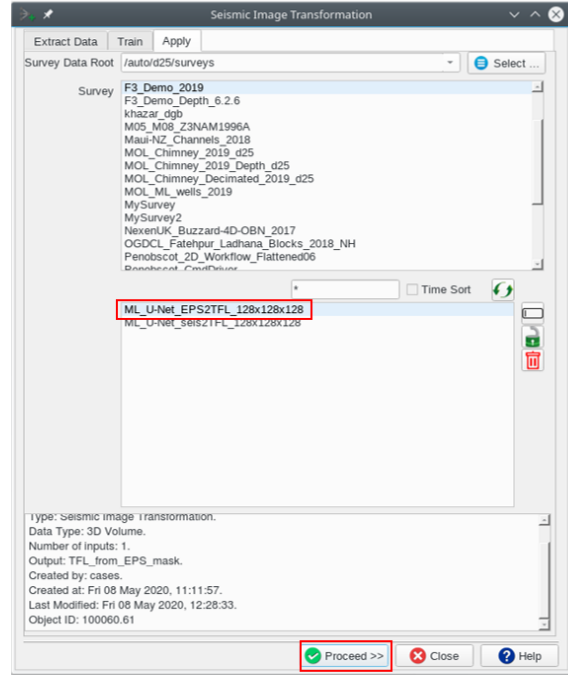

**Workflow cont'd:**

27. In the *Apply* window **Select** the *Input Cube* *Edge\_Preserved\_Smoothed*.

28. Specify the *Output Cube* name that will be created by the trained model, e.g. *ML\_U-Net\_TFL\_prediction*.

29. **Press** *Run* to start processing.

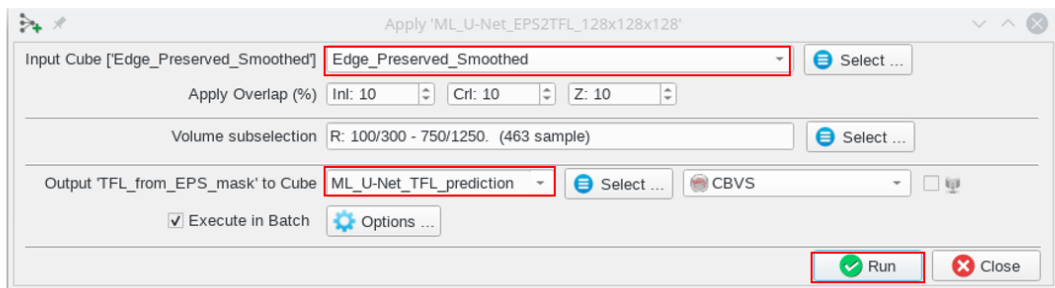

**Workflow cont'd:**

30. A *Progress Viewer* window pops up. Applying the trained U-Net is very fast. The resulting fault prediction can be viewed e.g. as overlay on the EPS of inline 425.

```
Progress Viewer
.....= 884 (39.8957/s) (3m:20s)
.....= 894 (39.974/s) (4m:07s)
.....= 904 (39.928/s) (4m:45s)
.....= 914 (39.977/s) (5m:00s)
.....= 924 (38.209/s) (4m:31s)
.....= 934 (38.037/s) (4m:19s)
.....= 944 (39.885/s) (3m:58s)
.....= 954 (32.626/s) (4m:32s)
.....= 964 (39.888/s) (3m:50s)
.....= 974 (39.657/s) (3m:18s)
.....= 984 (32.601/s) (3m:46s)
.....= 994 (41.071/s) (2m:47s)
.....= 1004 (40.578/s) (2m:37s)
.....= 1014 (36.023/s) (2m:43s)
.....= 1024 (40.634/s) (2m:12s)
.....= 1034 (41.094/s) (1m:58s)
.....= 1044 (36.046/s) (2m:18s)
.....= 1054 (39.882/s) (1m:37s)
.....= 1064 (33.868/s) (1m:39s)
974
Process: 'Deep Learning Applier'
Finished: Mon 06 Apr 2020, 00:07:06

End of process: 'Deep Learning Applier'
Finished batch processing.

Processing finished successfully
```

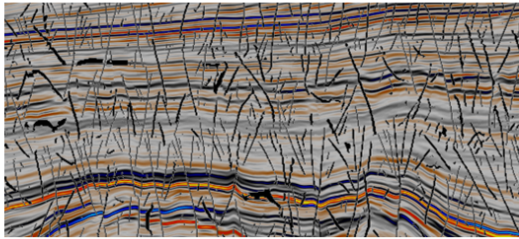

Inline 500 EPS + TFL mask

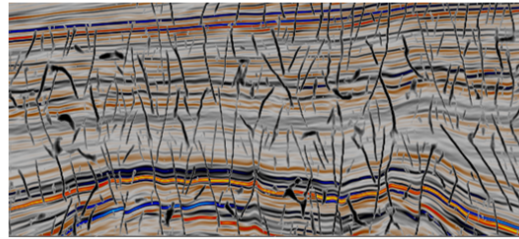

Inline 500 EPS + U-Net Prediction

---

## 2.6.7 Seismic Image Regression (Unet) - Fill Seismic Traces

*Required licenses: OpendTect Pro & Machine Learning*

### Exercise objective:

To fill blank seismic traces using the 'Seismic Image Regression' workflow which is part of the machine learning plugin. The model will have to learn how to recreate an image from example images containing blank traces. Therefore, we need an input data set in which we have deliberately blanked some of the traces.

For the purpose of this exercise:

- We use OpendTect's attribute engine to randomly blank +/- 33% of all traces
- We select examples from one side of the volume for training the U-Net
- We apply the trained U-Net to the full volume, so that we can validate the interpolation results in the blind test zone

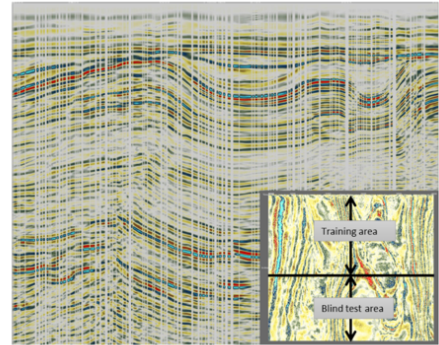

Note: In this exercise we train a 2D Unet but you can equally well train a 3D Unet. The differences between 2D and 3D Unets are as follows:

1. A 2D model trains much faster (hours vs days)
2. 2D models can be trained on workstations with less GPU / CPU capacity
3. Interpolation results are comparable although 2D interpolation may introduce some striping (like a footprint)
4. Application of a trained 3D model is much faster than a trained 2D model (minutes vs hours)



### Randomly blank traces workflow:

To train our 2D Unet regression model we create a data set with 33% randomly blanked traces. From this cube we extract examples for training in a restricted area. The trained model is applied to the entire volume, whereby the area from which no examples are extracted acts as blind test area. The real value is of course when we apply the trained model to an area with real missing traces (which we don't have in this case). Random blanking (replacing the values with hard zeros) is done in OpendTect's Attribute engine and can be done in different ways. In this case, we will create an attribute set to perform the following tasks:

1. Math attribute with formula: "randg(1)". This generates random values with a Gaussian distribution and 1 standard deviation;
2. Apply this attribute to a horizon and save as horizon data;
3. Horizon attribute that retrieves the random values from the saved horizon data. A Horizon attribute replaces a value at an inline, crossline position with the value extracted from the given horizon;
4. Math attribute with formula: "abs(value)> 1 ? 0: seis". We assign the retrieved horizon data to the variable "value" and the seismic data to "seis". This attribute assigns values larger than the absolute value of 1 standard deviation to zero while all other values are given the value of the seismic data.
5. Additional attributes in the set are used to compare/QC results before and after prediction.

### Randomly blank traces workflow:

Create a new 3D attribute set to randomly blank traces as explained in the following steps.

1. **Select** the 3D Attributes engine  icon.
2. **Create** a new 3D attribute set . These attributes that will be explained in the next steps.
3. **Save** as attribute set  with the name 'ML\_Random\_holes\_interpolation'.

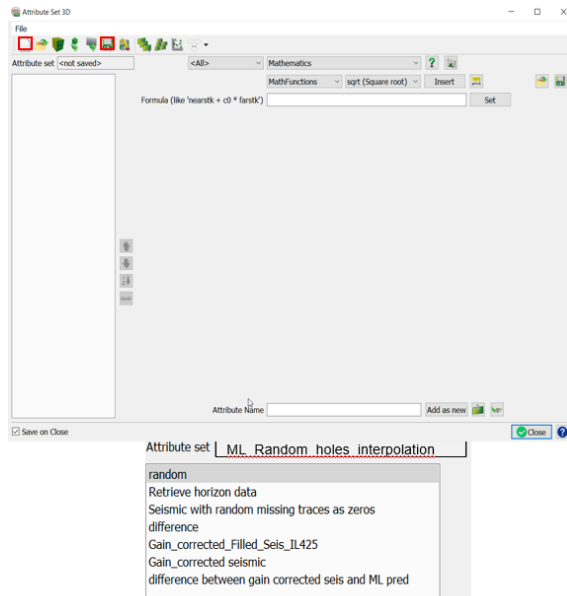

### Randomly blank traces workflow:

4. **Create** 1<sup>st</sup> attribute with name 'random' as indicated in the attribute set window and **Hit** 'Add as new'.
5. **Set** Math attribute with formula: "randg(1)". This generates random values with a Gaussian distribution and 1 standard deviation; Apply this attribute to an horizon and save as horizon data as indicated in the next step.

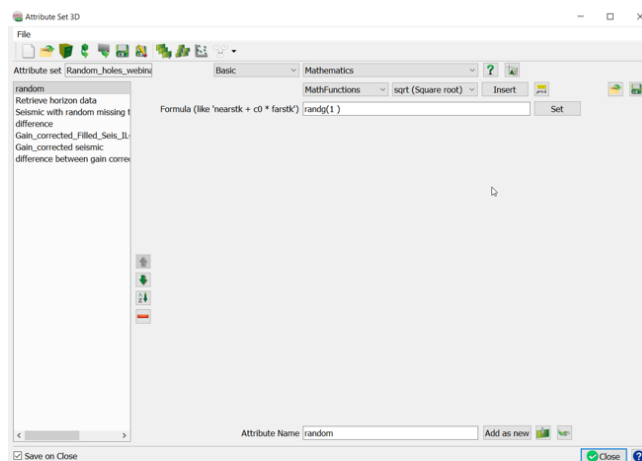



### Randomly blank traces workflow:

Create a seismic horizon at Z = 1 s. Then apply the random attribute to this horizon and save this as horizon data. This horizon data will be used in the attribute that does the actual blanking.

**6. Create** a constant seismic horizon at Z = 1s.

**7. Right mouse click** on the 3D Horizon < New < With constant Z.

**8. Enter** Z value (ms)= 1000. Type an Output 3D Horizon name e.g. Hrz\_1s. **Hit** Create.

**9. Display** the horizon – attribute ‘random’. **Save as** Horizon data.

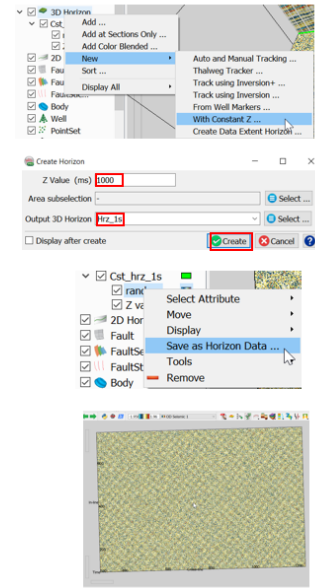

### Randomly blank traces workflow:

Create an horizon attribute that retrieves the random values from the saved horizon data. The horizon attribute replaces a value at an inline, crossline position with the value extracted from the given horizon.

**10. Create** 2<sup>nd</sup> attribute “Retrieve horizon data” as indicated in the attribute set window and **Hit** ‘Add as new’.

**11. Select** the Input Data that will be blanked ‘4 Dip steered Median filter’.

**12. Select** the constant horizon “Hrz\_1s” created in the previous step.

**13. Select** Output “Horizon Data” and Horizon Data “random”.

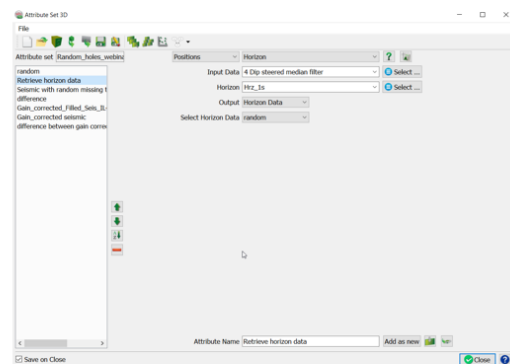

### Randomly blank traces workflow:

Create an attribute that will randomly blank traces as zeros in the input seismic.

**14. Create** 3<sup>rd</sup> attribute 'Seismic with random missing traces as zeros' as indicated in the attribute set window and **Hit** 'Add as new'.

**15. Set** a Math attribute with formula: "abs(value)> 1 ? 0: seis". This assign the retrieved horizon data to the variable "value" and the seismic data to "seis". This attribute assigns values larger than the absolute value of 1 standard deviation to zero while all other values are given the value of the seismic data.

**16. Select** the previously created attribute 'Retrieve Horizon Data' in the 'For Horizon to use'.

**17. Select** the seismic you wish to blank in the 'seis' (e.g. 4\_Dip steered median filter).

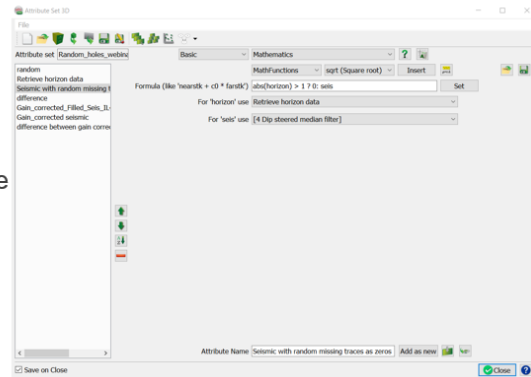

### Blank traces workflow cont'd:

18. Display the new seismic attribute with blanked traces. **Right mouse click** on the In-line. **Select** 'Add and Select Data'

19. **Select** the attribute "Seismic with random missing traces as zeros" and **Hit** Ok.

Notice that random traces have been blanked.

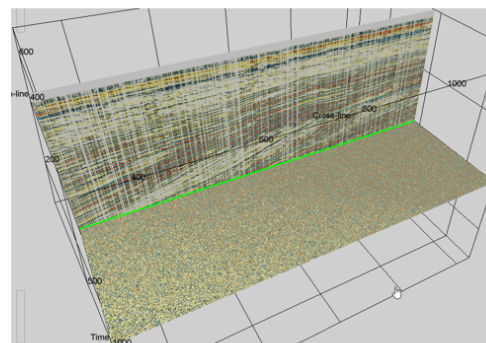
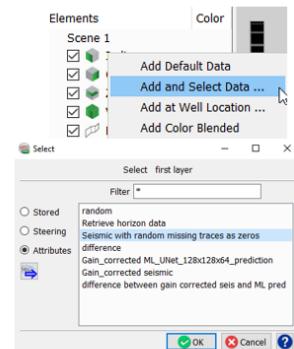

### Blank traces workflow cont'd :

20. **Select**, "Create a Seismic Output" from the attribute – Seismic with random missing traces as zeros.

21. In the "Create Single Attribute Volume" window, keep the default parameters. **Type** an Output name (e.g. Seismic with random missing traces as zeros) and **Run**.

22. **Close** the progress window when the processing finish

23. **Display**/QC the created seismic

This seismic will be used as input for the next step, ML Seismic Image Regression prediction.

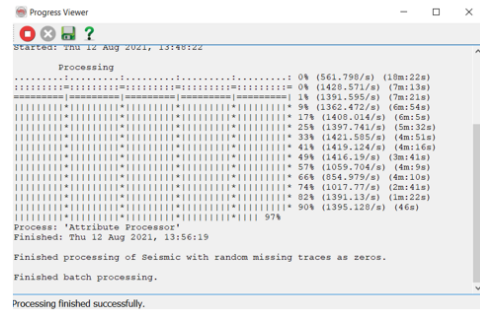
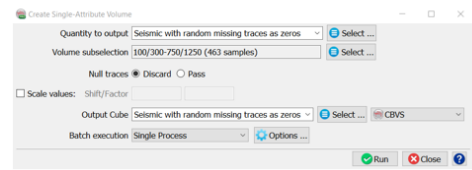
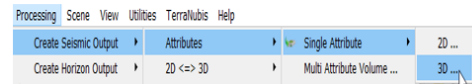

### Exercise objective:

To fill blank seismic traces using the 'Seismic Image Regression' tool which is part of the machine learning plugin. The model will have to learn how to recreate an image from example images containing blank traces.

### Workflow:

1. **Open** the Machine Learning Control Center with the icon.
2. **Click** on Seismic.
3. **Select** the 'Seismic Image Regression' and **Hit** Go.

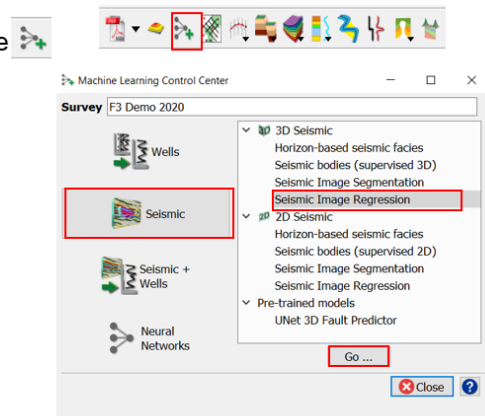

**Workflow cont'd:**

4. In the 'Extract Data' tab, **Press** the Select button. The "Deep Learning Target Seismic Definition" window pops up.

5. **Press** the + icon and **Select** the target seismic volume (e.g.4 Dip steered median filter). **And OK.**

**\*Note:** it is possible to create a Training Set from examples extracted from multiple surveys. To do this, press the + icon again and select the target volume to add to the table below.

6. **Press Proceed [Input Data Selection].** The "Input seismic for prediction" window pops up

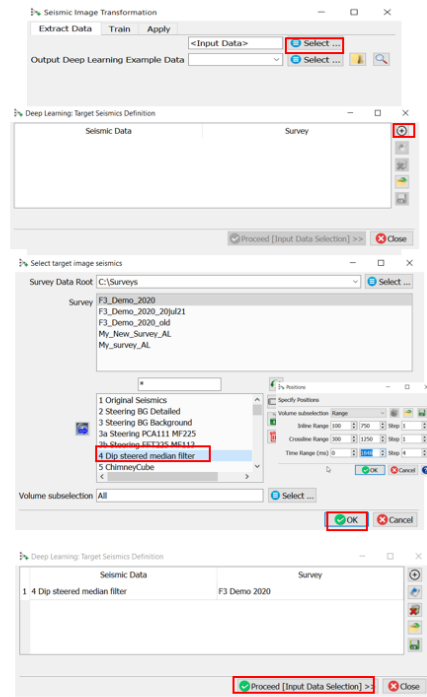

\* The option to select data from other surveys is available only in commercial projects

**Workflow cont'd:**

7. **Select** the input seismic data (i.e. the seismic with the missing traces as zeros) and **Press OK.**

8. In the "Input Data" window set the dimensions of the input features. To minimize processing time for this exercise, **Set** the Images dimension to: 0x128x128, overlap: 0x0x0 and Inline range: (100 – 400).

**Note:** If the current HW has large amount of GPU and CPU/computing power, the recommended Image Dimensions are 128x128x128.

9. **Specify** the name of the Output Deep Learning Example Data (e.g. ML\_Ex\_FillMissingTraces\_0x128x128 ) and **Press Proceed** to start the extraction process.

10. When this process is finished **Press Proceed** in the "Seismic Image Transformation" window to continue to the Training tab.

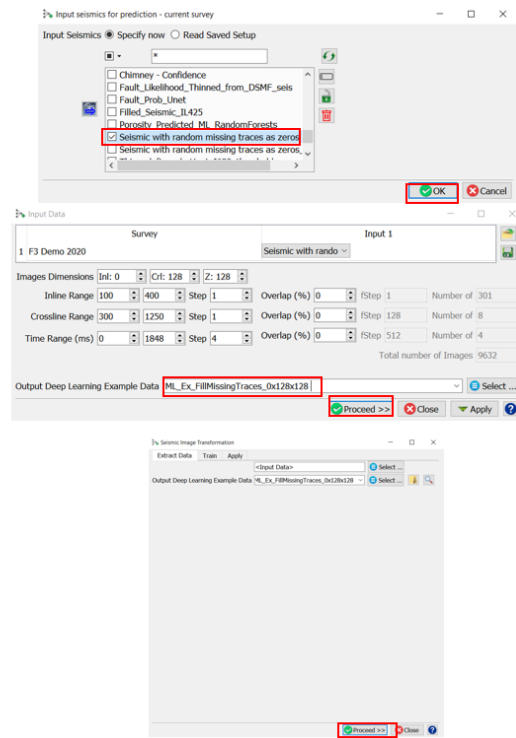

**Workflow cont'd:**

11. After the training data is selected the available models are shown. For seismic image workflows we use **Keras (TensorFlow)**.

12. **Check** the **Parameters** tab to see which models are supported and which parameters can be changed.

13. **Specify** a name for the "Output Deep Learning Model" (e.g. *ML\_Unet\_FillMissingTraces\_0x128x128*).

14. **Hit** Run.

15. **Open** the processing log file to follow the progress. When the log file shows "Finished batch processing", the Proceed button turns green. You can press **Proceed** or **Open** the **Apply** tab.

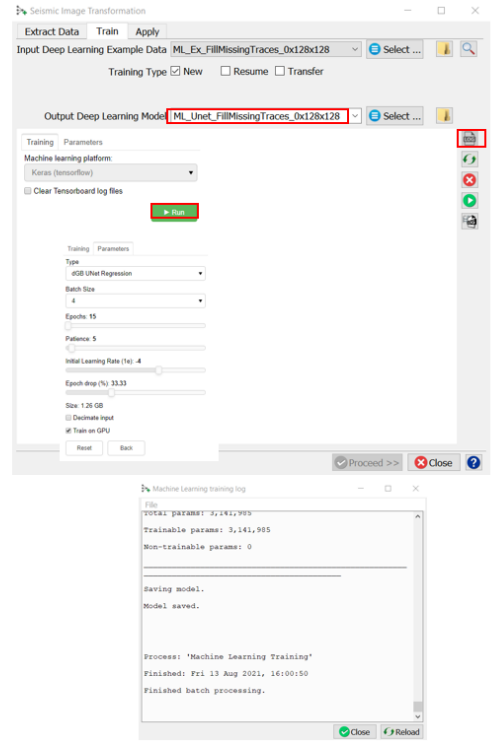

**Workflow cont'd:**

16. Once the Training is done, the trained model can be applied. **Select** the trained model and **Press Proceed**.

17. The **Apply** window **pops up**. Here you can optionally apply to a **Volume subsection**. **Type** an Output name (e.g. *Seismic\_ML\_Unet\_FillMissingTraces\_0x128x128*)

*Note: You can run on GPU or CPU using the **Predict using GPU** toggle. Running the application on a GPU is many times faster than running it on a CPU.*

18. **Press Run** to create the desired output.

19. **Close** the 'Progress Viewer' window when the processing is finished.

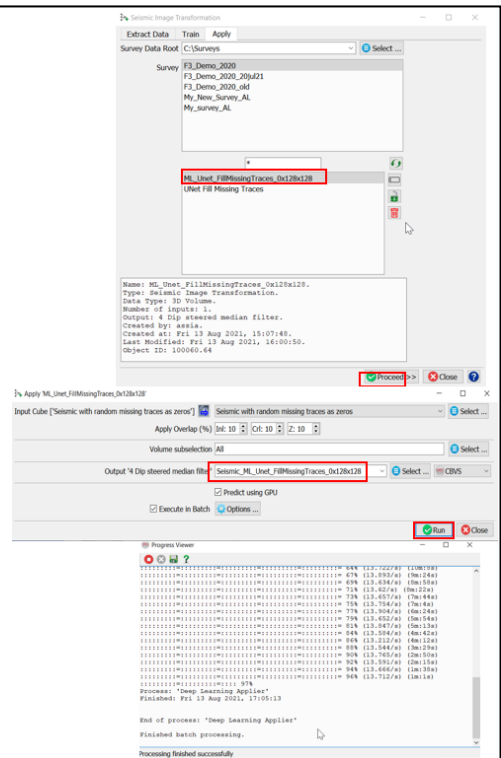

**Workflow cont'd:**

Compare the original seismic data with the Unet predicted filled seismic results. The line is extracted from the blind test area.

20. **Right Mouse Click** on In-line > Add and select Data > Store. **Select** the created Filled Seismic (e.g. ML\_Unet\_FillMissingTraces\_0x128x128), and **Hit** OK.

21. **Type** in the Inline field: 425, and **Hit** Enter.

The same way, add to the display, the original seismic and seismic with missing traces .

22. **Right-Click** on Inline 425 > Add > Attribute > Stored. **Select** the original seismic (e.g. 4 Dip steered median filter), and **Hit** OK.

23. **Right-Click** on Inline 425 > Add > Attribute > Stored. **Select** the seismic with missing traces (e.g. Seismic with random missing traces as zeros), and **Hit** OK.

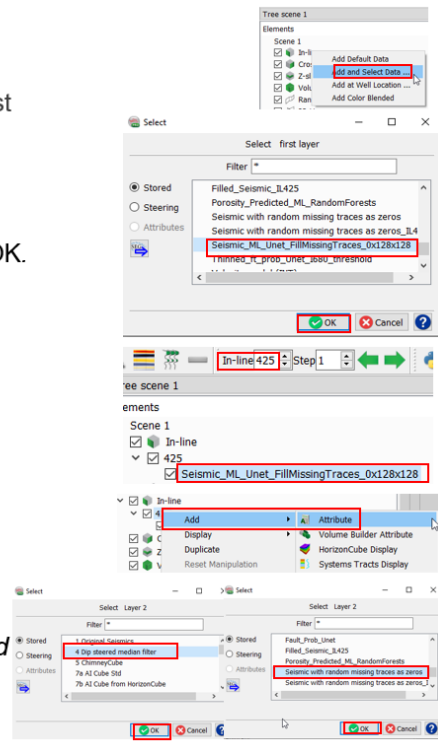

**Workflow cont'd:**

24. **Compare** visually in the blind test area the:

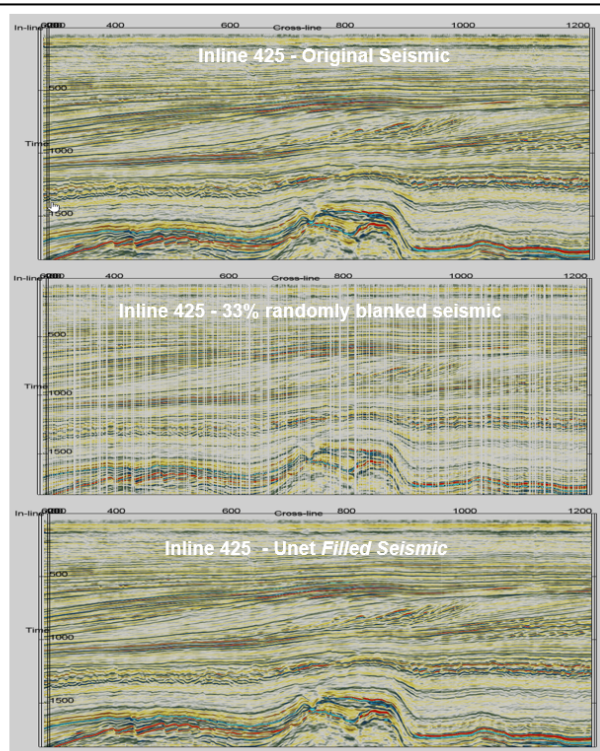

- Original seismic (4 Dip steered median filter)
- Randomly blanked traces seismic (Seismic with random missing traces as zeros)
- Unet filled seismic (ML\_Unet\_FillMissingTraces\_0x128x128)

25. For more accurate comparison, **Set** similar colour range for the 3 seismic cubes. Highlight the seismic cube, Set the colour bar range to (-8000, 8000).



### Workflow cont'd:

For a better quantitative comparison, create a new attribute 'difference' that computes the difference between the predicted and the original seismic.

**26. Select** the 3D attribute icon . **Open** the attribute set . **Select** the attribute set "ML\_Random\_holes\_interpolation"

**27. Create** a 4<sup>th</sup> attribute "difference" as indicated in the attribute set window and **Hit** 'Add as new'.

**28. Select** the Original seismic (e.g. *4 Dip steered median filter*) for 'Seis', and the predicted seismic (e.g. *ML\_Unet\_FillMissingTraces\_0x128x128*) for 'pred'

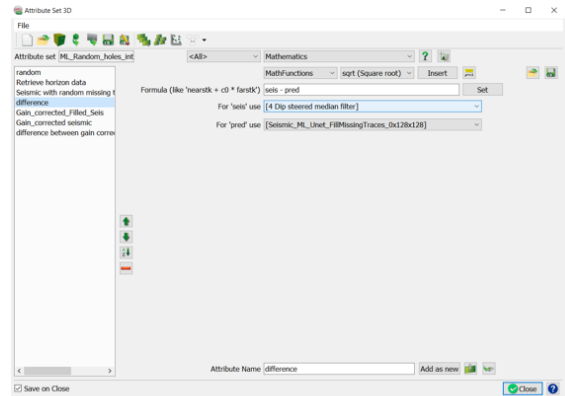

### Workflow cont'd:

Display/QC the attribute "difference". Difference = Original seismic (*4 Dip steered median filter*) – Predicted seismic (*ML\_Unet\_FillMissingTraces\_0x128x128*)

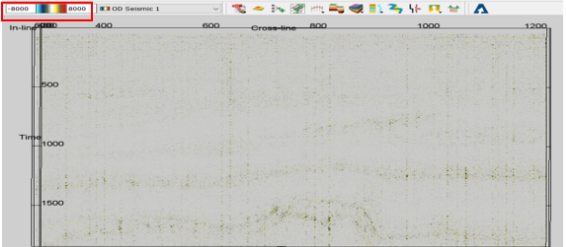
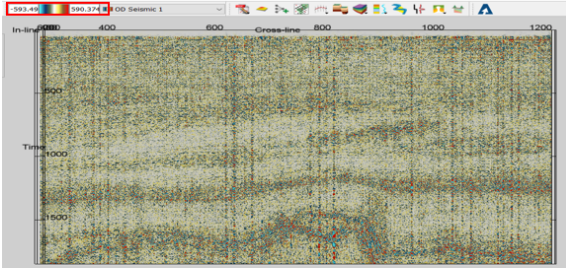
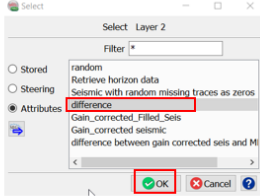

**29. Right-Click** on *Inline 425* > **Add** > **Attribute**. **Select** the attribute "difference", and **Hit** OK.



Notice the small values of the difference, range (-593, 590).

**30. For** more accurate comparison, **Modify** the color range to similar range as the original and predicted seismic [-8000,8000]

### Workflow cont'd (Optional):

For more accurate comparison, apply an RMS gain scaled correction to the original and predicted seismic, than compute the difference.

Create a new Gain correction attributes to be applied on the original and predicted seismic.

31. **Select** the 3D attribute icon . **Open** the attribute set . **Select** the attribute set "ML\_Random\_holes\_interpolation"

32. **Create** a 5<sup>th</sup> attribute "Gain\_corrected\_Filled\_Seis" as indicated in the attribute set window and **Hit** 'Add as new'

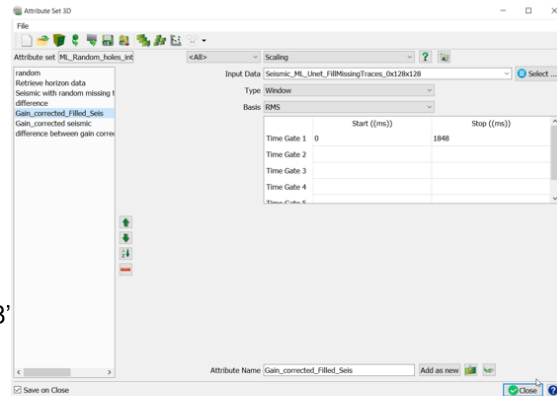

33. **Select** the Input Data "Seismic\_ML\_Unet\_FillMissingTraces\_0x128x128"



### Workflow cont'd (Optional):

For more accurate comparison, apply an RMS gain scaled correction to the original and predicted seismic, than compute the difference.

Create a new Gain correction attributes to be applied on the original and predicted seismic.

34. **Select** the 3D attribute icon . **Open** the attribute set . **Select** the attribute set "ML\_Random\_holes\_interpolation"

35. **Create** a 6<sup>th</sup> attribute "Gain\_corrected seismic" as indicated in the attribute set window and **Hit** 'Add as new'

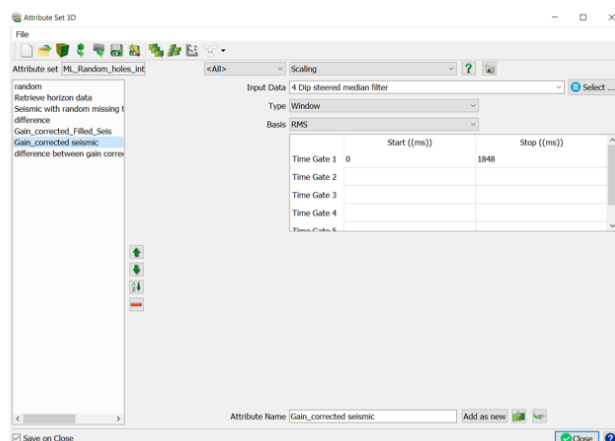

36. **Select** the Input Data 'Gain\_corrected seismic'





**Workflow cont'd (Optional):**

Create a new attribute that will compute the difference between the RMS gain corrected original seismic and ML predicted seismic

**37. Select** the 3D attribute icon  . **Open** the attribute set  . **Select** the attribute set "ML\_Random\_holes\_interpolation"

**38. Create** a 7<sup>th</sup> attribute "difference between gain corrected seis and ML pred" as indicated in the attribute set window and **Hit** 'Add as new'.

**39. Select** the "Gain\_corrected seismic" as input for 'seis' and the "Gain\_corrected\_Filled\_Seis" as input for 'pred'

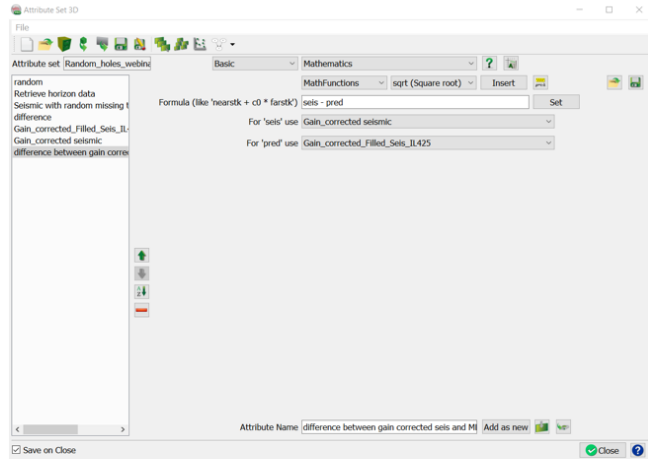

**Workflow cont'd (Optional):**

Display the attribute "Gain\_corrected\_Filled\_Seis" (RMS scaled Seismic\_ML\_Unet\_FillMissingTraces\_0x128x128) and the "Gain\_corrected seismic"(RMS scaled 4 Dip steered median filter).

**40. Right-Click** on Inline 425 > Add > Attribute. **Select** the attribute "Gain\_corrected\_Filled\_Seis", and **Hit** OK.

**41. Right-Click** on Inline 425 > Add > Attribute. **Select** the attribute "Gain\_corrected seismic", and **Hit** OK.

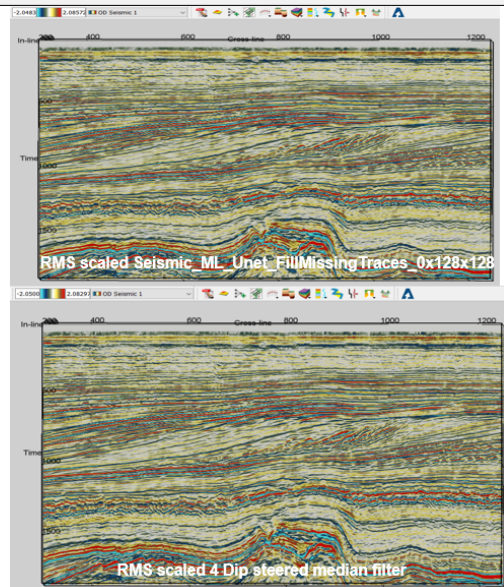

**Workflow cont'd (Optional):**

**Compare** quantitatively in the blind test area the RMS gain corrected difference between the *original seismic and the predicted seismic*.

42. **Display** the "difference between gain corrected seis and ML pred" seismic attribute. **Right mouse click** on the In-line 425. **Select** "Add and Select Data".

43. **Select** the attribute "difference between gain corrected seis and ML pred" and **Hit** Ok.

Notice the very low values of the "difference between gain corrected seis and ML pred". The range [-0.257, 0.257].

44. *For more accurate comparison, display the difference attribute with similar colour range as the gain corrected original and predicted seismic.* **Highlight** the seismic cube, Set the colour bar range to [-2, 2].

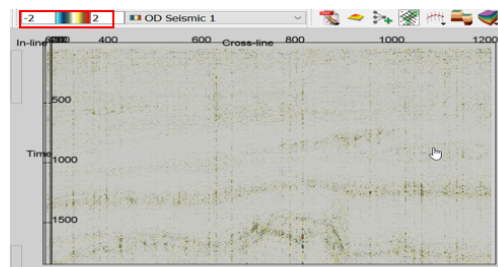
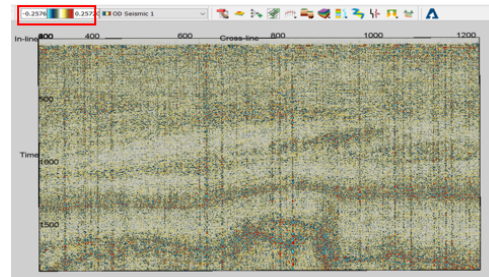

---

# Glossary

## A

---

### **Absolute Impedance**

Full-bandwidth impedance inversion response in which the "missing" low-frequency part of the spectrum has been added by the inversion method. For example - in model-driven inversions the low-frequency model is typically created by interpolating impedance well logs guided by mapped seismic horizons.

### **Accommodation Space**

The available space for sediments to fill (measured from seafloor to base-level).

## **AI**

Acoustic Impedance: the product of seismic velocity and density.

### **Attribute**

An attribute is a derived quantity from a seismic input set. Attributes in OpendTect are defined by a name, a value, and a position in 3D space (inline, cross-line and Z (2WT or depth)). Attributes can be calculated from single-trace, multi-trace, and multi-volume inputs. They can be steered and/or chained. Steered attributes are multi-trace attributes in which the trace segments are found by following a (pre-)calculated dip-azimuth. Chained attributes are attributes derived from other attributes. For example, Similarity and Energy are separate attributes that can be chained to calculate the Similarity of the Energy using the "Position" attribute.

### **Attribute Set**

An attribute set is an entity consisting of a group of attributes. Usually attributes in a defined attribute set have something in common. For example, all attributes in a set have the potential to highlight an object type of interest, or a combined attribute, using all other attributes as intermediate results. This would be a desirable output.

## **B**

---

### **Base level**

The surface at which sediment supply, relative sea level changes and wave energy are in balance. This is the surface at which the accommodation space equals zero: there is neither deposition, nor erosion.

---

## Body

A body is an element that defines an arbitrary three dimensional geological shape (or a geo-body). The body can also be created manually or by using polygons.

## C

---

### ChimneyCube

A volume that highlights vertical disturbances in seismic data. The cube is used in fluid migration path studies, in prospect ranking and for fault seal analysis. A ChimneyCube is generated by a neural network that was trained on picked examples (chimneys and non-chimneys). It gives at every sample location the "chimney probability" i.e. the likelihood of belonging to the class of identified seismic chimneys.

### Chrono-stratigraphy

A set of relative geologic time lines as stored in a HorizonCube.

### CLAS

A plugin for petrophysical analysis. CLAS stands for Computer Log Analysis System.

### Closed Source

Software that is released in binary form only. The commercial plugins to OpendTect are released as closed source extensions. Such extensions are only permitted if OpendTect is run under a commercial (or academic) license agreement.

### Color Blending

Combined display of three (four) attributes that are displayed in the Red Green and Blue color channels. Optionally the fourth channel (alpha) displays transparency. Color blending is aka as RGB (RGBA) blending.

### Crossline Dip

Dip in the direction of the Crossline axis, or in the direction of increasing crosslines.

## D

---

### Dip-Steering

The process of auto-tracking seismic data by following the pre-calculated, local dip and azimuth of the seismic. Dip-steering is used for: a) extracting seismic trace segments along seismic reflectors as input to multi-trace attribute calculations, b) computing special attributes such as polar dip, azimuth, and volume curvature attributes, c) filtering seismic data (known

---

as dip-steered filtering, aka structurally oriented filtering), and d) auto-tracking chrono-stratigraphic horizons in the creation of a HorizonCube.

### **Dip-Steering Cube**

A volume computed from seismic data with at every sample position information about the local dip and azimuth of the seismic data. In a 3D Steering Cube this information is stored in two attributes per sample: inline dip and cross-line dip. On 2D seismic only one value is stored: the line-dip. Dips in a Steering Cube are measured in the line direction and expressed in us/m or mm/m, for time and depth data, respectively.

---

## **E**

### **EEI**

Extended Elastic Impedance. Scaled and rotated impedance response at a particular angle. Rotation is typically optimized to predict a certain well log property of interest.

### **EI**

Elastic Impedance. Impedance response at a particular angle of incidence.

### **Element**

An element is a sub-division of various items (of the tree) that are displayed in a 3D scene. Inline, crossline, timeslices, horizon, wells etc are some elements. Each element is sub-divided into a sub-element. For instance an inline element can have further sub-elements e.g. inline # 120 that can contain upto eight different attributes.

### **Eustatic sea-level**

Sea-level relative to center of earth.

### **Explicit Representation**

A representation of a 3D object in OpendTect in the form of a triangulated surface.

---

## **F**

### **Fault Stickset**

The faults are interpreted on a section as a stick, and all sticks that belong to one fault are grouped in one sticksets. Therefore, a fault stickset contains an unordered collection of the interpreted sticks.

### **Forced regression**

Deposition characterized by progradation and incision. Base-level is falling decreasing accommodation space, forcing the system to prograde.

---

Forced regression occurs during the Falling stage systems tract.

## G

---

### **GMT**

An open source mapping package developed and maintained by the University of Hawaii (<http://gmt.soest.hawaii.edu/>). GMT stands for Generic Mapping Tools.

### **GPL License**

Gnu General Public License (<http://www.gnu.org/licenses/gpl.html>) is an open source license under which OpendTect can be run. The license allows redistribution of (modified) source code under the same licensing conditions (copy left principle). It is not allowed to combine the open source part with closed source plugins, which is why OpendTect is also licensed under a commercial license agreement and under an Academic license agreement.

## H

---

### **Horizon Data**

It refers to a stored attribute grid in a horizon. An attribute is calculated on-the-fly or in a batch process. On-the-fly, a user needs to store by right-clicking on it an selecting Save attribute... option. The saved attribute can also be managed in the Manage horizon. It may be noted that a horizon can contain unlimited stored attribute/horizon data.

### **HorizonCube**

A dense set of auto-tracked (or modeled) seismic horizons that is indexed and sorted according to relative geologic time (= chrono-stratigraphy).

## I

---

### **Implicit Representation**

A representation of a 3D object in OpendTect in the form of an iso-surface through a cube of values.

### **Incision**

Depositional feature caused by erosion.

### **Inline Dip**

Dip in the direction of the Inline axis, or in the direction of increasing inline numbers.

---

## M

---

### **Madagascar**

An open source seismic processing package. See: [http://en.wikipedia.org/wiki/Madagascar\\_\(software\)](http://en.wikipedia.org/wiki/Madagascar_(software))

### **Meta Attribute**

A meta-attribute is an attribute created from multiple input attributes. In OpendTect, a meta attribute is created either through neural networks, or through mathematical manipulations and/or logical operations. For example, TheChimneyCube and TheFaultCube are meta-attributes. See the Ridge enhancement filter attribute set from the Default attribute sets for an example of a meta-attribute created through math and logic. The meta-attribute in this set is the last attribute in the list.

### **MLP Neural Network**

Multi-Layer-Perceptron type of neural network. The network is used for seismic object detection (creating Chimney Cubes, Fault Cubes, Salt Cubes etc.) and for predicting rock properties from seismic data (Porosity, Vshale, Sw etc). An MLP network is trained on a data set with known examples (supervised learning). In the training phase the network aims to find the optimal, non-linear mapping between input attributes and target attributes. The network in OpendTect is a fully-connected, three-layer MLP (input layer, hidden layer, output layer). The non-linear transformation takes place in the hidden layer.

### **MPSI**

A plugin for stochastic acoustic impedance inversion. MPSI stands for Multi-Point Stochastic Inversion.

---

## N

---

### **Normal regression**

Deposition characterized by aggradation and progradation. The base level is rising but the consumption of accommodation space by sedimentation exceeds the creation of accommodation space by the base level rise. Normal regression occurs during high stand and low stand systems tracts.

---

## O

---

### **Open Source**

Software that is released with its source code. OpendTect is released as open source product that can be extended with closed source plugins.

---

Such extensions are only permitted if OpendTect is run under a commercial (or academic) license agreement.

## P

---

### PDF

PDF is Probability Density Functions. In OpendTect these are created in the cross-plot tool by selecting a desired area in the cross-plot domain. The density of the points in the selected area is a measure for the probability of the desired target variable that can then be predicted by applying the derived PDF function to (scaled) input volumes in a Bayesian classification scheme.

### Pickset

A Pickset is a collection of picked locations, i.e. inline-crossline-Z information. pointsets are part of a Pickset Group. For example a Pickset Group containing points at fault locations may consist of different fault pointsets to differentiate between large faults and small faults, or to reflect points on different inlines.

### Pickset Group

A Pickset group is a collection of different pointsets. Usually pointsets are grouped because they refer to the same object, e.g. Chimney\_yes or Chimney\_no.

## R

---

### Regression

Seaward shoreline & facies shift. Regression can be Normal (base level rises) or Forced (base level falls).

### Relative Impedance

Band-limited impedance inversion response computed by methods such as colored inversion.

### Relative sea-level

The net effect of eustatic sea level changes and local tectonic fluctuations.

### Retrogradation

Depositional trend characterized by sediments building landwards aka back-stepping.



---

## S

---

### **SEG-Y**

A file format for exchanging seismic or seismic-like data. It is used for both 2D and 3D pre- or post-stack data. A file being SEG-Y compliant does not mean that it can be loaded into OpendTect. There are several possible problems. One of these is missing trace identification and/or positioning. Another issue is lack of true compliance ->SEG-Y Rev 0, -> SEG-Y Rev 1). The different types of SEG-Y are shown below: \* SEG-Y Rev 0: The initial SEG-Y specification in 1975. It is very precise in some areas but totally unspecified in other, crucial areas. This has led to an almost uncountable number of variants. Some are sort-of SEG-Y standard, others blatantly non-compliant. \* SEG-Y Rev 1: In 2002 the Revision 1 document made an end to the most obvious shortcomings of ->SEG-Y Rev 0, especially in the area of ->trace positioning and ->trace identification. Still many SEG-Y files or files claimed to be SEG-Y are Rev 0 or badly (i.e. not) compliant with Rev 1. This is why OpendTect has numerous options for the SEG-Y reading process. \* SEG-Y Textual header: The first 3200 bytes of a SEG-Y file must be filled with textual comment on the contents of the SEG-Y file. Older textual headers are encoded in EBCDIC rather than ASCII, which makes them impossible to read in a standard text editor. \* SEG-Y EBCDIC header: -> SEG-Y Textual header. \* SEG-Y Tape Header: The part of a SEG-Y file that gives information about all traces in the file. This information is in the ->SEG-Y Textual header and ->SEG-Y Binary header. \* SEG-Y Binary header: The second part of the SEG-Y Tape header contains binary information about, amongst others, values for number of samples per trace, byte encoding, sample interval, and SEG-Y Revision. \* Trace identification: Every trace in OpendTect needs to have an identification in form of a trace number (2D data) or inline/crossline (3D data). For pre-stack data the offset forms and extra trace identification. \* Trace positioning: In OpendTect, every seismic trace needs to be located in 3D space. For 3D data, the position can be derived from the->Trace identification (inline- and crossline numbers). Traces in 2D lines have their own, separate X- and Y- coordinate. For pre-stack data there must also be an offset available.

### **SSIS**

A plugin to perform a sequence stratigraphic analysis (systems tracts, Wheeler transforms) from seismic data using HorizonCube input. SSIS stands for Sequence Stratigraphic Interpretation System.

### **Stratal Slicing**

The process of cutting through a seismic volume along surfaces that are computed proportionally between mapped top and bottom horizons, aka

---

proportional slicing.

## **Systems Tracts**

Subdivisions of sequences that consist of discrete depositional units that differ in geometry from other systems tracts and have distinct boundaries on seismic data. Different systems tracts are considered to represent different phases of baselevel changes.

## **T**

---

### **Trace Identification**

Every trace in OpendTect needs to have an identification in form of a trace number (2D data) or inline/crossline (3D data). For pre-stack data the offset forms and extra trace identification.

### **Trace Positioning**

In OpendTect, every seismic trace needs to be located in 3D space. For 3D data, the position can be derived from the->Trace identification (inline- and crossline numbers). Traces in 2D lines have their own, separate X- and Y- coordinate. For pre-stack data there must also be an offset available.

### **Transgression**

Landward shoreline & facies shift characterized by aggradation and retrogradation. The base-level is rising and more accommodation space is created than is consumed by sedimentation

### **Tree**

The tree is the docking window, which is detachable and movable. This is used to display the data into a scene. The tree is attached to a scene and is labeled as Tree Scene 1. Where '1' is the scene number. Each tree has its own elements that are displayed in corresponding scene.

## **U**

---

### **UVQ Neural Network**

Unsupervised Vector Quantizer type of neural network. This network is used for clustering (segmenting) data into a user-defined number of clusters. Cluster centers are found in a training run on a subset of the data. In the application phase the network generates two outputs: 1) the index number of the winning cluster and 2) the match, a value between 0 and 1 indicating how close the input vector is to the vector representing the winning cluster. UVQ segmentation can be performed in 2D mode (waveform segmentation along mapped horizons) and in 3D mode (gen-

---

erates 3D bodies). A display of the cluster centers is a useful diagnostic in waveform segmentation (Neural Network module: Info button).

## **V**

---

### **VMB**

A plugin for picking velocities from semblance gathers, and in a surface-consistent-manner. VMB stands for Velocity Model Building.

## **W**

---

### **Waveform Segmentation**

Process of clustering seismic trace segments with a UVQ network along a mapped horizon into a user-defined number of clusters.

### **WCP**

A plugin to pick and QC well log markers with the help of seismic data and (optionally) the HorizonCube. WCP stands for Well Correlation Panel.

### **Wheeler Transform**

Process of flattening seismic data (or attributes) according to the chrono-stratigraphic horizons in a HorizonCube. In a Wheeler scene the vertical axis represent relative geologic time.



---

# *Index*

2D Viewer 90

3D Auto-Track 81

3D Bodies From HorizonCube 215

Attributes - Attributes 164

Attributes - Wells 173

Basemap 36

Batch 122

Bodies 176

Bright Spot 125

ChimneyCube 193

Coloured Inversion 260

Data-Driven HorizonCube 200

Dip 39, 42, 45, 49, 107, 142, 144, 150, 155, 193, 200

Dip-Steered Diffusion Filter 45

Dip-Steered Fault Enhancement Filter 49

Dip-Steered Median Filter 42

Dip-Steered Similarity 144

Dip & Azimuth 142

Display 27

Display An Inline 27

Extracting Horizontal Variograms 266

Extracting Vertical Variograms 269

---

Fault 49, 95, 98, 153, 303, 312

Fault Planes 95

Fault Sticks 98

Filter 42, 45, 49, 55

Fluid Contact Finder 71

Grid 115

Grid Stacking Velocities 115

Help 1

Horizon 14

HorizonCube 110, 160, 200, 215, 220, 223, 251

Horizons From HorizonCube 223

How-To Instructions 1

Import 23

Import data from Petrel using PetrelDirect 23

Lithology Classification 290

Log 279-280, 285

Log-Log Density 280

Log-Log Porosity 285

Mathematics 148

Neural Network 271

Neural Network Prediction 271

Optical Stacking 64

PDF3D 38

Planes 180

---

Position, Zoom, Pan, Rotate 29

Pre-load 28

Pre-Load Data 28

Random Line 33, 35

Random Line Through Wells 35

Ridge Enhancement Filter 55

Scene 230

SEG-Y 4

Seismic and Wells RockProperty Prediction 307

Seismic Bodies Supervised 3D 297

Seismic Feature Enhancement 67

Seismic Image Regression Unet Fill Seismic Traces 319

Seismic Image to Image - Fault Prediction 312

Seismic Unet 3D Fault Predictor 303

Set up Survey usingPetrelDirect 12

Setup 4

Spectral Blueing 58

Spectral Decomposition 136

SSIS 225, 230, 235, 242, 245, 255

Stacking Patterns 227

Stacking Velocities 21

Statistical Curves 242

Steering 39, 107, 150

Stratal Slicing 255

---

Stratal Terminations 225

Stratigraphic Attributes 160, 251

Stratigraphic Surfaces 245

Survey 4, 12

Survey Setup & Load SEG-Y 4

Systems Tracts 235

Table 2

Table Of Contents 2

TD Conversion On-The-Fly 119

TD Volume Conversion In Batch 122

Thalweg Tracker 103

Thinned Fault Likelihood 153

Tracking 90, 200

Tracking In 2D Viewer 90

Truncate HorizonCube 220

Unconformity Tracker 107, 150

UVQ 184, 187

Volume 122, 155

Volume Curvature And Others 155

Waveform Segmentation - Quick UVQ 184

Waveform Segmentation - Standard UVQ 187

Well 16, 75, 110, 279

Well Correlation Panel 110

Well Data 16

---



---

Well Tie 75

Wells 35, 173, 307

Wheeler Scene 230

